



MT3200

TRAVELING WAVE TUBE MEDIUM POWER AMPLIFIER

FOR SATELLITE UPLINK APPLICATIONS

C-BAND: 400W
X-BAND: 400W
Ku-BAND: 400W



AVAILABLE SYSTEM OPTIONS:

MT3211 1 + 1 Redundant System

MT3212 1 + 2 Redundant System

MT32PC Phase Combined, Single Path Redundant System

MT32PC2 Phase Combined, Dual Path Redundant System

Other Configurations Available Upon Request

AVAILABLE AMPLIFIER OPTIONS:

Controller Bypass

Parallel Remote Interface

Manual Attenuator

Internal Linearizer

Extended Band Operations

SLIM/R Remote Panel

FEATURES:

Field Replaceable Modules For Unsurpassed Serviceability

Closed-Loop Forced Air Cooling

Typical Phase Noise 12 dB Below IESS-308

Control Dial For Easy Set-Up And Adjustment



Redundant Configurations Available Including Phase Combined, Dual Path

ISO 9001



501 S. Woodcreek Road, Bolingbrook, IL U.S.A., 60440-4999 • 630-759-9500 FAX: 630-759-5018

MT3200

TRAVELING WAVE TUBE MEDIUM POWER AMPLIFIER

ELECTRICAL SPECIFICATIONS	C-BAND	X-BAND	Ku-BAND
	400 W	400 W	400 W
Frequency Range (F ₀) (Standard): (Extended):	5.850 - 6.650 GHz Option: 5.850 - 7.025 GHz	7.9 - 8.4 GHz	13.75 - 14.50 GHz Option: 12.75 - 14.50 GHz
Output Power (min.): Tube Output Flange: HPA Output Flange:	400 W (56.0 dBm) 360 W (55.5 dBm)	400 W (56.0 dBm) 360 W (55.5 dBm)	400 W (56.0 dBm) 360 W (55.5 dBm)
Gain:			
At Rated Power (min.):	73 dB	77 dB	73 dB
Small Signal Gain (SSG) (min.):	77 dB	81 dB	77 dB
Attenuation Range:		32 dB (0.1 Inc.)	
Maximum SSG Variation Over:			
Narrow Band:	1.0 dB/40 MHz		1.0 dB/80 MHz
Per 500 MHz:		2.5 dB	
Slope, Max.:	±0.03 dB/MHz		±0.04 dB/MHz
Gain Stability:		±0.25 dB/24 hr. max. (constant drive, line voltage and temp.)	
Stability, Any Freq. Over Entire Temp.:		±1 dB typ.	
Stability, Any Freq. ±10°C:		±0.75 dB max.	
Input VSWR:		1.20:1 max. with respect to 50 Ohms	
Output VSWR:		1.60:1 max. with respect to 50 Ohms	
Load VSWR:		2.0:1 max. without damage, continuous	
AM/PM Conversion:			
At Rated Power:		6.0°/dB	
6 dB Below Rated Power:		2.5°/dB	
Residual AM Noise, Max.:			
Below 10 kHz:		-50 dBc	
10 - 500 kHz:		-20 (1.5 + Log _f kHz) dBc	
Above 500 kHz:		-85 dBc	
Harmonic Output, Max.:		-60 dBc	
Noise & Spurious, Max.:			
Receive Band (Standard):	-130 dBW/4 kHz, 3.4 - 4.2 GHz	-130 dBW/4 kHz, 7.25 - 7.75 GHz	-130 dBW/4 kHz, 10.7 - 12.75 GHz
(Extended):	-130 dBW/4 kHz, 3.4 - 4.2 GHz	N/A	-130 dBW/4 kHz, 10.7 - 11.7 GHz
Transmit Band (F ₀):	-65 dBW/4 kHz	-65 dBW/4 kHz	-65 dBW/4 kHz
Phase Noise:		10 dB below IESS Phase Noise Profile	
AC Fundamental:		-50 dBc	
Sum Of All Except AC Fundamental:		-47 dBc	
Intermodulation (for 2 equal carriers relative to single carrier rated output):		Total P ₀	IM Product
Linearizer Option:		-4 dBc	-18 dBc
		-7 dBc	-24 dBc
		-4 dBc	-27 dBc
Group Delay:	Any 40 MHz Bandwidth		Any 80 MHz Bandwidth
Linear:	0.01 ns/MHz		0.01 ns/MHz
Parabolic:	0.001 ns/MHz ²		0.005 ns/MHz ²
Ripple:	0.5 ns p-p		0.5 ns p-p
Prime Power:			
Voltage:		100 - 264 VAC, 1-phase, 47 - 63 Hz	
Power Consumption (at Rated RF Out):		1.5 KVA typ.	
Power Factor:		0.95 min.	
In-Rush:		30A max.	
Input Transients:		EN61000-4-4, 4-5, 4-11 (Surge, Fast Transients, Line Dropout)	

Note: Performance information is subject to change without notification. Contact MCL for the latest specifications.

RF BLOCK DIAGRAM

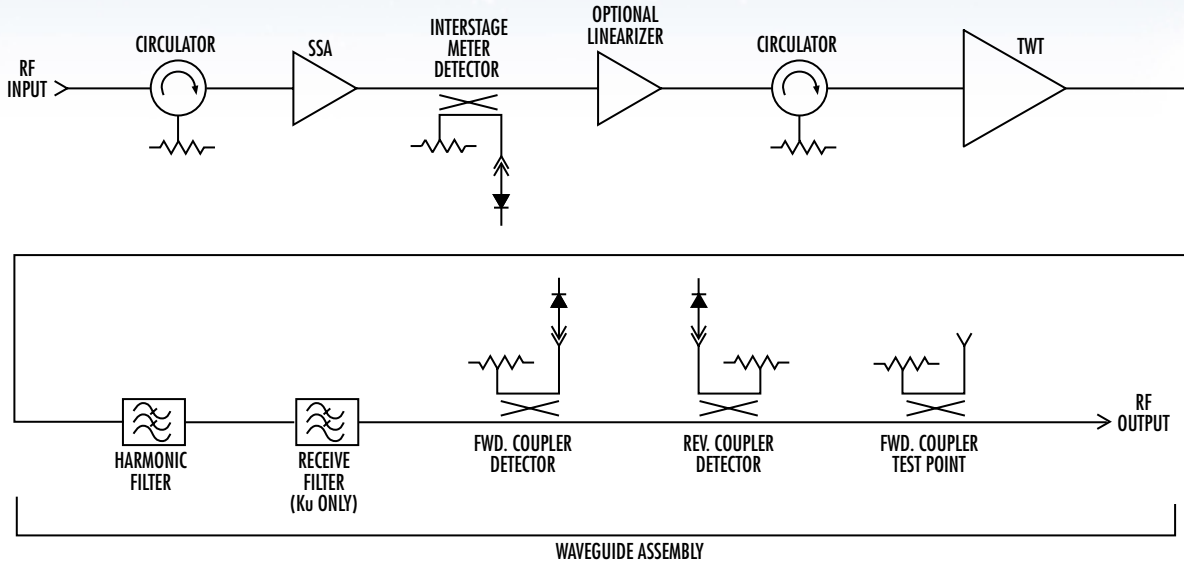

CONTROL AND STATUS CAPABILITIES

TYPE	FUNCTION	
Local Controls	Power On RF ON/OFF Local/Remote/Computer Attenuation (Gain)	Transmit/Standby Reset Switchover
Displays	Tube Drive Power RF Forward Power Helix Voltage Filament Delay	Forward Power Sample Port RF Reflected Power Helix Current
Adjustable Parameters	RF High Alarm	RF Low Alarm
Alarms (Notification Only)	RF High	RF Low
Faults (Notification, RF & HV Shutdown)	Summary RF Reflected Power Tube Temperature Helix Surge Current HV Under Voltage Power Supply Temperature	Tube Overdrive Chassis Interlock User Interlock Helix Run Current HV Over Voltage External Interlock

MT3200

OUTLINE DRAWING

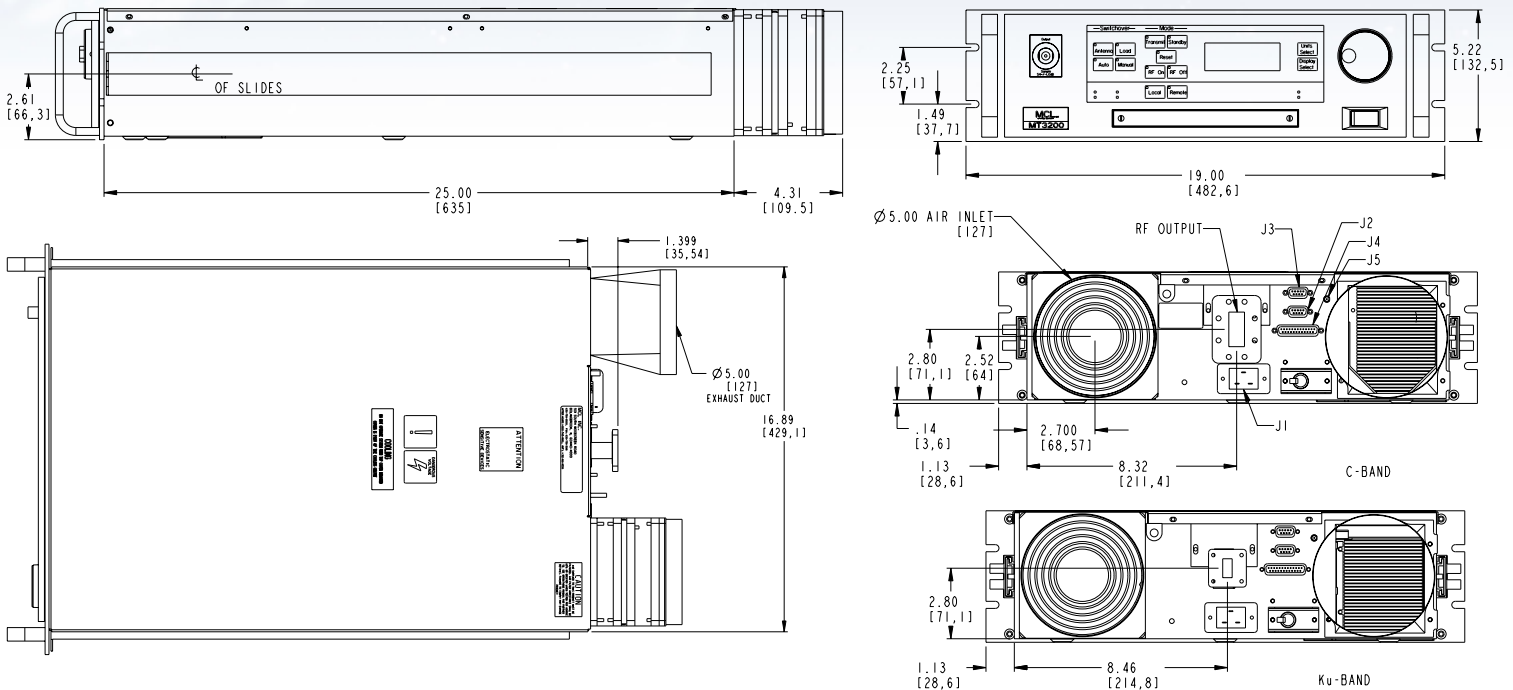

ENVIRONMENTAL SPECIFICATIONS

Operating Temperature:

-10°C to +50°C (derated 1.9°C per 1,000 ft. above sea level)

Non-Operating Temperature:

-20°C to +70°C

Relative Humidity:

95%, non-condensing

Operating Altitude:

10,000 ft. above sea level (3,048 m)

Non-Operating Altitude:

50,000 ft. above sea level (15,240 m)

Vibration:

Meets the vibratory extremes specified in MIL-STD-810, Method 514.3, Procedure 1

Shock:

Meets performance specifications after 15g for 11ms shock specified in MIL-STD-810, Method 516.4, Procedure VI

Maximum Backpressure:

0.5 inches of water (exhaust air)

CONNECTOR CHART

DSGN	DESCRIPTION	CONNECTOR
J1	AC INPUT	3P, AC, IEC 320 C-20
J2	COMPUTER/REMOTE INTERFACE	"D" CONN. 9 PIN
J3	USER INTERFACE	"D" CONN. 9 PIN
J4	SWITCHOVER INTERFACE	"D" CONN. 25 PIN
J5	RF INPUT	SMA FEMALE
J6	RF OUTPUT	CPG137 (C-BAND) WR75 (Ku-BAND)

MECHANICAL SPECIFICATIONS

RF Connectors:

Input: Type SMA female
Output: (Waveguide Flange)
C-Band: CPR137F
X-Band: WR112F
Ku-Band: WR75F

Installed Weight:

78 lbs. maximum

Cooling:

Closed-loop forced air with integral blower

Acoustic Noise:

<65 dBA at 1 meter (from front panel)

PHYSICAL SPECIFICATIONS

Dimensions:

5.25" H (3RU)
19.00" W
25.00" L (nominal)

Air Flow:

110 CFM

MCL, INC
501 S. Woodcreek Road, Bolingbrook, IL U.S.A., 60440-4999 • 630-759-9500 FAX: 630-759-5018
24-HOUR CUSTOMER SUPPORT NUMBER IN THE USA: 1-800-743-4625
OUTSIDE THE USA: 312-461-4536 • www.mcl.com



MT3200-02.03