

**HP 8340B
SYNTHESIZED SWEEPER
(Including Options 001, 004,
005, 006, and 007)**

**HP 8341B
SYNTHESIZED SWEEPER
(Including Options 003, 004)**

SERIAL NUMBERS

This manual applies directly to the HP 8340B Synthesized Sweeper having a serial number prefix of 2624A and the HP 8341B Synthesized Sweeper prefixed 2624A.

For additional information about serial numbers, refer to INSTRUMENTS COVERED BY THE MANUAL in Section I.

©Copyright HEWLETT-PACKARD COMPANY 1986
1400 FOUNTAINGROVE PARKWAY, SANTA ROSA, CA 95401 U.S.A.

MANUAL PART NO. 08340-90243
Microfiche Part Number 08340-90244

Printed: AUGUST 1986



CERTIFICATION

Hewlett-Packard Company certifies that this product met its published specifications at the time of shipment from the factory. Hewlett-Packard further certifies that its calibration measurements are traceable to the United States National Bureau of Standards, to the extent allowed by the Bureau's calibration facility, and to the calibration facilities of other International Standards Organization members.

WARRANTY

This Hewlett-Packard instrument product is warranted against defects in material and workmanship for a period of one year from date of delivery, or, in the case of certain major components listed in section six of this Operating and Service manual, for the specified period. During the warranty period, Hewlett-Packard Company will, at its option, either repair or replace products which prove to be defective.

For warranty service or repair, this product must be returned to a service facility designated by HP. Buyer shall prepay shipping charges to HP and HP shall pay shipping charges to return the product to Buyer. However, Buyer shall pay all shipping charges, duties, and taxes for products returned to HP from another country.

LIMITATION OF WARRANTY

The foregoing warranty shall not apply to defects resulting from improper or inadequate maintenance by Buyer, Buyer-supplied software or interfacing, unauthorized modification or misuse, operation outside of the environmental specifications for the product, or improper site preparation or maintenance.

NO OTHER WARRANTY IS EXPRESSED OR IMPLIED. HP SPECIFICALLY DISCLAIMS THE IMPLIED WARRANTIES OF MERCHANTABILITY AND FITNESS FOR A PARTICULAR PURPOSE.

EXCLUSIVE REMEDIES

THE REMEDIES PROVIDED HEREIN ARE BUYER'S SOLE AND EXCLUSIVE REMEDIES. HP SHALL NOT BE LIABLE FOR ANY DIRECT, INDIRECT, SPECIAL, INCIDENTAL, OR CONSEQUENTIAL DAMAGES, WHETHER BASED ON CONTRACT, TORT, OR ANY OTHER LEGAL THEORY

ASSISTANCE

Product maintenance agreements and other customer assistance agreements are available for Hewlett-Packard products.

For any assistance, contact your nearest Hewlett-Packard Sales and Service Office. Addresses are provided at the back of this manual.

Table 1-1. Model HP 8340B Specifications and Supplemental Performance Characteristics (1 of 15)

NOTE

Specifications are the performance standards, or limits, against which the instrument may be tested. The following Specifications apply for temperatures between 0 and +50°C except where noted. Specifications apply with the PEAK function ON in the CW and MANUAL modes of operation, and with periodic use of AUTO TRACKING CALIBRATION in swept operation.

Supplemental Performance Characteristics are in *italics* in this table and are intended to provide information useful in applying the instrument by giving typical, but non-warranted, performance parameters. These are denoted as "typical," "nominal," or "approximate."

FREQUENCY

CW MODE

Range: 0.01 to 26.5 GHz

Resolution: $n \times 1$ Hz

Where N = harmonic multiplication (1 to 4). Refer to Frequency ranges and Bandswitch Points description below.

Accuracy: Same as Time Base Accuracy

Time Base

Frequency: 10 MHz

Aging Rate:

1×10^{-9} per day, 2.5×10^{-7} per year after 72 hour warm up if HP 8340B has been disconnected from ac power for less than 24 hours. Aging rate is achieved after 7 to 30 days warm up if HP 8340B has been disconnected from ac power for greater than 24 hours.

Temperature Coefficient: *Typically* $< 1 \times 10^{-10}$ per °C

Change due to 10% line voltage change: *Typically* $< 1 \times 10^{-11}$

Accuracy:

Overall accuracy of internal time base is a function of time base calibration \pm aging rate \pm temperature effects \pm line effects.

Switching Time: <50 msec (PEAK function off)

Fast Phase Lock Mode reduces typical switching time to <20 msec.)

CENTER FREQUENCY/SWEEP WIDTH MODE (CF/ Δ F)

Range: 10.00005 MHz to 26.49999995 GHz (**center frequency**)

100 Hz to 26.49 GHz (**sweep width**)

Resolution: *Approximately 0.1% of sweep width (Δ F)*

Readout Accuracy with respect to sweep out voltage (sweep time > 100 msec):

$\Delta \leq n \times 5$ MHz: $\pm 1\%$ of indicated sweep width (Δ F) \pm time base accuracy*

$\Delta > n \times 5$ MHz to < 300 MHz: $\pm 2\%$ of indicated sweep width (Δ F)

$\Delta \geq 300$ MHz: $\pm 1\%$ of indicated sweep width (Δ F), or ± 50 MHz, whichever is less

Where n = harmonic multiplication number (1 to 4). Refer to Frequency Ranges and Bandswitch Points description below.

*Time Base effects Center Frequency accuracy only, not sweep width accuracy.

Supplemental Performance Characteristics are in *italics*.

Table 1-1. Model HP 8340B Specifications and Supplemental Performance Characteristics (2 of 15)

FREQUENCY (Cont'd)

START/STOP MODE

Range

Start: 10 MHz to 26 499 9999 MHz

Stop: 10.0001 MHz to 26.5 GHz

Resolution: *Typically, the same as Center Frequency/Sweep Width mode.*

Readout Accuracy with respect to sweep out voltage (sweep time > 100 msec):
Same as Center Frequency/Sweep Width Mode

FREQUENCY MARKERS

All 5 markers are independently variable and have the same specifications.

Range: 10 MHz to 26.5 GHz

Resolution: *Approximately 0.1% of sweep width (ΔF)*

Readout Accuracy (sweep time > 100 msec):
Same as **CENTER FREQUENCY/SWEEP WIDTH MODE (CF/ ΔF)**.

*Time base accuracy is not a factor in MKR Δ Mode.

FREQUENCY RANGES AND BANDSWITCH POINTS

For bands 0 and 1, the HP 8340B's output is derived from the fundamental frequency of its internal 2.3 to 7.0 GHz YIG-tuned oscillator ($n=1$). For bands 2, 3, and 4 the output is derived from the 2nd, 3rd, or 4th harmonic of the oscillator ($n = 2, 3, \text{ or } 4$)

Bandswitch points in CW Mode (only) always occur at the following points.

- Band 0 to 1: 2.3 GHz
- Band 1 to 2: 7.0 GHz
- Band 2 to 3: 13.5 GHz
- Band 3 to 4: 20.0 GHz

Bandswitch points in each of the swept modes (CF/ ΔF , START/STOP) and the MANUAL SWEEP mode normally occur at the following points (with the exception listed below):

- Band 0 to 1: 2.4 GHz
- Band 1 to 2: 7.0 GHz
- Band 2 to 3: 13.5 GHz
- Band 3 to 4: 20.0 GHz

The swept mode bandswitch points are illustrated in Figure 1.

Supplemental Performance Characteristics are in *italics*.

Table 1-1. Model HP 8340B Specifications and Supplemental Performance Characteristics (3 of 15)

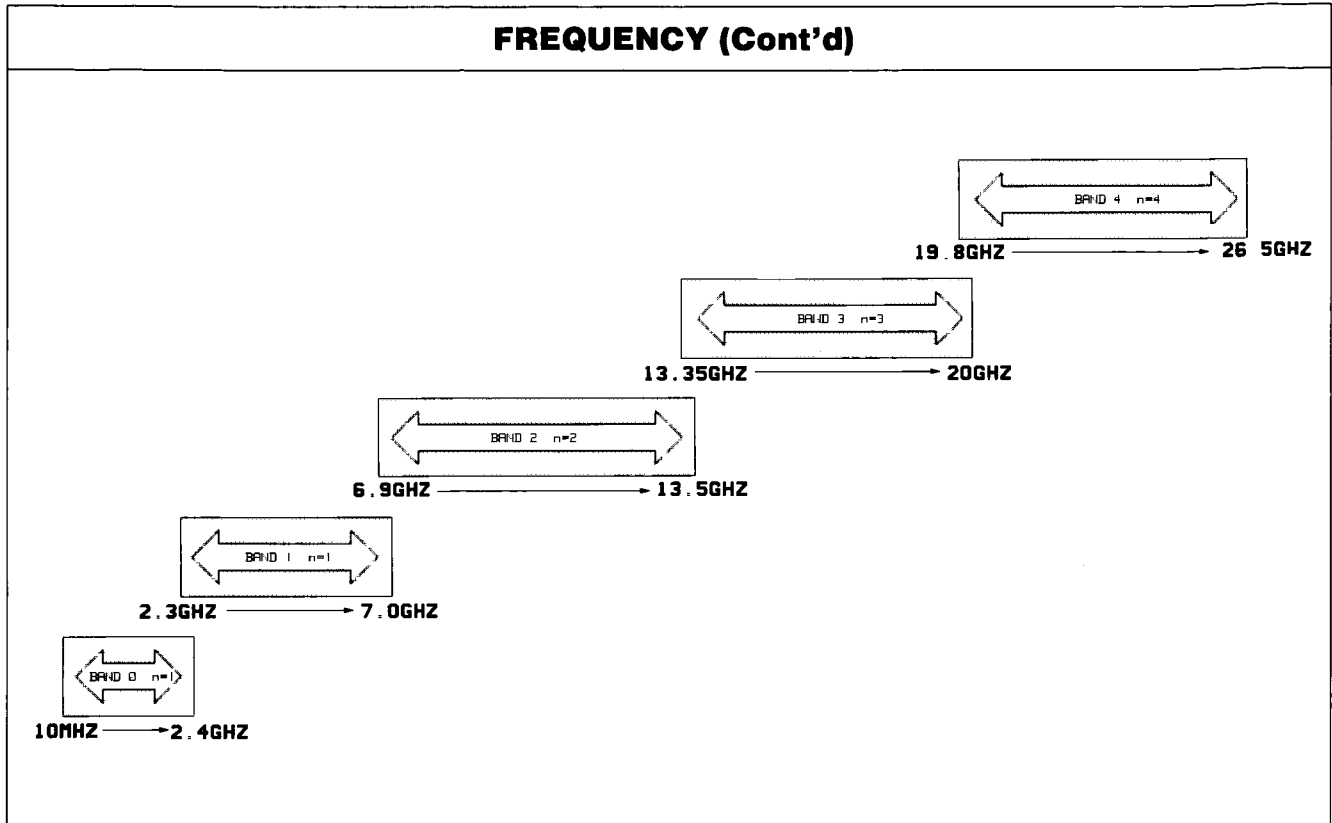

Figure 1. Typical Frequency Ranges and Bandswitch Points in Swept Modes

Note that the bands overlap. However, any sweep will be executed with the minimum number of bandswitch points. If the start frequency is above the lower limit for a given band, the sweep will start in that band and not the next lower one. If the stop frequency exceeds the upper limit of a given band by an amount greater than $0.004 \times \Delta F$, a bandswitch will occur at that band's upper limit.

SPECTRAL PURITY

(Spectral Purity specifications apply for CW mode and all swept modes, unless otherwise stated.)

SPURIOUS SIGNALS (Expressed in dB relative to the carrier level (dBc) at ALC level of 0 dBm)	Bands and Approximate Frequency Ranges (GHz) (See Frequency Ranges and Bandswitch Points for complete description)				
	Band 0 0.01 to <2.3	Band 1 2.3 to <7.0	Band 2 7.0 to <13.5	Band 3 13.5 to <20.0	Band 4 20.0 to 26.5
Harmonics (only up to 26.5 GHz)	< -35	< -35	< -35	< -35	< -35
Subharmonics and multiples thereof (up to 26.5 GHz)	—	—	< -25	< -25	< -20
Non-harmonically related spurious (CW and Manual Sweep mode only)	< -50	< -70	< -64	< -60	< -58

Supplemental Performance Characteristics are in *italics*.

Table 1-1. Model HP 8340B Specifications and Supplemental Performance Characteristics (4 of 15)

SPECTRAL PURITY (Cont'd)

SPURIOUS SIGNALS (Cont'd)

Power line related and spurious due to fan rotation within 5 Hz below line frequency, and multiples thereof

(CW mode only, all power levels)	Band 0 0.01 to <2.3	Band 1 2.3 to <7.0	Band 2 7.0 to <13.5	Band 3 13.5 to <20.0	Band 4 20.0 to 26.5
Offset <300 Hz from carrier	< -50	< -50	< -44	< -40	< -38
Offset 300 Hz to 1 kHz from carrier	< -60	< -60	< -54	< -50	< -48
Offset >1 kHz from carrier	< -65	< -65	< -59	< -55	< -53

SINGLE-SIDEBAND PHASE NOISE (dBc/1 Hz BW, CW Mode, all power levels)

STANDARD INSTRUMENT

Offset 30 Hz from carrier	< -64	< -64	< -58	< -54	< -52
Offset 100 Hz from carrier	< -70	< -70	< -64	< -60	< -58
Offset 1 kHz from carrier	< -78	< -78	< -72	< -68	< -66
Offset 10 kHz from carrier	< -86	< -86	< -80	< -76	< -74
Offset 100 kHz from carrier	< -107	< -107	< -101	< -97	< -95

OPTION 007, Relaxed Phase Noise Specifications

Offset 100 Hz from carrier	< -67	< -67	< -61	< -57	< -55
Offset 1 kHz from carrier	< -75	< -75	< -69	< -65	< -63
Offset 10 kHz from carrier	< -83	< -83	< -77	< -73	< -71
Offset 100 kHz from carrier	< -107	< -107	< -101	< -97	< -95

TYPICAL FREQUENCY STABILITY, 50 Hz - 15 kHz post detection bandwidth

Typical Residual FM in CW Mode: $< n \times 60 \text{ Hz rms}$

Typical Residual FM in Swept Mode.

$\Delta F > n \times 5 \text{ MHz: } < n \times 25 \text{ kHz rms}$

$\Delta F \leq n \times 5 \text{ MHz: Same as CW mode}$

Where n = harmonic multiplication number (1 to 4). Refer to Frequency Ranges and Bandswitch Points description above

Supplemental Performance Characteristics are in *italics*.

Table 1-1. Model HP 8340B Specifications and Supplemental Performance Characteristics (6 of 15)

RF OUTPUT (Cont'd)			
OUTPUT POWER ACCURACY (Cont'd)	Band 0 0.01 to <2.3	Bands 1-3 2.3 to <20.0	Band 4 20.0 to 26.5
OPTION 001 (Front Panel Output w/o Attenuator) +18 to +10 dBm ³ +10 to -10 dBm -10 to -20 dBm	— ±0.9 dB ±1.7 dB	±1.6 dB ±1.3 dB ±2.1 dB	±2.0 dB ±1.7 dB ±2.5 dB
OPTION 005 (Rear Panel Output w/o Attenuator) +18 to +10 dBm ³ +10 to -10 dBm -10 to -20 dBm	— ±1.0 dB ±1.8 dB	±1.8 dB ±1.5 dB ±2.3 dB	±2.2 dB ±1.9 dB ±2.7 dB
FLATNESS (Internally leveled)			
STANDARD INSTRUMENT +18 to +10 dBm ³ +10 to -9.95 dBm -10 to -19.95 dBm -20 to -49.95 dBm -50 to -79.95 dBm -80 to -100 dBm -100 to -110 dBm (typical)	— ±0.6 dB ±0.9 dB ±1.2 dB ±1.4 dB ±1.7 dB ±1.9 dB	±1.2 dB ±1.1 dB ±1.6 dB ±1.9 dB ±2.2 dB ±2.5 dB ±3.1 dB	±1.7 dB ±1.6 dB ±2.1 dB ±2.4 dB ±2.7 dB ±3.0 dB ±3.6 dB
OPTION 004 (Rear Panel Output w/Attenuator) +18 to +10 dBm ³ +10 to -11.95 dBm -12 to -21.95 dBm -22 to -51.95 dBm -52 to -81.95 dBm -82 to -100 dBm -100 to -110 dBm (typical)	— ±0.7 dB ±1.0 dB ±1.3 dB ±1.5 dB ±1.8 dB ±2.0 dB	±1.4 dB ±1.3 dB ±1.8 dB ±2.1 dB ±2.4 dB ±2.7 dB ±3.3 dB	±1.9 dB ±1.8 dB ±2.3 dB ±2.6 dB ±2.9 dB ±3.2 dB ±3.8 dB
OPTION 001 (Front Panel Output w/o Attenuator) +18 to +10 dBm ³ +10 to -10 dBm -10 to -20 dBm	— ±0.6 dB ±0.8 dB	±1.0 dB ±0.9 dB ±1.5 dB	±1.4 dB ±1.3 dB ±1.9 dB
OPTION 005 (Rear Panel Output w/o Attenuator) +18 to +10 dBm ³ +10 to -10 dBm -10 to -20 dBm	— ±0.7 dB ±0.9 dB	±1.2 dB ±1.1 dB ±1.7 dB	±1.6 dB ±1.5 dB ±2.1 dB

Supplemental Performance Characteristics are in *italics*.

Table 1-1. Model HP 8340B Specifications and Supplemental Performance Characteristics (7 of 15)

RF OUTPUT (Cont'd)	
<p>TYPICAL ALC INCREMENTAL ACCURACY</p> <p style="text-align: center;"><i>Figure 2. Typical ALC Incremental Accuracy</i></p> <p>In normal operation, the ALC does not operate below -9.95 dBm because the 8340B automatically increments the step attenuator at that point. However, when the ALC and step attenuator are independently controlled (DECOUPLED mode), the ALC may be operated over its full $+20$ dBm to -20 dBm range. Refer to Section III. Operation for a more detailed description. Pressing [SHIFT] [PWR SWP] places the instrument in the decoupled mode. In this mode the data entry keyboard and the rotary knob control the ALC level, and the step up and step down keys control the attenuator.</p>	
<p>RF OUTPUT CONNECTOR</p> <p>Output Impedance: <i>Nominally 50 Ohms</i></p> <p>Typical Source SWR (Internally leveled only). <i>0.1 to <2.3 GHz: Typically <1.3:1</i> <i>2.3 to <18.0 GHz: Typically <1.6:1</i> <i>18.0 to 26.5 GHz: Typically <2.0:1</i></p>	
<p>STABILITY WITH TEMPERATURE: <i>Typically ± 0.01 dB/°C</i></p>	
<p>OUTPUT LEVEL SWITCHING TIME: <i>Typically <10 ms to be within 0.1 dB of final value with no attenuator range change (internally leveled only).</i></p>	
<p>POWER SWEEP</p> <p>Range: Displayed: 0 to 40 dB/sweep Actual: At least 10 dB at any given frequency (at least 20 dB in DECOUPLED mode. see Figure 3 below).</p> <p>Resolution: 0.05 dB/sweep</p> <p>Accuracy: Starting Power Level: Same as Output Power Accuracy Power Sweep Width and Linearity. See Figure 2</p>	

Supplemental Performance Characteristics are in *italics*

Table 1-1. Model HP 8341B Specifications and Supplemental Performance Characteristics (8 of 15)

RF OUTPUT (Cont'd)

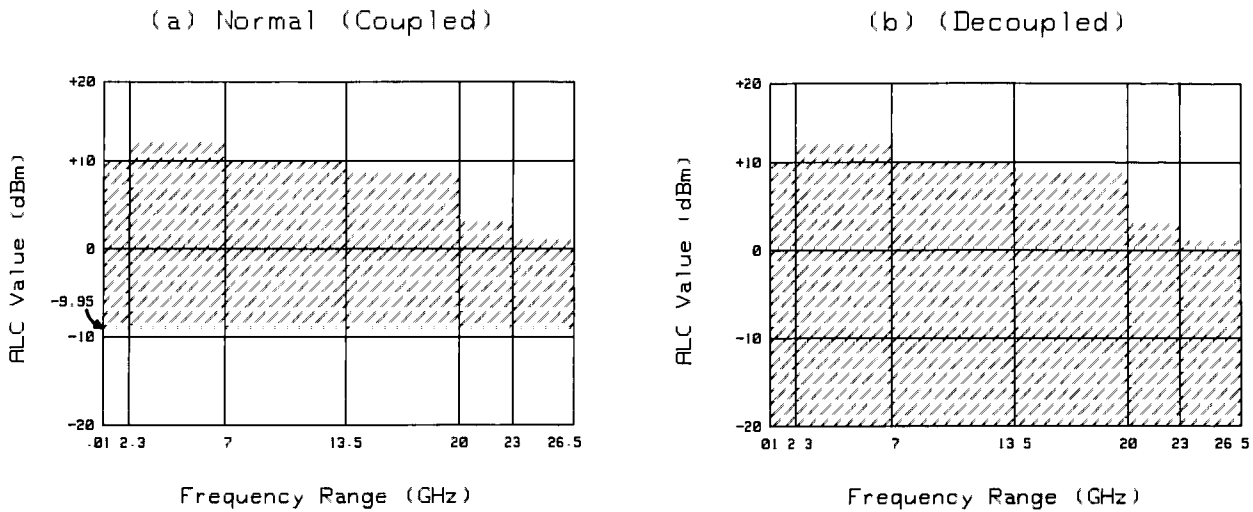

Figure 3. Typical Power Sweep Range

In normal operation (a), the ALC does not operate below -9.95 dBm (unless the instrument is placed in the Decoupled Mode by pressing **[SHIFT] [PWR SWP]**. See Figure 3), and so the maximum power sweep range is the difference of -9.95 dBm and the maximum leveled power available at the frequency of interest (specified leveled power shown in the diagram). In the DECOUPLED mode (b), the power sweep range is extended because the ALC can operate down to -20 dBm. The maximum power levels shown above do not apply to HP 8340Bs equipped with option 001, 004, or 005.

SLOPE COMPENSATION

Calibrated Range: 0 to 1.5 dB/GHz

Resolution: 0.001 dB/GHz

EXTERNAL LEVELING

XTAL: Allows the HP 8340B to be externally leveled by crystal detectors of positive or negative polarity

METER: Allows power meter leveling with any HP power meter

Range (XTAL or METER): 500 microvolts (-66 dBV) to 2.0 volts ($+6$ dBV)

Accuracy of voltage at EXT INPUT connector relative to the displayed level (leveling voltage is shown in ENTRY DISPLAY in dBV): ± 0.5 dB ± 0.2 mV typically.

Loop Bandwidth:

XTAL Mode. *Nominally 80 kHz* METER Mode. *Nominally 0.7 Hz*

Input Impedance: *Nominally 1 M Ohm.*

Supplemental Performance Characteristics are in italics

Table 1-1. Model HP 8340B Specifications and Supplemental Performance Characteristics (9 of 15)

PULSE MODULATION			
Not Applicable to HP 8340Bs Equipped with Option 006, Delete Pulse Modulation. (CW mode, and all specifications are typical for frequencies <400 MHz)			
ON/OFF RATIO: >80 dB			
RISE (T_R) AND FALL (T_F) TIMES: ≤25 nanoseconds			
MINIMUM INTERNALLY LEVELED RF PULSE WIDTH (T_{RF}): 100 nanoseconds			
MINIMUM UNLEVELED RF PULSE WIDTH: <i>Typically 25 nanoseconds</i>			
PULSE REPETITION FREQUENCY (PRF) Non-leveled operation (SHIFT METER): <i>Typically dc to 20 MHz</i> Internally leveled operation: 100 Hz to 5 MHz (<i>typically 100 Hz to 500 kHz for RF frequencies <400 MHz</i>).			
MAXIMUM PEAK POWER: Same as specified maximum leveled power. (See RF OUTPUT).			
ACCURACY OF INTERNALLY LEVELED RF PULSE V_p (relative to CW mode level): (Note that the ALC attempts to hold pulse amplitude to same level as leveled CW signal.)			
Bands and Approximate Frequency Ranges (GHz) (see Frequency Ranges and Bandswitch Points for complete description)			
Pulse Width	Band 0		Bands 1 - 4
	0.01 to 0.4	0.4 to <2.3	2.3 to 26.5
100 to <200 ns	—	+3/−0.3 dB*	+1.5/−0.3 dB*
200 to <500 ns	—	+1.5/−0.3 dB*	±0.3 dB
≥500 ns	—	±0.3 dB	±0.3 dB
1 to <2 μs	+3/−0.3 dB	—	—
2 to <5 μs	+1.5/−0.3 dB	—	—
≥5 μs	±0.3 dB	—	—
* +15 to +55°C. Duty Cycle must be ≥0.01%			
SIMULTANEOUS AM AND PULSE (Parameters shown are typical)			
AM BANDWIDTH AT 30% DEPTH DC coupled, typical 3 dB point:			
Internally Leveled		Unleveled (Shift Meter)*	
PRF/20** to a maximum of 5 kHz		100 kHz	
SETTLING TIME TO A STEP INPUT, 10%-90%, TYP:			
The greater of 70 μsec, or the time for the number of pulses indicated by the solid line below.		3.5 μsec	

Supplemental Performance Characteristics are in *italics*.

Table 1-1. Model HP 8340B Specifications and Supplemental Performance Characteristics (10 of 15)

PULSE MODULATION (Cont'd)	
<p>SETTLING TIME, NUMBER OF PULSES</p>	
<p>*[SHIFT] [METER] is an unleveled operating mode, power is controllable, but is not flat over frequency. AM bandwidth in this mode is independent of pulse rate and width. See Section I.</p> <p>**PRF = PULSE REPETITION FREQUENCY.</p>	
<p>OVERSHOOT, RINGING (V_{OR}/V_P): <i><15% typically</i></p>	
<p>PULSE WIDTH COMPRESSION ($T_V - T_{RF}$): <i>± 5 nanoseconds typically</i></p>	
<p>DELAY TIME (T_D): <i>50 nanoseconds typically</i></p>	
<p>VIDEO FEEDTHROUGH (V_F/V_P):</p> <p>0.01 to <0.4 GHz (Band 0): <i>$\leq 5\%$ typically (for output power levels $\leq +8$ dBm)</i></p> <p>0.4 to <2.3 GHz (Band 0): <i>$\leq 5\%$ (for output power levels $\leq +8$ dBm)</i></p> <p>2.3 to 26.5 GHz (Bands 1 - 4): <i>$\leq 0.2\%$</i></p>	
<p>SIDEBANDS (caused by a pulse input when PULSE is OFF):</p> <p><i>Typically -50 dBc with a 30 kHz squarewave input from 0.01 to 7.0 GHz.</i></p>	
<p>PULSE INPUT CONNECTOR:</p> <p>TTL compatible (Open circuit is TTL high level and keeps RF on) <i>Damage level is +12 Vdc, -20 Vdc Refer to Section III, Operation, for input circuit diagram.</i></p>	

Supplemental Performance Characteristics are in *italics*.

PULSE MODULATION (Cont'd)	
PULSE DEFINITIONS:	<p style="text-align: center;"> T_{RF} -RF Pulse Length T_R -RF Pulse Rise Time T_V -Input Pulse Length T_F -RF Pulse Fall Time T_D -Delay Time V_{OR} -Overshoot and Ringing V_P -RF Pulse Amplitude V_F -Video Feedthrough </p>
<i>Figure 4. Pulse Definitions</i>	
AMPLITUDE MODULATION	
<p>(The following specifications apply when the HP 8340B is internally leveled, for waveforms whose envelope peak is at least 1 dB below maximum specified power. Unless noted, pulse modulation must be OFF; however, the HP 8340B is capable of simultaneous amplitude and pulse modulation. See Section III, Operation.)</p>	
AM DEPTH: 0 to 90%	
<p>AM SENSITIVITY (at 1 kHz rate and 30% Depth): 100%/V \pm 5% RF amplitude is linearly controlled by varying AM input between 0 and \pm 1 Volt. PULSE ON: 100%/Volt typically for rates less than 0.1/ Settling Time.</p>	
<p>AM BANDWIDTH (relative to 1 kHz rate at 30% Depth): DC coupled, 3 dB point \geq 100 kHz PULSE ON: DC coupled, 3 dB point \geq PRF/20, typically. (Refer to Pulse Modulation specs for a more complete description)</p>	
AM FREQUENCY RESPONSE (FLATNESS) (relative to a 1 kHz rate at 30% depth, DC to 10 kHz): \pm 0.20 dB	
DISTORTION: Typical distortion values are given in Figure 5.	

Supplemental Performance Characteristics are in *italics*.

Table 1-1. Model HP 8340B Specifications and Supplemental Performance Characteristics (12 of 15)

AMPLITUDE MODULATION (Cont'd)

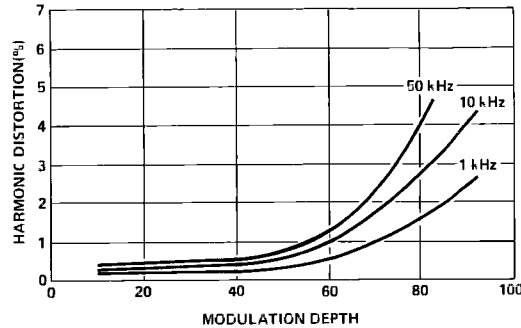

Figure 5. Typical AM Distortion for Various Modulation Rates and Depths

INCIDENTAL PHASE MODULATION (in peak radians) (Rates ≤ 10 kHz, 30% Depth): *<0.4 typically*

INCIDENTAL FM: *Incidental Phase Modulation \times Modulation Frequency*

AM INPUT IMPEDANCE: *Nominally 600 Ohms.*

FREQUENCY MODULATION

MODULATION RATE: 50 kHz to 10 MHz (3 dB bandwidth)

PEAK DEVIATION: The lesser of 10 MHz or:
 $n \times \text{Mod Rate}$
 where n = harmonic multiplication number (1 to 4). Refer to Frequency Ranges and Bandwidth Points Description

DEVIATION ACCURACY: $\pm 10\%$ (at 100 kHz rate)

SENSITIVITY: 1 MHz/Volt or 10 MHz/Volt

INPUT IMPEDANCE: *Nominally 50 Ohms*

SWEEP TIME

RANGE:

10 milliseconds to 200 seconds forward sweep times

Fastest possible sweep typically cycles once every 40 ms; fastest possible full band sweep typically cycles once every 150 ms.

MAXIMUM SPEED: *Nominally 600 MHz/ms*

RESOLUTION: *Approximately 0.1% of current sweep time value.*

ACCURACY: $\pm 5\%$ (sweeptimes ≤ 50 seconds)

Supplemental Performance Characteristics are in *italics*.

Table 1-1. Model HP 8340B Specifications and Supplemental Performance Characteristics (13 of 15)

INPUTS
<p>PULSE MODULATION INPUT (Not applicable to HP 8340Bs equipped with Option 006, Delete Pulse Modulation) Front panel BNC female input connector. TTL compatible (open circuit is TTL high level and keeps RF on). <i>Damage level is +12 Vdc, -20 Vdc.</i></p>
<p>AMPLITUDE MODULATION INPUT Front panel BNC female input connector. <i>Nominal input impedance is 600 Ohms.</i></p>
<p>FREQUENCY MODULATION INPUT Front panel BNC female connector. Nominal input impedance is 50 Ohms. Full scale input voltage = ± 1 vac. Damage to internal circuitry will result if a signal with a peak voltage of ± 8 vac or greater is input</p>
<p>LEVELING EXT INPUT Front panel BNC female input connector. Used for power meter leveling or crystal detector leveling. Input impedance in XTAL or METER modes is <i>nominally 1 MOhm</i>. Refer to EXTERNAL LEVELING specifications.</p>
<p>FREQUENCY STANDARD EXT Rear panel BNC female connector. Accepts 5 or 10 MHz signal from internal or external timebase. A BNC jumper connects this input to the HP 8340B's FREQUENCY STANDARD INT output for operation from HP 8340B's internal timebase. External signal input must be 5 MHz ± 50 Hz or 10 MHz ± 100 Hz, 0 to +10 dBm. <i>Nominal input impedance is 50 ohms.</i></p>
<p>EXT TRIGGER INPUT Rear panel BNC female connector. Triggers single sweep. Trigger signal must be >2 Vdc (10 Vdc max) and wider than 0.5 microseconds. <i>Nominal input impedance is 2 kOhms</i></p>
<p>STOP SWP IN/OUT: Rear panel BNC female connector. TTL high while sweeping, stops sweep when grounded externally. TTL low when HP 8340B stops sweep.</p>
<p>HP 8755C INTERFACE Rear panel. Connects via cable (HP Part No. 8120-3174) to HP 8755C Scalar Network Analyzer to provide Alternate Sweep function.</p>
<p>HP 8410B INTERFACE Rear panel 25-pin D-type connector. Permits multi-octave operation of HP 8410B/C Network Analyzer with HP 8340B via interface cable (HP Part No. 08410-60146). Also provides duplicates of these functions. Ext Trigger Input, Mute Output, Penlift Output, Neg Blank, and Z-Axis Blank/Mkrs. Also provides an input for a switch closure to execute the UP key function</p>
OUTPUTS
<p>RF OUTPUT Front panel Type N Female connector. Frequency output range is 10 MHz to 26.5 GHz. <i>Nominal output impedance is 50 Ohms.</i> SWR is shown in RF OUTPUT characteristics.</p>
<p>SWEEP OUTPUT Front and rear panel BNC female connectors. Supplies a voltage proportional to the sweep that ranges from <i>approximately 0 Vdc</i> (at start of sweep) to <i>approximately +10 Vdc</i> (at end of sweep), regardless of sweep width. In CW mode, the dc voltage is proportional to percentage of full 10 MHz to 26.5 GHz range</p>
<p>0.5V/GHz Rear panel BNC female connector which outputs a voltage proportional to the instrument's output frequency (<i>0.5V/GHz</i>). Nominal load impedance should be greater than or equal to <i>4 KOhms</i>. <i>Accuracy of this signal is $\pm 1\% \pm 2mV$</i>. This signal is intended for use with millimeter-wave source systems. This output can be changed to <i>1.0V/GHz</i> (for use with the HP 8410C) by adding jumpers W1 and W2 on the A28 SYTM Driver board. The maximum output voltage of this signal is <i>19 vdc</i>.</p>

Supplemental Performance Characteristics are in *italics*

Table 1-1. Model HP 8340B Specifications and Supplemental Performance Characteristics (14 of 15)

OUTPUTS (Cont'd)

10 MHz REF OUTPUT

Rear panel BNC female connector. Output power level is *nominally 0 dBm*, Output impedance is *nominally 50 Ohms*

FREQUENCY STANDARD INT

Rear panel BNC connector. Output frequency 10 MHz, output power *nominally 3 dBm*, 50 Ohm nominal output impedance. Jumpered to **FREQUENCY STANDARD EXT** for operation from HP 8340B's internal timebase

MUTE OUTPUT

Rear panel BNC female connector. Mutes servo motor of X-Y recorder when the HP 8340B crosses a band switchpoint.

PENLIFT OUTPUT J13

For operation with X-Y recorders PENLIFT disables an X-Y recorder's ability to lower its pen during sweep retrace. If **[SHIFT] [LINE]** is pressed on the front panel, PENLIFT will also disable the pen during forward sweep band switchpoints. Because of X-Y recorder limitations PENLIFT will always disable the X-Y recorder's pen at sweep times under 5 seconds.

PENLIFT enables pen operation by providing a current path to ground for the X-Y recorder's pen solenoid. The voltage at the PENLIFT output in this state will be *approximately 0 Vdc*. Circuit impedance in this state is *approximately 5 Ohms*

PENLIFT disables pen operation by not providing a current path to ground for the X-Y recorder's pen solenoid. The voltage on the PENLIFT output will be equal to the X-Y recorder's pen solenoid supply voltage. Circuit impedance in this state is very high.

NEG BLANK

Rear panel BNC female connector. Supplies negative rectangular pulse (*approximately -5 Vdc into 2 kOhm load*) during the retrace and band switchpoints of the RF output.

Z-AXIS BLANK/MKRS

Rear panel BNC female connector. Supplies positive rectangular pulse (*approximately +5 Vdc into 2 kOhms*) during the retrace and band switchpoints of the RF output. Also, supplies a *-5 Vdc* pulse when the RF is coincident with a marker frequency (intensity markers only).

AUX OUT

Rear panel Type-N female connector. Provides a 2.3 to 7.0 GHz fundamental oscillator output, *nominally 0 dBm and 50 Ohm output impedance*

REMOTE OPERATION

All functions (except line power) may be programmed via the Hewlett-Packard Interface Bus (HP-IB). Detailed Remote operation information is included in Section III, Operation.

GENERAL

ENVIRONMENTAL

Temperature: Operation at 0 to +55°C, except as noted in electrical specifications.

Humidity: Passes 5 day cycling, +40°C, 95% relative humidity.

EMI: Controlled and radiated interference is within the requirements of CE03 and RE02 (relaxed by 10 dB) of MIL STD 461A, and within the requirements of VDE 0871/1978, Level B and CISPR publication 11 (1975)

Supplemental Performance Characteristics are in *italics*.

Table 1-1. Model HP 8340B Specifications and Supplemental Performance Characteristics (15 of 15)

GENERAL (Cont'd)	
WARM-UP TIME	
<p>Operation: Requires 30-minute warmup from cold start, 0 to +55°C. Internal temperature equilibrium is reached after 2-hour warmup at stable outside temperature.</p> <p>Frequency Reference: Reference time base is kept at operating temperature in STANDBY mode with the instrument connected to the ac power. For instruments disconnected from ac power for less than 24 hours, the aging rate is $<1 \times 10^{-9}$/day after a 72-hour warmup.</p>	
POWER REQUIREMENTS	
47.5 to 66 Hz; 100, 120, 220, or 240 volts ($\pm 10\%$); <i>Typically, 500 VA maximum (40 VA in STANDBY).</i>	
WEIGHT	
<p>Net Weight: 34 kg (75 lb)</p> <p>Shipping Weight: 52 kg (112 lb)</p>	
DIMENSIONS	
<i>Figure 6. Instrument Dimensions</i>	
NOTES	
<ol style="list-style-type: none"> 1. Maximum leveled power from 35°C to 55°C will typically be degraded from these specifications by <i>no more than 2 dB</i>. 2. Internally leveled, AM off. The POWER dBm display monitors that actual output power, giving accurate readings when unleveled, externally leveled, or when amplitude modulating with a signal that has a dc component. In these modes, the accuracy <i>typically degrades by ± 0.1 dB</i> over the tabulated values. The ENTRY DISPLAY shows the desired power level, or the desired external detector output voltage, exclusive of modulation. 3. The ALC loop <i>typically operates up to +20 dBm</i> to enhance usability at those frequencies where leveled power greater than the maximum specified is available. 	

Supplemental Performance Characteristics are in *italics*.

Table 1-2. Model HP 8341B Specifications and Supplemental Performance Characteristics (1 of 15)

NOTE

Specifications are the performance standards, or limits, against which the instrument may be tested. The following Specifications apply for temperatures between 0 and +50°C except where noted. Specifications apply with the PEAK function ON in the CW and MANUAL modes of operation, and with periodic use of AUTO TRACKING CALIBRATION in swept operation.

Supplemental Performance Characteristics are in *italics* in this table and are intended to provide information useful in applying the instrument by giving typical, but non-warranted, performance parameters. These are denoted as "typical," "nominal," or "approximate."

FREQUENCY

CW MODE

Range: 0.01 to 20.0 GHz

Resolution: $n \times 1$ Hz

Where N = harmonic multiplication (1 to 3). Refer to Frequency ranges and Bandswitch Points description below.

Accuracy: Same as Time Base Accuracy

Time Base

Frequency: 10 MHz

Aging Rate:

1×10^{-9} per day, 2.5×10^{-7} per year after 72 hour warm up if HP 8341B has been disconnected from ac power for less than 24 hours. Aging rate is achieved after 7 to 30 days warm up if HP 8341B has been disconnected from ac power for greater than 24 hours

Temperature Coefficient: *Typically* $< 1 \times 10^{-10}$ per °C

Change due to 10% line voltage change: *Typically* $< 1 \times 10^{-11}$

Accuracy:

Overall accuracy of internal time base is a function of time base calibration \pm aging rate \pm temperature effects \pm line effects.

Switching Time: <50 msec (PEAK function off)

Fast Phase Lock Mode reduces typical switching time to <20 msec.)

CENTER FREQUENCY/SWEEP WIDTH MODE (CF/ Δ F)

Range: 10.00005 MHz to 19.99999995 GHz (**center frequency**)
100 Hz to 19 99 GHz (**sweep width**)

Resolution: *Approximately 0.1% of sweep width (Δ F)*

Readout Accuracy with respect to sweep out voltage (sweep time > 100 msec).

$\Delta \leq n \times 5$ MHz: $\pm 1\%$ of indicated sweep width (Δ F) \pm time base accuracy*

$\Delta > n \times 5$ MHz to < 300 MHz: $\pm 2\%$ of indicated sweep width (Δ F)

$\Delta \geq 300$ MHz: $\pm 1\%$ of indicated sweep width (Δ F), or ± 50 MHz, whichever is less.

Where n = harmonic multiplication number (1 to 3). Refer to Frequency Ranges and Bandswitch Points description below.

*Time Base effects Center Frequency accuracy only, not sweep width accuracy

Supplemental Performance Characteristics are in *italics*.

Table 1-2. Model HP 8341B Specifications and Supplemental Performance Characteristics (2 of 15)

FREQUENCY (Cont'd)
<p>START/STOP MODE</p> <p>Range Start: 10 MHz to 19.9999999 GHz Stop: 10 0001 MHz to 20 0 GHz</p> <p>Resolution: <i>Typically, the same as Center Frequency/Sweep Width mode:</i></p> <p>Readout Accuracy with respect to sweep out voltage (sweep time > 100 msec). Same as Center Frequency/Sweep Width Mode.</p>
<p>FREQUENCY MARKERS</p> <p>All 5 markers are independently variable and have the same specifications.</p> <p>Range: 10 MHz to 20 0 GHz</p> <p>Resolution: <i>Approximately 0.1% of sweep width (ΔF)</i></p> <p>Readout Accuracy (sweep time > 100 msec): Same as CENTER FREQUENCY/SWEEP WIDTH MODE (CF/ΔF).</p> <p>*Time base accuracy is not a factor in MKRΔ Mode</p>
<p>TYPICAL FREQUENCY RANGES AND BANDSWITCH POINTS</p> <p>For bands 0 and 1, the HP 8341B's output is derived from the fundamental frequency of its internal 2.3 to 7.0 GHz YIG-tuned oscillator ($n=1$). For bands 2 and 3, the output is derived from the 2nd or 3rd harmonic of the oscillator ($n = 2$ or 3).</p> <p>Bandswitch points in CW Mode (only) always occur at the following points:</p> <ul style="list-style-type: none">Band 0 to 1: 2.3 GHzBand 1 to 2: 7.0 GHzBand 2 to 3: 13.5 GHz <p>Bandswitch points in each of the swept modes (CF/ΔF, START/STOP) and the MANUAL SWEEP mode normally occur at the following points (with the exception listed below):</p> <ul style="list-style-type: none">Band 0 to 1: 2.4 GHzBand 1 to 2: 7.0 GHzBand 2 to 3: 13.5 GHz <p>The swept mode bandswitch points are illustrated in Figure 1.</p>

Supplemental Performance Characteristics are in *italics*.

Table 1-2. Model HP 8341B Specifications and Supplemental Performance Characteristics (3 of 15)

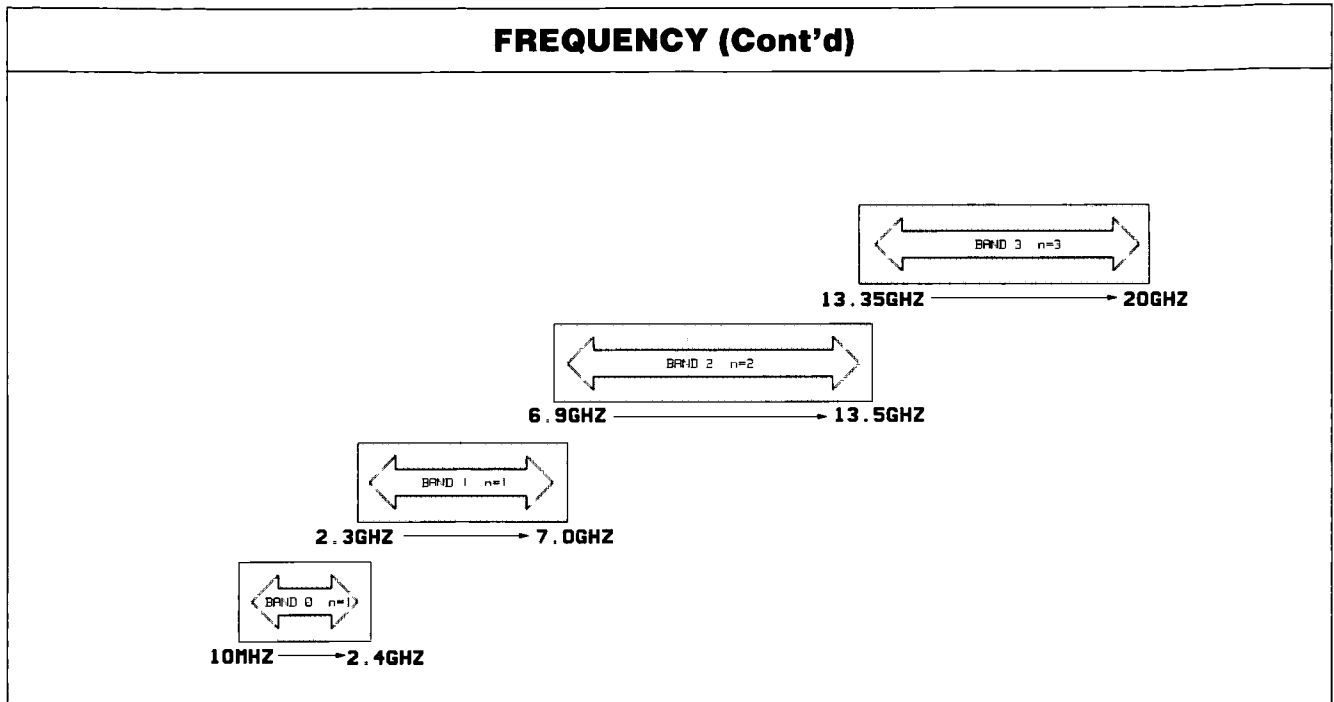

Figure 1. Typical Frequency Ranges and Bandswitch Points in Swept Modes

Note that the bands overlap. However, any sweep will be executed with the minimum number of bandswitch points. If the start frequency is above the lower limit for a given band, the sweep will start in that band and not the next lower one. If the stop frequency exceeds the upper limit of a given band by an amount greater than $0.004 \times \Delta F$, a bandswitch will occur at that band's upper limit.

SPECTRAL PURITY				
(Spectral Purity specifications apply for CW mode and all swept modes, unless otherwise stated.)				
SPURIOUS SIGNALS (Expressed in dB relative to the carrier level (dBc) at ALC level of 0 dBm)	Bands and Approximate Frequency Ranges (GHz) (See Frequency Ranges and Bandswitch Points for complete description)			
	Band 0 0.01 to <2.3	Band 1 2.3 to <7.0	Band 2 7.0 to <13.5	Band 3 13.5 to 20.0
Harmonics (only up to 20.0 GHz)	< -35	< -35	< -35	< -35
Subharmonics and multiples thereof (up to 20.0 GHz)	-	-	< -25	< -25
Non-harmonically related spurious (CW and Manual Sweep mode only)	< -50	< -70	< -64	< -60

Supplemental Performance Characteristics are in *italics*.

Table 1-2. Model HP 8341B Specifications and Supplemental Performance Characteristics (4 of 15)

SPECTRAL PURITY (Cont'd)				
SPURIOUS SIGNALS (Cont'd)				
Power line related and spurious due to fan rotation within 5 Hz below line frequency, and multiples thereof				
(CW mode only, all power levels)	Band 0 0.01 to <2.3	Band 1 2.3 to <7.0	Band 2 7.0 to <13.5	Band 3 13.5 to 20.0
Offset < 300 Hz from carrier	< -50	< -50	< -44	< -40
Offset 300 Hz to 1 kHz from carrier	< -60	< -60	< -54	< -50
Offset > 1 kHz from carrier	< -65	< -65	< -59	< -55
SINGLE-SIDEBAND PHASE NOISE (dBc/1 Hz BW, CW Mode, all power levels)				
Offset 30 Hz from carrier	< -64	< -64	< -58	< -54
Offset 100 Hz from carrier	< -70	< -70	< -64	< -60
Offset 1 kHz from carrier	< -78	< -78	< -72	< -68
Offset 10 kHz from carrier	< -86	< -86	< -80	< -76
Offset 100 kHz from carrier	< -107	< -107	< -101	< -97
TYPICAL FREQUENCY STABILITY, 50 Hz - 15 kHz post detection bandwidth				
Typical Residual FM in CW Mode: $< n \times 60 \text{ Hz rms}$				
Typical Residual FM in Swept Mode:				
$\Delta F > n \times 5 \text{ MHz. } < n \times 25 \text{ kHz rms}$				
$\Delta F \leq n \times 5 \text{ MHz: Same as CW mode}$				
Where n = harmonic multiplication number (1 to 3). Refer to Frequency Ranges and Bandswitch Points description above.				

Supplemental Performance Characteristics are in *italics*

Table 1-2. Model HP 8341B Specifications and Supplemental Performance Characteristics (5 of 15)

RF OUTPUT				
MAXIMUM LEVELED POWER (0°C to +35°C) ¹	Bands and Approximate Frequency Ranges (GHz) (See Frequency Ranges and Bandswitch Points for complete description)			
	Band 0	Band 1	Band 2	Band 3
	0.01 to <2.3	2.3 to <7.0	7.0 to <13.5	13.5 to 20.0
STANDARD INSTRUMENT	+10.0 dBm	+12.0 dBm	+10.0 dBm	+9.0 dBm
OPTION 004 (R.P. Out w/Atten.)	+10.0 dBm	+11.0 dBm	+9.0 dBm	+7.0 dBm
MINIMUM SETTABLE POWER -110 dBm				
RF OFF When the RF key is turned OFF, the POWER dBm display will read OFF and a 0 dBm signal will typically be reduced to a level < -100 dBm.				
OUTPUT POWER RESOLUTION "ENTRY DISPLAY": 0.05 dB "POWER dBm" Display: 0.1 dB				
OUTPUT POWER ACCURACY² STANDARD INSTRUMENT (Front Panel Output w/ Attenuator) +18 to +10 dBm ³ +10 to -9.95 dBm -10 to -19.95 dBm -20 to -49.95 dBm -50 to -79.95 dBm -80 to -99.95 dBm -100 to -110 dBm (typical)	Bands and Approximate Frequency Ranges (GHz) (See Frequency Ranges and Bandswitch Points for complete description)			
	Band 0 0.01 to <2.3	Bands 1 - 3 2.3 to 20		
	—	± 1.8 dB		
	± 0.9 dB	± 1.5 dB		
	± 1.2 dB	± 2.0 dB		
	± 1.5 dB	± 2.3 dB		
	± 1.8 dB	± 2.6 dB		
	± 2.1 dB	± 2.9 dB		
	± 2.9 dB	± 3.7 dB		
OPTION 004 (Rear Panel Output w/Attenuator) +18 to +10 dBm ³ +10 to -11.95 dBm -12 to -21.95 dBm -22 to -51.95 dBm -52 to -81.95 dBm -82 to -99.95 dBm -100 to -110 dBm (typical)				
	—	± 2.0 dB		
	± 1.0 dB	± 1.7 dB		
	± 1.3 dB	± 2.2 dB		
	± 1.6 dB	± 2.5 dB		
	± 1.9 dB	± 2.8 dB		
	± 2.2 dB	± 3.1 dB		
	± 3.0 dB	± 3.9 dB		

Supplemental Performance Characteristics are in *italics*

Table 1-2. Model HP 8341B Specifications and Supplemental Performance Characteristics (6 of 15)

RF OUTPUT (Cont'd)		
FLATNESS (Internally leveled)		
STANDARD INSTRUMENT (Front Panel Output w/Attenuator)	Band 0 0.01 to <2.3	Bands 1 - 3 2.3 to 20
+18 to +10 dBm ³	—	±1.2 dB
+10 to -9.95 dBm	±0.6 dB	±1.1 dB
-10 to -19.95 dBm	±0.9 dB	±1.6 dB
-20 to -49.95 dBm	±1.2 dB	±1.9 dB
-50 to -79.95 dBm	±1.4 dB	±2.2 dB
-80 to -99.95 dBm	±1.7 dB	±2.5 dB
-100 to -110 dBm (typical)	±1.9 dB	±3.1 dB
OPTION 004 (Rear Panel Output w/Attenuator)		
+18 to +10 dBm ³	—	±1.4 dB
+10 to -11.95 dBm	±0.7 dB	±1.3 dB
-12 to -21.95 dBm	±1.0 dB	±1.8 dB
-22 to -51.95 dBm	±1.3 dB	±2.1 dB
-52 to -81.95 dBm	±1.5 dB	±2.4 dB
-82 to -99.95 dBm	±1.8 dB	±2.7 dB
-100 to -110 dBm (typical)	±2.0 dB	±3.3 dB
TYPICAL ALC INCREMENTAL ACCURACY		
<p>Figure 2. Typical ALC Incremental Accuracy</p>		
<p>In normal operation the ALC does not operate below -9.95 dBm because the HP 8341B automatically increments the step attenuator at that point. However, when the ALC and step attenuator are independently controlled (DECOUPLED mode), the ALC may be operated over its full +20 dBm to -20 dBm range. Refer to Section III, Operation for a more detailed description. Pressing [SHIFT] [POWER SWP] places the instrument in the Decoupled Mode. In this mode the Data Entry keyboard and the rotary knob control the ALC level, and the step up and step down keys control the attenuator.</p>		

Supplemental Performance Characteristics are in *italics*.

Table 1-2. Model HP 8341B Specifications and Supplemental Performance Characteristics (7 of 15)

RF OUTPUT (Cont'd)	
RF OUTPUT CONNECTOR	
Output Impedance: <i>Nominally 50 Ohms</i> Typical Source SWR (Internally leveled only): 0.1 to <2.3 GHz: <i>Typically <1.3:1</i> 2.3 to <18.0 GHz: <i>Typically <1.6:1</i> 18.0 to 20.0 GHz: <i>Typically <1.8:1</i>	
STABILITY WITH TEMPERATURE: <i>Typically ± 0.01 dB/°C</i>	
OUTPUT LEVEL SWITCHING TIME: Typically <10 ms to be within 0.1 dB of final value with no attenuator range change (internally leveled only).	
POWER SWEEP	
Range: Displayed: 0 to 40 dB/sweep Actual: At least 10 dB at any given frequency (at least 20 dB in DECOUPLED mode; see Figure 3 below). Resolution: 0.05 dB/sweep Accuracy: Starting Power Level: Same as Output Power Accuracy Power Sweep Width and Linearity: See Figure 2	
<div style="display: flex; justify-content: space-around;"> <div style="text-align: center;"> <p>(a) Normal (Coupled)</p> </div> <div style="text-align: center;"> <p>(b) (Decoupled)</p> </div> </div>	
<p>Figure 3. Typical Power Sweep Range</p> <p>In normal operation (a), the ALC does not operate below -9.95 dBm (unless the instrument is placed in the Decoupled Mode by pressing [SHIFT] [PWR SWP]. See Figure 3), and so the maximum power sweep range is the difference of -9.95 dBm and the maximum leveled power available at the frequency of interest (specified leveled power shown in the diagram). In the DECOUPLED mode (b), the power sweep range is extended because the ALC can operate down to -20 dBm. The maximum power levels shown above do not apply to HP 8341Bs equipped with option 004</p>	

Supplemental Performance Characteristics are in *italics*.

Table 1-2. Model HP 8341B Specifications and Supplemental Performance Characteristics (8 of 15)

RF OUTPUT (Cont'd)	
SLOPE COMPENSATION	
Calibrated Range: 0 to 1.5 dB/GHz	Resolution: 0.0001 dB/GHz
EXTERNAL LEVELING	
XTAL: Allows the HP 8341B to be externally leveled by crystal detectors of positive or negative polarity.	
METER: Allows power meter leveling with any HP power meter.	
Range (XTAL or METER): 500 microvolts (−66 dBV) to 2.0 volts (+6 dBV)	
Accuracy of voltage at EXT INPUT connector relative to the displayed level (leveling voltage is shown in ENTRY DISPLAY in dBV). $\pm 0.5 \text{ dB} \pm 0.2 \text{ mV}$	
Loop Bandwidth:	
XTAL Mode: <i>Nominally 80 kHz</i> METER Mode: <i>Nominally 0.7 Hz</i>	
Input Impedance: <i>Nominally 1 M Ohm.</i>	
PULSE MODULATION	
(CW mode, and all specifications are typical for frequencies <400 MHz)	
ON/OFF RATIO: >80 dB	
RISE (T_R) AND FALL (T_F) TIMES: ≤25 nanoseconds	
MINIMUM INTERNALLY LEVELED RF PULSE WIDTH (T_{RF}): 100 nanoseconds	
MINIMUM UNLEVELED RF PULSE WIDTH: <i>Typically 25 nanoseconds</i>	
PULSE REPETITION FREQUENCY (PRF)	
Non-leveled operation (SHIFT METER): <i>Typically dc to 20 MHz.</i>	
Internally leveled operation: 100 Hz to 5 MHz (<i>typically 100 Hz to 500 kHz for RF frequencies <400 MHz.</i>)	
MAXIMUM PEAK POWER: Same as specified maximum leveled power. (See RF OUTPUT).	

Supplemental Performance Characteristics are in *italics*

Table 1-2. Model HP 8341B Specifications and Supplemental Performance Characteristics (9 of 15)

PULSE MODULATION (Cont'd)			
Bands and Approximate Frequency Ranges (GHz) (see Frequency Ranges and Bandswitch Points for complete description)			
ACCURACY OF INTERNALLY LEVELED RF PULSE V_p (relative to CW mode level): (Note that the ALC attempts to hold pulse amplitude to save level as leveled CW signal)			
Pulse Width	Band 0		Bands 1 - 3
	0.01 to 0.4	0.4 to <2.3	2.3 to 20.0
100 to <200 ns	—	+3/−0.3 dB*	+1.5/−0.3 dB*
200 to <500 ns	—	+1.5/−0.3 dB*	±0.3 dB
≥500 ns	—	±0.3 dB	±0.3 dB
1 to <2 μs	+3/−0.3 dB	—	—
2 to <5 μs	+1.5/−0.3 dB	—	—
≥5 μs	±0.3 dB	—	—
*+15 to +55°C. Duty Cycle must be >0.01%			
SIMULTANEOUS AM AND PULSE (Parameters shown are typical)			
AM BANDWIDTH AT 30% DEPTH DC coupled, typical 3 dB point:			
Internally Leveled		Unleveled (Shift Meter)*	
PRF/20** to a maximum of 5 kHz		100 kHz	
SETTLING TIME TO A STEP INPUT, 10%-90%, TYP:			
The greater of: 70 μsec. or the time for the number of pulses indicated by the solid line below.		3.5 μsec	
<p style="text-align: center;">SETTLING TIME, NUMBER OF PULSES</p> <p style="text-align: center;">WIDTH (MICROSECONDS)</p>			
<p>*[SHIFT] [METER] is an unleveled operating mode, power is controllable, but is not flat over frequency. AM bandwidth in this mode is independent of pulse rate and width. See Section I.</p> <p>**PRF = PULSE REPETITION FREQUENCY.</p>			

Supplemental Performance Characteristics are in *italics*

Table 1-2. Model HP 8341B Specifications and Supplemental Performance Characteristics (10 of 15)

PULSE MODULATION (Cont'd)									
OVERSHOOT, RINGING (V_{OR}/V_P): <15% typically									
PULSE WIDTH COMPRESSION ($T_V - T_{RF}$): ± 5 nanoseconds typically									
DELAY TIME (T_D): 50 nanoseconds typically									
VIDEO FEEDTHROUGH (V_F/V_P): 0.01 to <0.4 GHz (Band 0): $\leq 5\%$ typically (for output power levels $\leq +8$ dBm) 0.4 to <2.3 GHz (Band 0): $\leq 5\%$ (for output power levels $\leq +8$ dBm) 2.3 to 20.0 GHz (Bands 1 - 3): $\leq 0.2\%$									
SIDEBANDS (caused by a pulse input when PULSE is OFF): Typically -50 dBc with a 30 kHz squarewave input from 0.01 to 7.0 GHz.									
PULSE INPUT CONNECTOR: TTL compatible. (Open circuit is TTL high level and keeps RF on) Damage level is +12 Vdc, -20 Vdc Refer to Section III, Operation, for input circuit diagram.									
PULSE DEFINITIONS:									
<table style="width: 100%; border: none;"> <tr> <td style="width: 50%; border: none;">T_{RF} -RF Pulse Length</td> <td style="width: 50%; border: none;">T_R -RF Pulse Rise Time</td> </tr> <tr> <td style="border: none;">T_V -Input Pulse Length</td> <td style="border: none;">T_F -RF Pulse Fall Time</td> </tr> <tr> <td style="border: none;">T_D -Delay Time</td> <td style="border: none;">V_{OR} -Overshoot and Ringing</td> </tr> <tr> <td style="border: none;">V_P -RF Pulse Amplitude</td> <td style="border: none;">V_F -Video Feedthrough</td> </tr> </table>		T_{RF} -RF Pulse Length	T_R -RF Pulse Rise Time	T_V -Input Pulse Length	T_F -RF Pulse Fall Time	T_D -Delay Time	V_{OR} -Overshoot and Ringing	V_P -RF Pulse Amplitude	V_F -Video Feedthrough
T_{RF} -RF Pulse Length	T_R -RF Pulse Rise Time								
T_V -Input Pulse Length	T_F -RF Pulse Fall Time								
T_D -Delay Time	V_{OR} -Overshoot and Ringing								
V_P -RF Pulse Amplitude	V_F -Video Feedthrough								
<i>Figure 4. Pulse Definitions</i>									

Supplemental Performance Characteristics are in *italics*.

Table 1-2. Model HP 8341B Specifications and Supplemental Performance Characteristics (11 of 15)

AMPLITUDE MODULATION	
(The following specifications apply when the HP 8341B is internally leveled, for waveforms whose envelope peak is at least 1 dB below maximum specified power. Unless noted, pulse modulation must be OFF, however, the HP 8341B is capable of simultaneous amplitude and pulse modulation. See Section III, Operation.)	
AM DEPTH: 0 to 90%	
AM SENSITIVITY (at 1 kHz rate and 30% Depth): 100%/V \pm 5% RF amplitude is linearly controlled by varying AM input between 0 and \pm 1 Volt PULSE ON: 100%/Volt typically for rates less than 0.1/Settling Time.	
AM BANDWIDTH (relative to 1 kHz rate at 30% Depth): DC coupled, 3 dB point \geq 100 kHz PULSE ON: DC coupled, 3 dB point \geq PRF/20, typically (Refer to Pulse Modulation specs for a more complete description.)	
AM FREQUENCY RESPONSE (FLATNESS) (relative to a 1 kHz rate at 30% depth, DC to 10 kHz): \pm 0.20 dB	
DISTORTION: Typical distortion values are given in Figure 5.	
<i>Figure 5. Typical AM Distortion for Various Modulation Rates and Depths</i>	
INCIDENTAL PHASE MODULATION (in peak radians) (Rates \leq10 kHz, 30% Depth): <0.4 typically	
INCIDENTAL FM: <i>Incidental Phase Modulation \times Modulation Frequency</i>	
AM INPUT IMPEDANCE: <i>Nominally 600 Ohms.</i>	
FREQUENCY MODULATION	
MODULATION RATE: 50 kHz to 10 MHz (3 dB bandwidth)	
PEAK DEVIATION: The lesser of 10 MHz or: $n \times$ Mod Rate where n = harmonic multiplication number (1 to 3). Refer to Frequency Ranges and Bandswitch Points Description.	
DEVIATION ACCURACY: \pm 10% (at 100 kHz rate)	
SENSITIVITY: 1 MHz/Volt or 10 MHz/Volt	
INPUT IMPEDANCE: <i>Nominally 50 Ohms</i>	

Supplemental Performance Characteristics are in *italics*.

Table 1-2. Model HP 8341B Specifications and Supplemental Performance Characteristics (12 of 15)

SWEEP TIME

RANGE:

10 milliseconds to 200 seconds forward sweep times

Fastest possible sweep typically cycles once every 40 ms; fastest possible full band sweep typically cycles once every 150 ms.

MAXIMUM SPEED: *Nominally 600 MHz/ms*

RESOLUTION: *Approximately 0.1% of current sweep time value*

ACCURACY: $\pm 5\%$ (sweeptimes ≤ 50 seconds)

INPUTS

PULSE MODULATION INPUT

Front panel BNC female input connector. TTL compatible (open circuit is TTL high level and keeps RF on). *Damage level is +12 Vdc, -20 Vdc*

AMPLITUDE MODULATION INPUT

Front panel BNC female input connector. *Nominal input impedance is 600 Ohms.*

FREQUENCY MODULATION INPUT

Front panel BNC female connector. Nominal input impedance is 50 Ohms. Full scale input voltage = ± 1 vac. Damage to internal circuitry will result if a signal with a peak voltage of ± 8 vac or greater is input.

LEVELING EXT INPUT

Front panel BNC female input connector. Used for power meter leveling or crystal detector leveling. Input impedance in XTAL or METER modes is *nominally 1 MOhm*. Refer to EXTERNAL LEVELING specifications.

FREQUENCY STANDARD EXT

Rear panel BNC female connector. Accepts 5 or 10 MHz signal from internal or external timebase. A BNC jumper connects this input to the HP 8341B's FREQUENCY STANDARD INT output for operation from HP 8341B's internal timebase. External signal input must be 5 MHz ± 50 Hz or 10 MHz ± 100 Hz, 0 to + dBm. *Nominal input impedance is 50 ohms.*

EXT TRIGGER INPUT

Rear panel BNC female connector. Triggers single sweep. Trigger signal must be >2 Vdc (10 Vdc max) and wider than 0.5 microseconds. *Nominal input impedance is 2 kOhms.*

STOP SWP IN/OUT:

Rear panel BNC female connector. TTL high while sweeping, stops sweep when grounded externally. TTL low when HP 8341B stops sweep.

HP 8755C INTERFACE

Rear panel. Connects via cable (HP Part No. 8120-3174) to HP 8755C Scalar Network Analyzer to provide Alternate Sweep function.

HP 8410B INTERFACE

Rear panel 25-pin D-type connector. Permits multi-octave operation of HP 8410B/C Network Analyzer with HP 8341B via interface cable (HP Part No. 08410-60146). Also provides duplicates of these functions: **Ext Trigger Input, Mute Output, Penlift Output, Neg Blank, and Z-Axis Blank/Mkrs.** Also provides an input for a switch closure to execute the UP key function.

Supplemental Performance Characteristics are in *italics*.

Table 1-2. Model HP 8341B Specifications and Supplemental Performance Characteristics (13 of 15)

OUTPUTS

RF OUTPUT

Front panel Type N Female connector. Frequency output range is 10 MHz to 20.0 GHz. *Nominal output impedance is 50 Ohms.* SWR is shown in RF OUTPUT characteristics.

SWEEP OUTPUT

Front and rear panel BNC female connectors. Supplies a voltage proportional to the sweep that ranges from *approximately 0 Vdc* (at start of sweep) to *approximately +10 Vdc* (at end of sweep), regardless of sweep width. In CW mode, the dc voltage is proportional to percentage of full 10 MHz to 20.0 GHz range.

0.5V/GHz

Rear panel BNC female connector which outputs a voltage proportional to the instrument's output frequency (*0.5V/GHz*). Nominal load impedance should be greater than or equal to *4 KOhms*. *Accuracy of this signal is $\pm 1\% \pm 2mV$.* This signal is intended for use with millimeter-wave source systems. This output can be changed to *1.0V/GHz* (for use with the HP 8410C) by adding jumpers W1 and W2 on the A28 SYTM Driver board. The maximum output voltage of this signal is *19 vdc*.

10 MHz REF OUTPUT

Rear panel BNC female connector. Output power level is *nominally 0 dBm*, Output impedance is *nominally 50 Ohms*.

FREQUENCY STANDARD INT

Rear panel BNC connector. *Output frequency 10 MHz, output power nominally 3 dBm, 50 Ohm nominal output impedance* Jumpered to **FREQUENCY STANDARD EXT** for operation from HP 8341B's internal timebase

MUTE OUTPUT

Rear panel BNC female connector. Mutes servo motor of X-Y recorder when the HP 8341B crosses a band switchpoint.

PENLIFT OUTPUT J13

For operation with X-Y recorders. PENLIFT disables an X-Y recorder's ability to lower its pen during sweep retrace. If **[SHIFT] [LINE]** is pressed on the front panel, PENLIFT will also disable the pen during forward sweep band switchpoints. Because of X-Y recorder limitations PENLIFT will always disable the X-Y recorder's pen at sweep times under 5 seconds.

PENLIFT enables pen operation by providing a current path to ground for the X-Y recorder's pen solenoid. The voltage at the PENLIFT output in this state will be *approximately 0 Vdc*. Circuit impedance in this state is *approximately .5 Ohms*.

PENLIFT disables pen operation by not providing a current path to ground for the X-Y recorder's pen solenoid. The voltage on the PENLIFT output will be equal to the X-Y recorder's pen solenoid supply voltage. Circuit impedance in this state is very high.

NEG BLANK

Rear panel BNC female connector. Supplies negative rectangular pulse (*approximately -5 Vdc into 2 kOhm load*) during the retrace and band switchpoints of the RF output.

Z-AXIS BLANK/MKRS

Rear panel BNC female connector. Supplies positive rectangular pulse (*approximately +5 Vdc into 2 kOhms*) during the retrace and band switchpoints of the RF output. Also, supplies a *-5 Vdc* pulse when the RF is coincident with a marker frequency (intensity markers only).

AUX OUT

Rear panel Type-N female connector. Provides a *2.3 to 7.0 GHz* fundamental oscillator output, *nominally 0 dBm and 50 Ohm output impedance*.

Supplemental Performance Characteristics are in *italics*

Table 1-2. Model HP 8341B Specifications and Supplemental Performance Characteristics (14 of 15)

REMOTE OPERATION	
All functions (except line power) may be programmed via the Hewlett-Packard Interface Bus (HP-IB). Detailed Remote operation information is included in Section III, Operation.	
GENERAL	
ENVIRONMENTAL	
Temperature: Operation at 0 to +55°C, except as noted in electrical specifications.	
Humidity: Passes 5 day cycling, +40°C, 95% relative humidity.	
EMI: Controlled and radiated interference is within the requirements of CE03 and RE02 (relaxed by 10 dB) of MIL STD 461A, and within the requirements of VDE 0871/1978, Level B and CISPR publication 11 (1975)	
WARM-UP TIME	
Operation: Requires 30-minute warmup from cold start, 0 to +55°C. Internal temperature equilibrium is reached after 2-hour warmup at stable outside temperature.	
Frequency Reference: Reference time base is kept at operating temperature in STANDBY mode with the instrument connected to the ac power. For instruments disconnected from ac power for less than 24 hours, the aging rate is $<1 \times 10^{-9}$ /day after a 72-hour warmup.	
POWER REQUIREMENTS	
47.5 to 66 Hz, 100, 120, 220, or 240 volts ($\pm 10\%$), <i>Typically, 500 VA maximum (40 VA in STANDBY).</i>	
WEIGHT	
Net Weight: 34 kg (75 lb)	
Shipping Weight: 52 kg (112 lb)	
DIMENSIONS	
<i>Figure 6. Instrument Dimensions</i>	

Supplemental Performance Characteristics are in *italics*.

Table 1-2. Model HP 8341B Specifications and Supplemental Performance Characteristics (15 of 15)

NOTES

1. Maximum leveled power from 35°C to 55°C will typically be degraded from these specifications by *no more than 2 dB*.
2. Internally leveled, AM off. The POWER dBm display monitors that actual output power, giving accurate readings when unleveled, externally leveled, or when amplitude modulating with a signal that has a dc component. In these modes, the accuracy *typically degrades by ± 0.1 dB* over the tabulated values. The ENTRY DISPLAY shows the desired power level, or the desired external detector output voltage, exclusive of modulation.
3. The ALC loop *typically operates up to +20 dBm* to enhance usability at those frequencies where leveled power greater than the maximum specified is available.

Supplemental Performance Characteristics are in *italics*.