



# ***CDM-600***

---

Open Network Satellite Modem (2.4 kbps – 20 Mbps)  
Installation and Operation Manual  
For Firmware Version 2.0.1 or higher  
(see ***New in this Release*** – Section 1.5)

**IMPORTANT NOTE:** The information contained in this document supercedes all previously published information regarding this product. Product specifications are subject to change without prior notice.





# CDM-600

## Open Network Satellite Modem Manual Addendum A

**Subject: Update for new Drop and Insert capability**  
**Part Number: MN/CDM600.AA7**  
**Revision 7 Addendum A**  
**October 10, 2005**

### **Special Instructions:**

This document contains changes and new information for the CDM-600 Open Network Satellite Modem manual, part number MN/CDM600.IOM Rev. 7 dated February 9, 2005.



**Comtech EF Data is an ISO 9001 Registered Company**

Copyright © Comtech EF Data Corporation, 2003,2004,2005.  
All rights reserved.  
Printed in the USA.

Comtech EF Data Corporation, 2114 W. 7<sup>th</sup> Street, Tempe, Arizona 85281 USA, (480) 333-2200, FAX: (480) 333-2161.

## New Features/Changes

- **Changes to Drop and Insert**

Since Version 7 of the CDM-600 Manual was published, there has been engineering development to modify the E1 Drop and Insert feature to add high-rate ESC (Engineering Service Channel) and AUPC (Automatic Uplink Power Control).

- **New remote control commands**

Two new commands have been added to query the Tx and Rx symbol rates. These are **TSR?** and **RSR?** respectively (query-only). This information was already displayed on the front panel, but had not been available via the remote port.

A front panel lockout feature has been added. Already, when in remote mode, user access of the front panel of the modem allows viewing of the configuration parameters, but does not allow changes to the configuration parameters. To make changes via the front panel, the user must first configure the modem for Local control via the Remote menu. This front panel lockout (**FPL**) feature, when activated, prevents or *locks-out* that ability to configure the modem into local mode from the front panel.

Refer to the remote control command table, following, for more detail.

---

## 6.1 Description of D&I with ESC and AUPC

The Drop and Insert (D&I) framing has been extended with the release of firmware version 2.1.0 to include the capability of adding high-rate ESC (Engineering Service Channel) and AUPC (Automatic Uplink Power Control). Currently this is available for E1 operation only. Refer to the manual for details of each of these features

The high-rate ESC channel operates the same for D&I as it does for IBS framing, using bytes 16 and 48 of the overhead channel, as well as half of byte 32, to pass the data characters over the satellite link. Because these bits are reserved for signaling, this new feature is not available for E1-CAS mode. The AUPC portion (which is not available with IBS framing) occupies the unused first bit of the unique word (byte 0).

To enable Drop and Insert with ESC and AUPC, the correct **sequence** of configuration must be followed. This applies when configuring via the front panel, or when using individual remote control commands. Prior to this new firmware version 2.1.0, neither ESC nor AUPC could be combined with D&I.

Configuration sequence:

	<u>Parameter</u>	<u>Setting</u>	<u>Detailed in section</u>
1	Mode:	D&I	6.3.1.2 (requires D&I FAST option)
2	D&I type:	E1-CCS	6.3.1.6
3	ESC	On	6.3.1.8
4	Power level mode:	AUPC	6.3.1.3

The available ESC baud rates for D&I depend on Tx and Rx datarate. They are the same as those for high-rate IBS ESC. Pin-out information for the Overhead Interface Connector which carries the ESC channel is shown in section 5.3.

The maximum ESC baud rate is limited by the lower of the Tx or Rx data rates. If a data rate is edited so that a baud rate is no longer available, the baud rate will automatically be reduced to the next permitted value. The data-rate breakpoints are:

<u>Data rate</u>	<u>Max ESC baud rate</u>	
64 kbps	2400	
> = 128 kbps	4800	
> = 256 kbps	9600	
> = 384 kbps	14400	
> = 512 kbps	19200	
> = 768 kbps	28800	
> =1280 kbps	38400	(Note: breakpoint change)

Note: For AUPC to be effective, it must be enabled on both the local & remote modems.

Parameter Type	Command (Instruction Code and Qualifier)	Arguments for Command or Response to Query	Description of Arguments	Response to Command	Query (Instruction Code and Qualifier)	Response to Query
Tx Symbol Rate	N/A	9 bytes, numeric	<p>Query only. This command allows remote access to the Tx symbol rate. This value is shown on the front panel.</p> <p>Format is ddddd.dddd</p>	<p>TSR? TSR=</p>	TSR?	TSR=dddd.dddd (see description of arguments)
Rx Symbol Rate	N/A	9 bytes, numeric	<p>Query only. This command allows remote access to the Rx symbol rate. This value is shown on the front panel.</p> <p>Format is ddddd.dddd</p>	<p>RSR? RSR=</p>	RSR?	RSR=dddd.dddd (see description of arguments)
Front Panel Lockout	FPL=	1 byte, numeric	<p>Command or query. Control the state of front-panel lockout, where: 0 = no lockout 1 = front panel lockout active.</p> <p>Disable the lockout by either FPL=0, or by setting into local mode using LRS=0.</p>	<p>FPL= FPL? FPL* FPL#</p>	FPL?	FPL=x (see description of arguments)

## Addendum B

# CDM-600

---

Open Network Satellite Modem (2.4 kbps – 20 Mbps)  
Installation and Operation Manual  
For Firmware Version 2.0.1 or higher  
(see *New in this Release* – Section 1.5)

**Subject:** Replacement of Appendix A. CABLE DRAWINGS

**Date:** October 13, 2008

**Original Manual Part Number/Rev:** MN/CDM600.IOM Rev 7

**Addendum Number / Agile Document ID:** AD-CDM600-AB7 **Agile CO Number** CO5356

**Notes:**

1. Insert this title page immediately *after* the manual title page to indicate that the manual was updated with this addendum.
2. To identify changes made to the previous edition, refer to the change bars located in the outside margins. [or:] Change bars were not utilized.

## Change Specifics:

This information will be incorporated into the next revision.

## Collating Instructions

To update the manual, remove and insert the pages as follows:

Remove	Insert
Appendix A (pages A-1 through A-4)	Appendix A (pages A-1 through A-6)



# Appendix A. CABLE DRAWINGS

---

## A.1 Introduction

The EIA-530 standard pinout provided on the CDM-600 is becoming more popular in many applications. However, there are still occasions, particularly with existing EIA-422/449 and V.35 users, when a conversion must be made.

For situations where such conversions are required, refer to the following table to select the appropriate cable.

In addition, the standard EIA-232 cable used for performing Flash Upgrading is depicted. This cable connects the CDM-600 Remote Control Port to the serial communications port of an external PC.

App. A FIG	CEFD CABLE P/N	DESCRIPTION
A-1	CA/WR0049	Modem Conversion Cable: EIA-530 → RS-422/449 DCE Conversion (DB-25M → DB-25F, 40")
A-2	CA/WR0059-2	Modem Conversion Cable: EIA-530 → V.35 Winchester DCE Conversion (DB-25M → Winchester 34-pin Female, 8')
A-3	CA/WR9718-1	Modem Conversion Cable: CDM → EIA-530 Conversion (DB-25M → DB-25F, 8')
A-4	N/A	Modem Conversion Cable: EIA-530 → V.35 Winchester DCE Conversion (DB-25M → Winchester 34-pin Female)
A-5	N/A	EIA-232 Switch Programming Cable (for Flash upgrading): CDM-600 Remote Port → PC Serial Port (DB-9F → DB-9F)

### A.1.1 EIA-530 to RS-422/449 Data Cable

Figure A-1 shows the cable drawing for EIA-530 to RS-422/449 DCE conversion for connections between the CDM-600 and the User data.

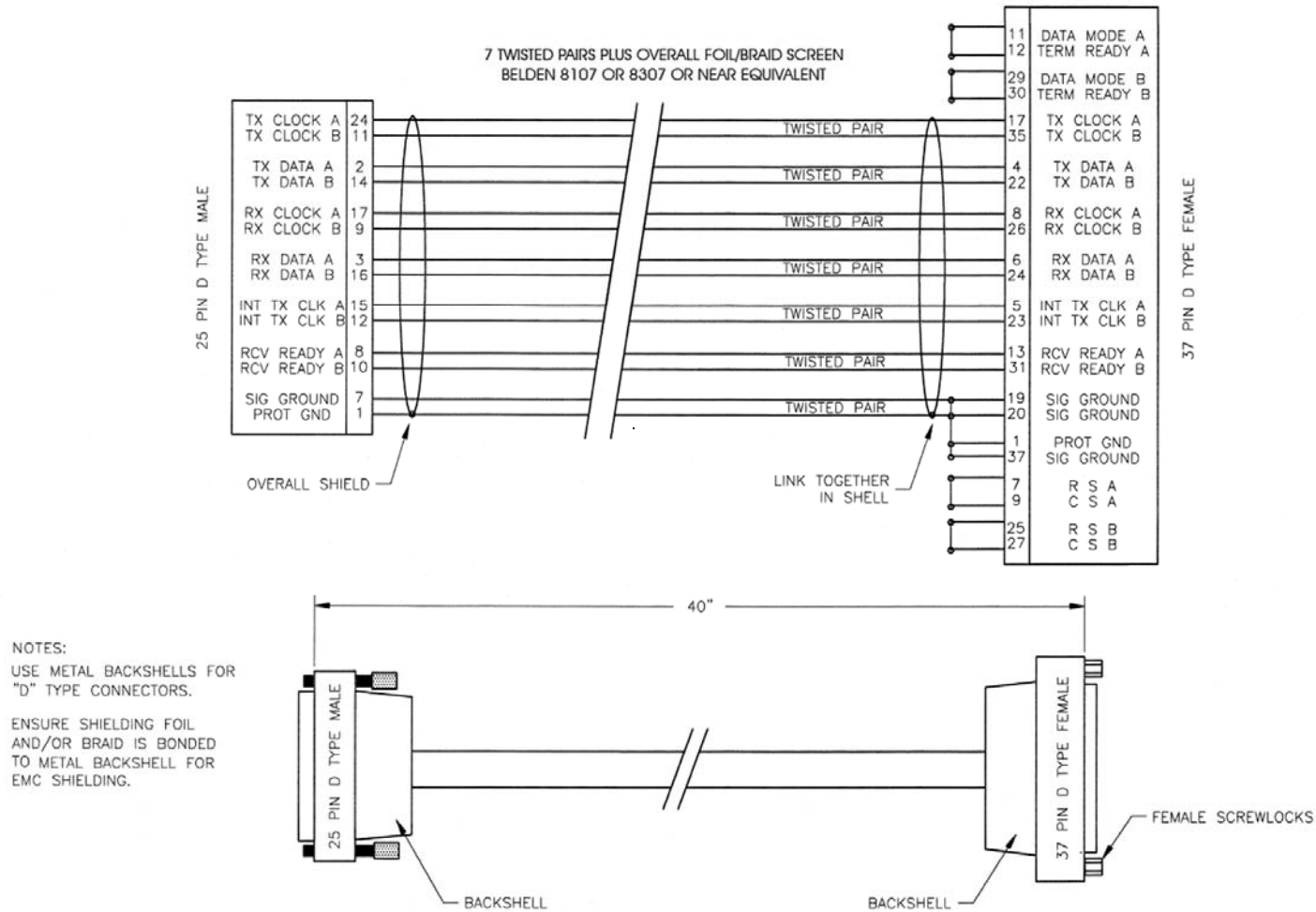

Figure A-1. DCE Conversion Cable: EIA-530 to RS-422/449 (CA/WR0049)

### A.1.2 EIA-530 to V.35 Data Cable

Figure A-2 shows the cable drawing for EIA-530 to V.35 DCE conversion for connections between the CDM-600 and the User data.

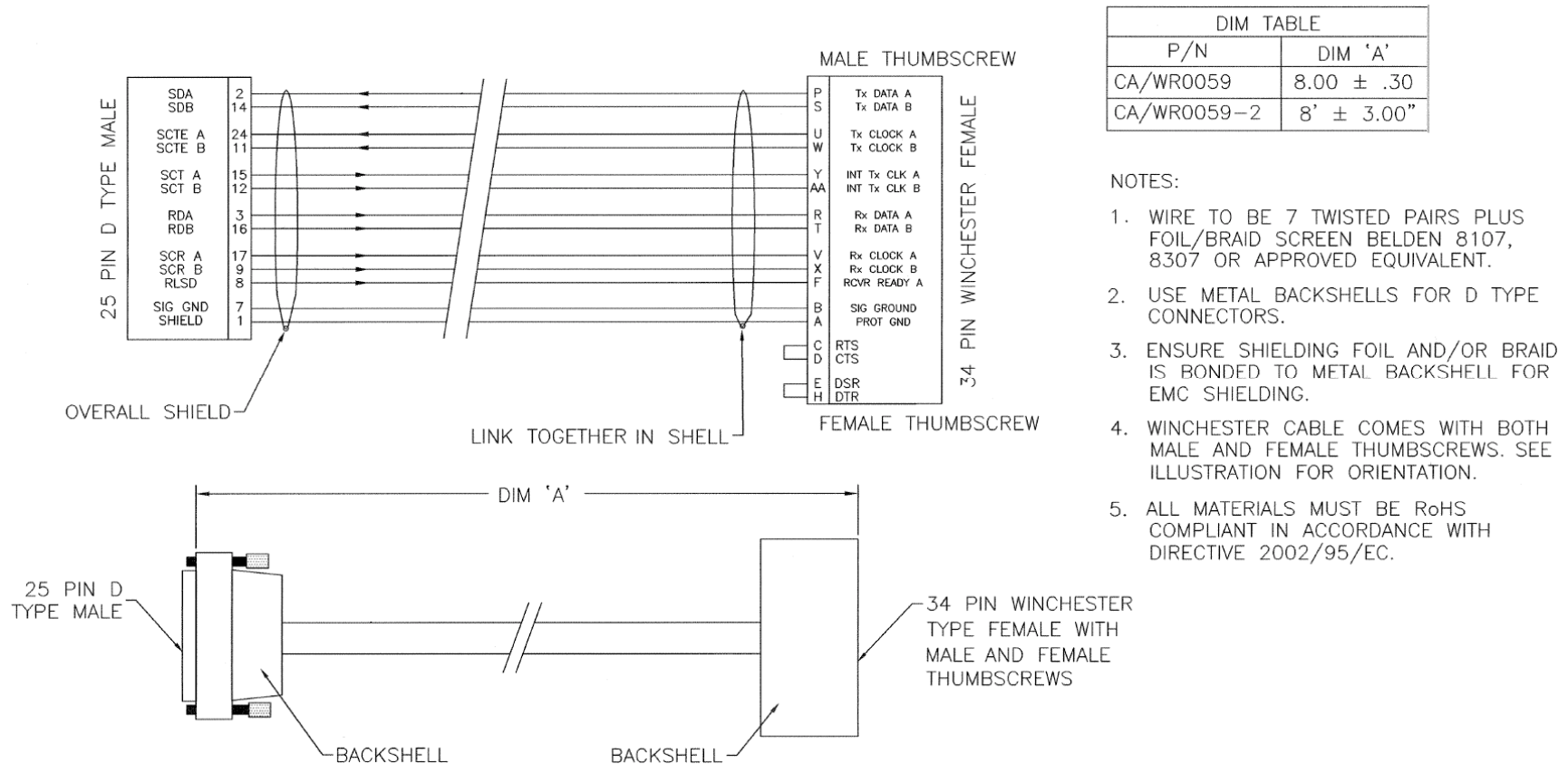

Figure A-2. DCE Conversion Cable: EIA-530 to V.35 (CA/WR0059)

### A.1.3 EIA-530 to V.35 Data Cable

Figure A-3 shows the cable drawing for modem to EIA-530 conversion for connections between the CDM-600 and the User data.

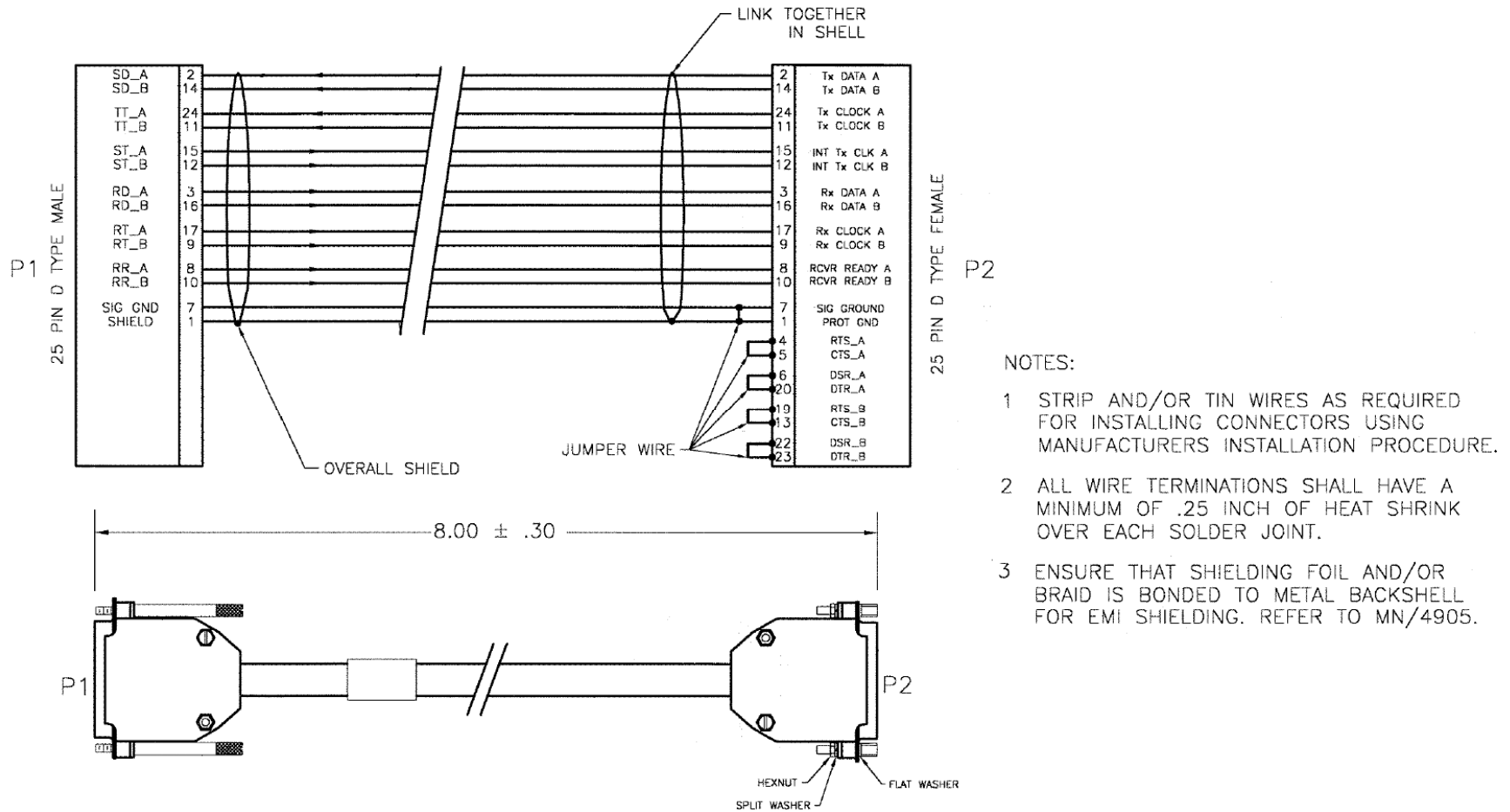

Figure A-3. DCE Conversion Cable: EIA-530 (CA/WR9718-1)

### A.1.4 EIA-530 Conversion Cable

Figure A-4 shows the cable drawing for EIA-530 to V.35 DCE conversion for connections between the CDM-600 and the User data.

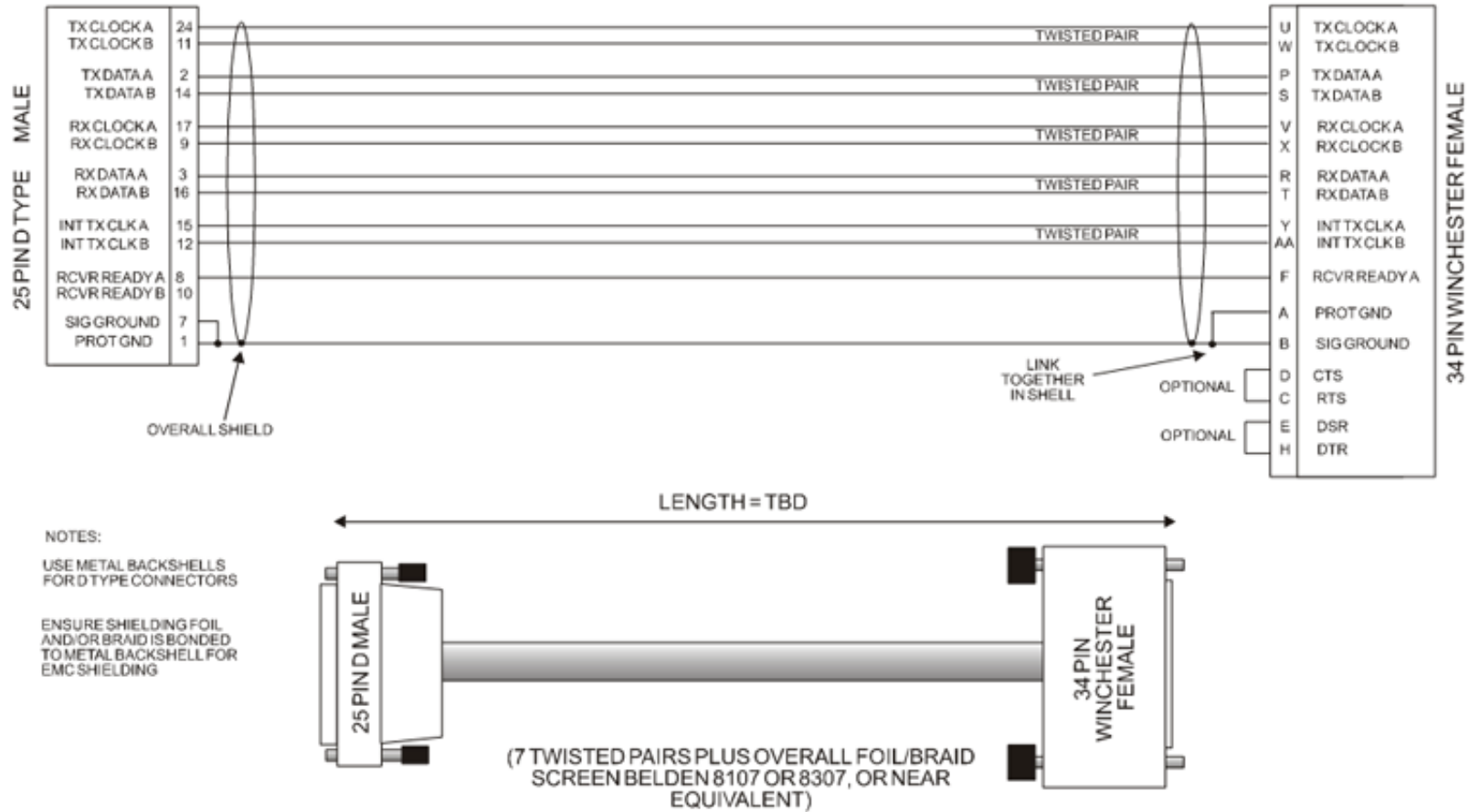
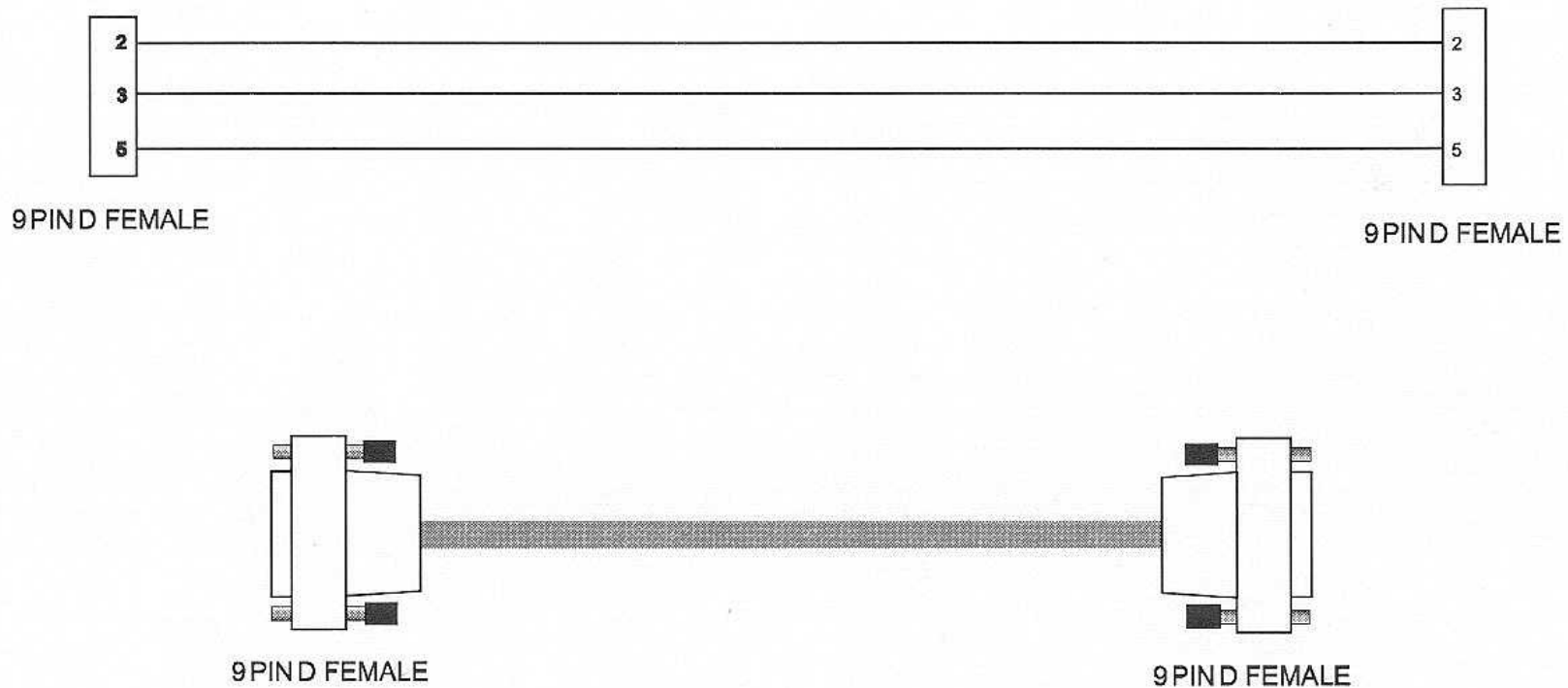

Figure A-4. DCE Conversion Cable: EIA-530 to V.35

### A.1.5 Switch Programming Cable

**Figure A-5** shows the cable required for a simple EIA-232 connection between the CDM-600 Remote Control port and an external PC serial port. This cable is needed for Flash upgrading.



**Figure A-5. Switch Programming Cable**



# Errata A

## *Comtech EF Data Documentation Update*

**Subject:** Change AUPC Parameters in Remote Control

**Date:** November 23, 2005

**Document:** CDM-600 Open Network Satellite Modem (2.4 kbps – 20 Mbps)  
Installation and Operation Manual  
Revision 7, dated February 9, 2005

**Part Number:** MN/CDM600.EA7

**Collating Instructions:** Attach this page to page 16-13

### **Comments:**

The following changes affects the values shown on page 6-9 and 16-13.

### **Change Specifics:**

#### **Change to AUPC Target Eb/No Parameter**

Since Revision 7 of the CDM-600 Manual was published, the range of the value of target Eb/No has been increased. Effective in firmware version 2.1.1 and subsequent:

- Previously the maximum value was 9.9 dB
- New maximum value is 14.9 dB.

This affects the front panel and the remote control, refer to the remote control command table for more detail.

AUPC Parameters	APP=	6 bytes	<p>Command or Query.          Defines AUPC operating parameters. Has the form abc.cd, where:</p> <p>a=Defines action on max. power condition.          (0=do nothing, 1=generate Tx alarm)</p> <p>b=Defines action on remote demod unlock.          (0=go to nominal power, 1=go to max power)</p> <p><b>c.c=target Eb/No value, for remote demod, from 0.0 to 14.9 dB, where numbers above 9.9 use hex representation for the 1 st character, ie 14.9 is coded as E.9.</b></p> <p>d =Max increase in Tx Power permitted, from 0.0 to 9.0 dB</p> <p>Example: APP=015.67 (Sets no alarm, max power, 5.6 dB target Eb/No and 7 dB max power increase.</p>	APP= APP? APP* APP#	APP?	APP=abc.cd (see description of arguments)
-----------------	------	---------	---	------------------------------	------	--





# Errata B

## Comtech EF Data Documentation Update

**Subject:** Revised Miscellaneous Table

**Date:** April 18, 2006

**Document:** CDM-600 Open Network Satellite Modem (2.4 kbps – 20 Mbps)  
Installation and Operation Manual  
Revision 7, dated February 9, 2005

**Part Number:** MN/CDM600.EB7

**Collating Instructions:** Attach this page to page 15-9

**Comments:**

The following changes affects the values shown on page 15-9.

**Change Specifics:**

**15.2 Miscellaneous**

<b>Front panel</b>	Tactile keypad, 6 keys (Up/Down, Left/Right, Enter/Clear) Vacuum Fluorescent Display (blue) - 2 lines of 40 characters
<b>Loopbacks</b>	Internal IF loopback, RF loopback, digital loopback, and inward/outward loopback
<b>Fault relays</b>	Hardware fault, Rx and Tx Traffic Alarms, Open Network Backward Alarms <b>Type: Form C Contacts. Rating: Less than ± 15 volts up to 1 Amp</b>
<b>M&amp;C Interface</b>	EIA-232 and EIA-485 (addressable multidrop, 2-wire or 4-wire)
<b>M&amp;C Software</b>	SATMAC or CMCS software for control of local and distant units
<b>Dimensions</b>	1U high, 12 inches (305 mm) deep
<b>Weight</b>	10 lbs (4.5 kgs) max
<b>AC consumption</b>	25 watts (typical) <b>55 watts (maximum)</b>
<b>Operating voltage</b>	100 - 240 volts AC, +6%/-10% - autosensing (total absolute max. range is 90 - 254 volts AC)
<b>Operating temperature</b>	0 to 50°C (32 to 122°F)



# Errata C

## *Comtech EF Data Documentation Update*

**Subject:** Chapter Title

**Date:** July 12, 2006

**Document:** CDM-600 Open Network Satellite Modem (2.4 kbps – 20 Mbps)  
Installation and Operation Manual  
Revision 7, dated February 9, 2005

**Part Number:** MN/CDM600.EC7

**Collating Instructions:** Attach this page to page 15-3

### **Comments:**

The following changes affects odd numbers pages.

### **Change Specifics:**

CDM-600 Satellite Modem	Revision 7
<b>Summary of Specifications</b>	MN/CDM600.IOM



# Errata D

## Comtech EF Data Documentation Update

**Subject:** Changed Input Power Range

**Date:** July 18, 2006

**Document:** CDM-570/570L Satellite Modem with Optional IP Module, Installation and Operation Manual, Rev. 4, dated April 12, 2006

**Part Number:** MN/CDM-570L.ED4

**Collating Instructions:** Attach this page to page 12-3

### Comments:

Highlighted Input Power Range changes are as follows:

### Change Specifics:

#### 12.2 Demodulator

Data rate range, operating modes, de-scrambling, input impedance/return loss etc., as per Modulator

<b>Input power range</b>	<b>CDM-570 Desired Carrier:</b> -30 to -60 dBm. +35 dBc maximum composite, up to -5 dBm, absolute max.  <b>CDM-570L Desired Carrier:</b> $-130 + 10 \log(\text{Symbol Rate})$ to $-90 + 10 \log(\text{Symbol Rate})$ . <b>+40 dBc maximum composite, up to -10 dBm, absolute max.</b>
--------------------------	---



# Errata E

## Comtech EF Data Documentation Update

**Subject:** Changed Figure 7-5, TPC Curve for Rate 7/8

**Date:** July 27, 2006

**Document:** CDM-570/570L Satellite Modem with Optional IP Module, Installation and Operation Manual, Rev. 4, dated April 12, 2006

**Part Number:** MN/CDM-570L.EE4

**Collating Instructions:** Attach this page to page 7-14

**Comments:**

Chnaged slope of curves for TPC 7/8 for Figure 7-5. The following table highlights the changes to the BER curve.

**Change Specifics:**

TURBO PRODUCT CODEC Rate 7/8 QPSK Rate 7/8 8-PSK Rate 7/8 16-QAM BER (With two adjacent carriers, each 7 dB higher than the desired carrier)	For:  <b>BER=10<sup>-5</sup></b>  <b>BER=10<sup>-8</sup></b>	Rate 7/8 (Q, OQ) Guaranteed Eb/No: (typical value in parentheses)  <b>4.3 dB (4.0 dB)</b>	Rate 7/8 (8-PSK) Guaranteed Eb/No: (typical value in parentheses)  <b>7.0 dB (6.6 dB)</b>	Rate 7/8 (16-QAM) Guaranteed Eb/No: (typical value in parentheses)  <b>8.1 dB (7.7 dB)</b>
		<b>4.5 dB (4.2 dB)</b>	<b>7.2 dB (6.8 dB)</b>	<b>8.3 dB (7.9 dB)</b>

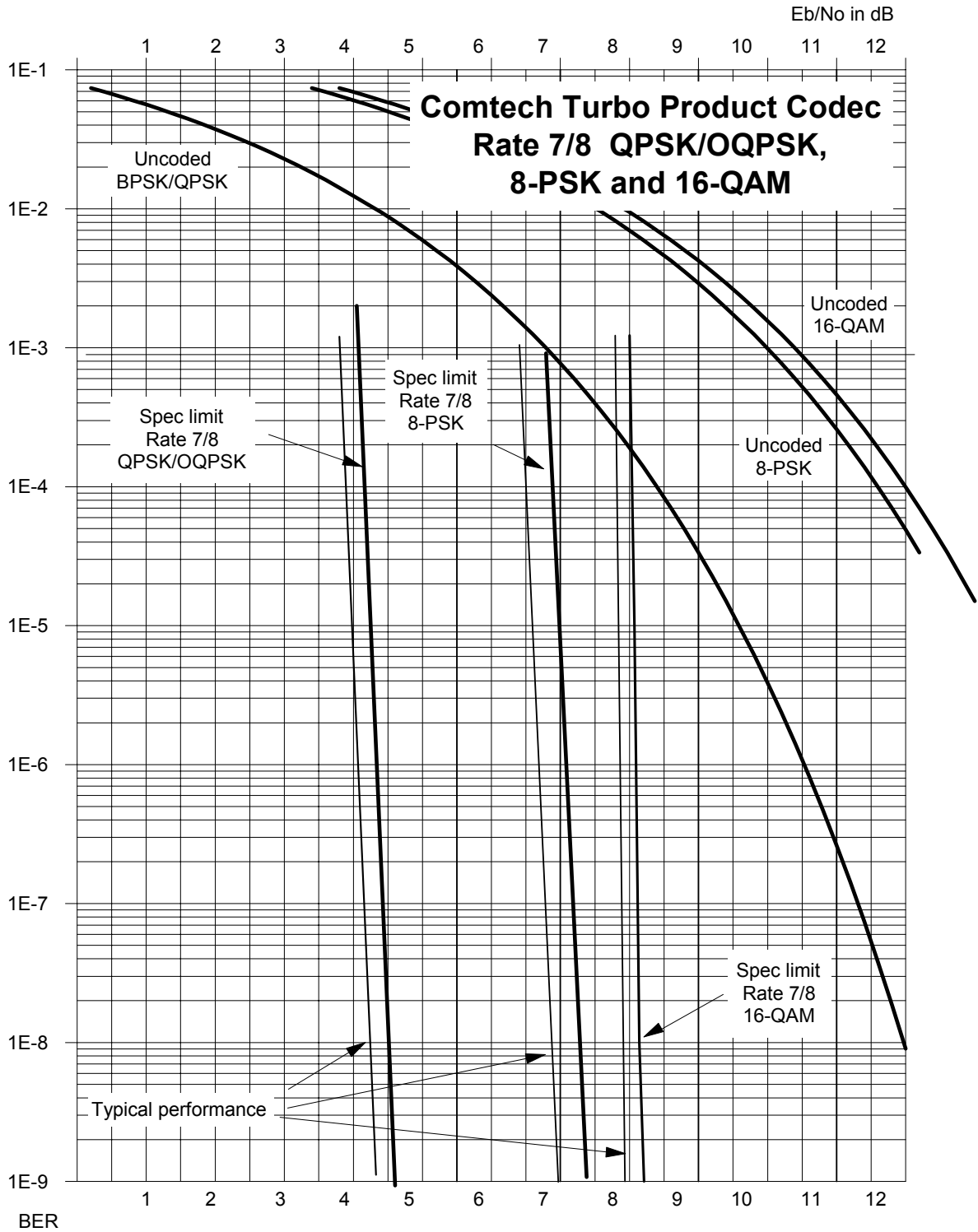

**Figure 7-5. Comtech EF Data Turbo Product Codec Rate 7/8 QPSK/OQPSK, 8-PSK AND 16-QAM**

# Errata F

## Comtech EF Data Documentation Update

**Subject:** Added Chart for AGC Voltage

**Date:** November 2, 2006

**Document:** CDM-600 Open Network Satellite Modem (2.4 kbps – 20 Mbps)  
Installation and Operation Manual  
Revision 7, dated February 9, 2005

**Part Number:** MN/CDM600.EF7

**Collating Instructions:** Attach this page to page 15-10

### Comments:

#### 15.9 AGC Voltage

**Note:** This is for reference only.

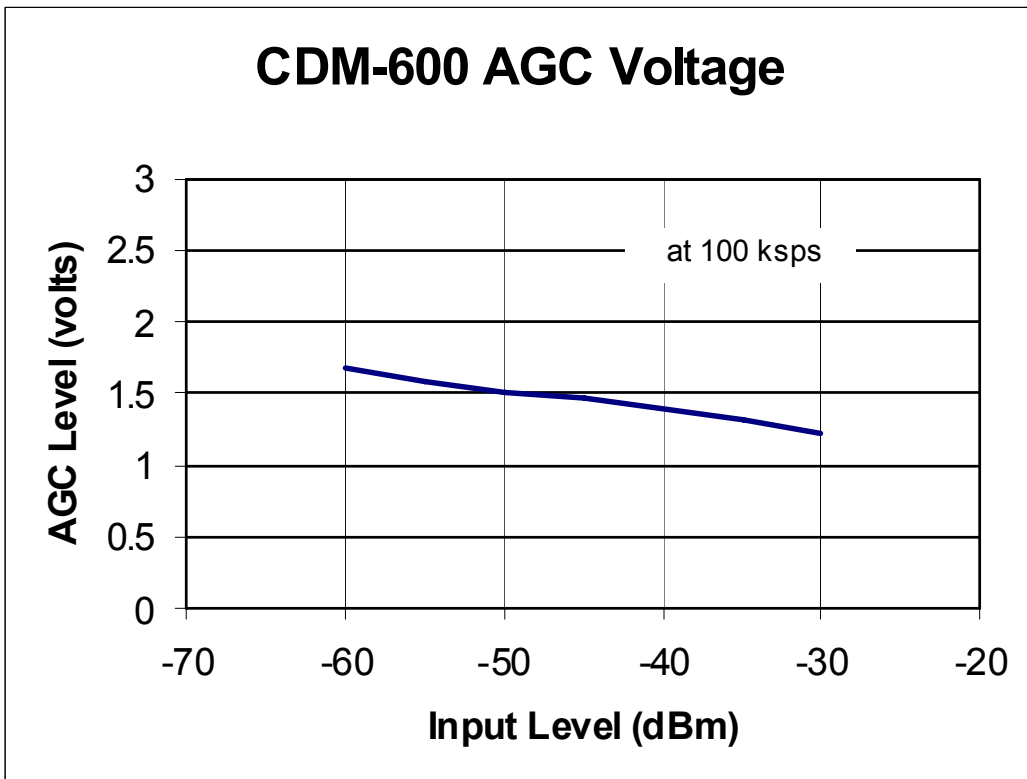







# Errata G

## *Comtech EF Data Documentation Update*

**Subject:** Revised Remote Command Index

**Date:** June 14, 2007

**Document:** CDM-600 Open Network Satellite Modem (2.4 kbps – 20 Mbps)  
Installation and Operation Manual  
Revision 7, dated February 9, 2005

**Part Number:** MN/CDM600.EG7

**Collating Instructions:** Attach this page to page 16-6

### **Comments:**

The revised index is presented on the following pages.

## A

Address, 16-9, 16-10, 16-18,  
16-25  
ADJ?, 16-27  
ADJ=, 16-27  
Alarm, 16-14, 16-18, 16-20,  
16-22, 16-23, 16-28, 16-39  
APP?, 16-12  
APP=, 16-12  
AUP?, 16-12  
AUP=, 16-12  
AUPC, 16-11, 16-12, 16-13,  
16-18, 16-20, 16-39

## B

Basic Protocol, 16-8  
BFS?, 16-35

## C

CAE=, 16-34  
CAS=, 16-33  
CID?, 16-29  
CID=, 16-29  
CLD=, 16-31  
CST=, 16-31  
CTD?, 16-28  
CTD=, 16-28

## D

D&I++, 16-8, 16-14, 16-16,  
16-20, 16-23  
DAY?, 16-31  
DAY=, 16-31  
DNI?, 16-40  
DNI?n, 16-40  
DNI=, 16-40  
DTS?, 16-41  
DTS=, 16-41  
DTY?, 16-14  
DTY=, 16-14

## E

EBA?, 16-22  
EBA=, 16-22  
EBN?, 16-35  
EFM?, 16-25  
EFM=, 16-25

EFR?, 16-27  
EFR=, 16-27  
EIA-232, 16-7, 16-8, 16-10  
EIA-485, 16-7, 16-8, 16-9,  
16-10  
EID?, 16-38  
End Of Packet, 16-13  
ESA?, 16-25  
ESA=, 16-25  
ESC?, 16-25  
ESC=, 16-25  
External Clock, 16-13

## F

FCS?, 16-37  
FLT?, 16-34, 16-39  
FSW=, 16-43

## I

IEP=, 16-35  
Instruction Code, 16-10, 16-  
11, 16-18, 16-20, 16-22  
Instruction Code Qualifier, 16-  
11  
IRD?, 16-22  
IRD=, 16-22  
ISP=, 16-33  
ITD?, 16-13  
ITD=, 16-13  
ITS?, 16-41  
ITS=, 16-41  
ITY?, 16-23  
ITY=, 16-23

## L

Loop-Timed, 16-13  
LRS?, 16-36  
LRS=, 16-36

## M

Message Arguments, 16-12  
MGC?, 16-30  
MGC?n, 16-30  
MGC=, 16-30  
MSK?, 16-28  
MSK=, 16-28

## N

NUE?, 16-33  
NUS?, 16-32

## O

ODU?, 16-29  
ODU=, 16-29

## P

Packet Structure, 16-9  
PLI?, 16-13

## R

RBA?, 16-24  
RBA=, 16-24  
RBS?, 16-23  
RBS=, 16-23  
RCB=, 16-31  
RCK?, 16-22  
RCK=, 16-22  
RCR?, 16-18  
RCR=, 16-18  
RDR?, 16-19  
RDR=, 16-19  
RDS?, 16-21  
RDS=, 16-21  
REB?, 16-13  
RED?, 16-36  
REF?, 16-20  
REF=, 16-20  
RET?, 16-24  
RET=, 16-24  
RFM?, 16-16  
RFM=, 16-16  
RFO?, 16-35  
RFQ?, 16-15  
RFQ=, 16-15  
RFT?, 16-17  
RFT=, 16-17  
RIP?, 16-24  
RIP=, 16-24  
RIT?, 16-16  
RIT=, 16-16  
RMD?, 16-17  
RMD=, 16-17  
RNE?, 16-34, 16-35  
RNS?, 16-33  
RRS?, 16-20

RRS=, 16-20  
 RSI?, 16-20  
 RSI=, 16-20  
 RSL?, 16-35  
 RSW?, 16-22  
 RSW=, 16-10, 16-22  
 RTC, 16-24, 16-30, 16-31,  
 16-32  
 RTC=, 16-24  
 RTE?, 16-23  
 RTE=, 16-23  
 RVL?, 16-23  
 RVL=, 16-23

**S**

SCP?, 16-26  
 SCP=, 16-26  
 Sequential, 16-17  
 SNO?, 16-36  
 SNO=, 16-36  
 SSI?, 16-32  
 SSI=, 16-32  
 Start Of Packet, 16-10  
 SWR?, 16-36

**T**

TBA?, 16-14  
 TBA=, 16-14  
 TCK?, 16-13  
 TCK=, 16-13  
 TCR?, 16-10  
 TCR=, 16-9, 16-10  
 TDR?, 16-10  
 TDR=, 16-10  
 TET?, 16-15  
 TET=, 16-15  
 TFM?, 16-8  
 TFM=, 16-8  
 TFQ?, 16-11, 16-12, 16-9  
 TFQ=, 16-9, 16-11, 16-12,  
 16-9  
 TFT?, 16-9  
 TFT=, 16-9  
 TIM?, 16-32  
 TIM=, 16-32  
 TIP?, 16-15  
 TIP=, 16-15  
 TIT?, 16-9  
 TIT=, 16-9

TMD?, 16-9  
 TMD=, 16-9  
 TMP?, 16-37  
 TPL?, 16-11  
 TPL=, 16-11  
 TRS?, 16-11  
 TRS=, 16-11  
 TSC?, 16-11  
 TSC=, 16-11  
 TSI?, 16-11  
 TSI=, 16-11  
 TST?, 16-28  
 TST=, 16-28  
 TTA?, 16-14  
 TTA=, 16-14  
 TTC?, 16-14  
 TTC=, 16-14  
 TVL?, 16-13  
 TVL=, 16-13  
 TXO?, 16-12  
 TXO=, 16-12

**V**

Viterbi, 16-17

**W**

WRM?, 16-27  
 WRM=, 16-27

This page intentionally left blank.



# ***CDM-600***

---

Open Network Satellite Modem (2.4 kbps – 20 Mbps)  
Installation and Operation Manual  
For Firmware Version 2.0.1 or higher  
(see ***New in this Release*** – Section 1.5)



Comtech EF Data is an ISO 9001  
Registered Company.

Part Number MN/CDM600.IOM  
Revision 7  
February 9, 2005



# Table of Contents

<b>PREFACE</b> .....	<b>XI</b>
<b>Customer Service</b> .....	<b>xi</b>
<b>About this Manual</b> .....	<b>xii</b>
<b>Conventions and References</b> .....	<b>xii</b>
<b>Electrical Safety</b> .....	<b>xiii</b>
<b>Telecommunications Terminal Equipment Directive</b> .....	<b>xiv</b>
<b>EMC (Electromagnetic Compatibility)</b> .....	<b>xv</b>
<b>Warranty Policy</b> .....	<b>xvi</b>
<b>CHAPTER 1. INTRODUCTION</b> .....	<b>1-1</b>
<b>1.1 Standard Features</b> .....	<b>1-2</b>
1.1.1 AUPC.....	1-2
1.1.2 Software – Flash Upgrading .....	1-3
1.1.3 Verification .....	1-3
1.1.4 Data Interfaces .....	1-3
<b>1.2 Major Assemblies</b> .....	<b>1-4</b>
<b>1.3 FAST Options and Hardware Options</b> .....	<b>1-4</b>
1.3.1 FAST Accessible Options.....	1-6
1.3.2 FAST System Theory.....	1-6
1.3.3 Implementation .....	1-6
1.3.4 Hardware Options .....	1-7
1.3.5 Supporting Hardware and Software.....	1-8
<b>1.4 Compatibility</b> .....	<b>1-8</b>
<b>1.5 New in this Release</b> .....	<b>1-9</b>
<b>CHAPTER 2. INSTALLATION</b> .....	<b>2-1</b>
<b>2.1 Unpacking</b> .....	<b>2-1</b>
<b>2.2 Mounting</b> .....	<b>2-2</b>
<b>2.3 Configuration</b> .....	<b>2-4</b>
<b>2.4 Select Internal IF Loop</b> .....	<b>2-4</b>

<b>2.5</b>	<b>Connect External Cables</b> .....	<b>2-4</b>
<b>CHAPTER 3. FUNCTIONAL DESCRIPTION</b> ..... <b>3-1</b>		
<b>CHAPTER 4. PHYSICAL DESCRIPTION</b> ..... <b>4-1</b>		
<b>4.1</b>	<b>Introduction</b> .....	<b>4-1</b>
<b>4.2</b>	<b>Front Panel</b> .....	<b>4-1</b>
<b>4.3</b>	<b>Rear Panel</b> .....	<b>4-2</b>
4.3.1	IEC Line Input Connector.....	4-2
4.3.2	Rx and Tx IF Connectors (J1 and J2) .....	4-3
4.3.3	Overhead Data Connector (P3A).....	4-3
4.3.4	Data Interface Connector (P3B).....	4-3
4.3.5	External Reference Connector (J9).....	4-3
4.3.6	Audio Connector (P4A).....	4-3
4.3.7	Remote Control connector (P4B).....	4-4
4.3.8	IDR Alarm connector (P5A).....	4-4
4.3.9	Form C Traffic Alarm Connector (P5B).....	4-4
4.3.10	Auxiliary Serial Connector (P6) .....	4-4
4.3.11	Balanced G.703 Interface Connector (P7) .....	4-4
4.3.12	IDI, DDO Connectors (J10A and J11A).....	4-5
4.3.13	Unbalanced G.703 Tx/Rx (J10B and J11B).....	4-5
4.3.14	External Frequency Reference Connector (J12) This is an SMA female connector. It is an optional connector used to permit the connection of a high-stability external reference signal. ....	4-5
<b>4.4</b>	<b>Dimensional Envelope</b> .....	<b>4-6</b>
<b>CHAPTER 5. CONNECTOR PINOUTS</b> ..... <b>5-1</b>		
<b>5.1</b>	<b>Connector Overview</b> .....	<b>5-1</b>
<b>5.2</b>	<b>BNC Connectors</b> .....	<b>5-2</b>
<b>5.3</b>	<b>Overhead Interface Connector (P3A)</b> .....	<b>5-2</b>
<b>5.4</b>	<b>Data Interface Connector (P3B)</b> .....	<b>5-3</b>
<b>5.5</b>	<b>Audio Interface Connector (P4A)</b> .....	<b>5-4</b>
<b>5.6</b>	<b>Remote Control Interface Connector (P4B)</b> .....	<b>5-4</b>
<b>5.7</b>	<b>IDR Backward Alarms Connector (P5A)</b> .....	<b>5-5</b>
<b>5.8</b>	<b>Unit Alarms (P5B)</b> .....	<b>5-5</b>
<b>5.9</b>	<b>Auxiliary Serial Connector (P6)</b> .....	<b>5-6</b>



<b>5.10</b>	<b>Balanced G.703 Interface Connector (P7)</b> .....	<b>5-6</b>
<b>5.11</b>	<b>AC Power Connector</b> .....	<b>5-7</b>
<b>5.12</b>	<b>Ground Connector</b> .....	<b>5-7</b>
<b>CHAPTER 6. FRONT PANEL OPERATION</b> .....		<b>6-1</b>
<b>6.1</b>	<b>Description</b> .....	<b>6-1</b>
<b>6.2</b>	<b>Opening Screen</b> .....	<b>6-5</b>
<b>6.3</b>	<b>Main Menu</b> .....	<b>6-5</b>
6.3.1	CONFIG .....	6-6
6.3.1.1	CONFIG: ALL .....	6-7
6.3.1.2	CONFIG: MODE .....	6-7
6.3.1.3	CONFIG: TX .....	6-8
6.3.1.4	CONFIG: RX .....	6-14
6.3.1.5	CONFIG: CLOCKS .....	6-19
6.3.1.6	CONFIG: DROP & INSERT .....	6-22
6.3.1.7	CONFIG: EDMAC .....	6-23
6.3.1.8	CONFIG: MISC .....	6-23
6.3.1.9	CONFIG: REMOTE CONTROL .....	6-26
6.3.1.10	CONFIG: MASK .....	6-27
6.3.1.11	CONFIG: IMPEDANCE .....	6-29
6.3.1.12	CONFIG: STATISTICS .....	6-29
6.3.2	TEST .....	6-30
6.3.3	INFORMATION .....	6-32
6.3.4	MONITOR .....	6-36
6.3.4.1	MONITOR: STORED EVENTS .....	6-37
6.3.4.2	MONITOR: STATISTICS .....	6-38
6.3.4.3	MONITOR: RX PARAMETERS .....	6-39
6.3.4.4	MONITOR: AUPC-PARAMS .....	6-39
6.3.5	STORE/LOAD .....	6-39
6.3.5.1	STORE/LOAD: OVERRIDE CONFIGURATION .....	6-40
6.3.6	UTILITIES .....	6-40
6.3.6.1	UTILITIES: SET-RTC .....	6-40
6.3.6.2	UTILITIES: BRIGHTNESS .....	6-40
6.3.6.3	UTILITIES: LAMP .....	6-41
6.3.6.4	UTILITIES: 1:1 MANUAL SWITCH .....	6-41
6.3.6.5	UTILITIES: CIRCUIT ID .....	6-41
6.3.7	ODU .....	6-42
6.3.8	FAST .....	6-42
6.3.8.1	FAST: SET .....	6-42
6.3.8.2	FAST: VIEW .....	6-42
<b>CHAPTER 7. FORWARD ERROR CORRECTION OPTIONS</b> .....		<b>7-1</b>
<b>7.1</b>	<b>Introduction</b> .....	<b>7-1</b>

<b>7.2</b>	<b>Viterbi .....</b>	<b>7-1</b>
<b>7.3</b>	<b>Sequential.....</b>	<b>7-2</b>
<b>7.4</b>	<b>Reed-Solomon Outer Codec.....</b>	<b>7-3</b>
<b>7.5</b>	<b>Trellis Coding (FAST Option) .....</b>	<b>7-5</b>
<b>7.6</b>	<b>Turbo Product Codec (Hardware Option) .....</b>	<b>7-6</b>
<b>7.7</b>	<b>TPC and Low Density Parity Check (LDPC) coding .....</b>	<b>7-6</b>
7.7.1	Introduction.....	7-6
7.7.2	LDPC versus TPC.....	7-7
7.7.3	End-to-End Processing Delay .....	7-9
<b>7.8</b>	<b>Uncoded Operation (No FEC) .....</b>	<b>7-11</b>
<b>CHAPTER 8. OFFSET QPSK OPERATION .....</b>		<b>8-1</b>
<b>CHAPTER 9. OPEN NETWORK OPERATIONS .....</b>		<b>9-1</b>
<b>9.1</b>	<b>Introduction.....</b>	<b>9-1</b>
<b>9.2</b>	<b>IBS.....</b>	<b>9-1</b>
9.2.1	IBS Clock/data recovery and De-jitter.....	9-2
9.2.2	IBS Framing.....	9-2
9.2.3	IBS Engineering Service Channel.....	9-2
9.2.4	IBS Scrambling.....	9-2
<b>9.3</b>	<b>Drop and Insert.....</b>	<b>9-2</b>
9.3.1	D&I Primary Data Interfaces .....	9-3
9.3.2	D&I Framing.....	9-3
<b>9.4</b>	<b>IDR.....</b>	<b>9-4</b>
9.4.1	IDR Primary Data Interfaces.....	9-5
9.4.2	IDR Engineering Service Channel.....	9-5
<b>CHAPTER 10. CLOCK MODES AND DROP AND INSERT (D&amp;I) .....</b>		<b>10-1</b>
<b>10.1</b>	<b>Transmit Clocking .....</b>	<b>10-1</b>
10.1.1	Internal Clock.....	10-1
10.1.2	Tx Terrestrial .....	10-2
10.1.3	Rx Loop-Timed, RX=TX.....	10-2
10.1.4	Rx Loop-Timed, RX<>TX (Asymmetric Loop Timing).....	10-2
10.1.5	External Clock .....	10-2
<b>10.2</b>	<b>Receive Clocking .....</b>	<b>10-3</b>
10.2.1	Buffer Disabled (RX Satellite).....	10-3
10.2.2	Buffer Enabled, TX=RX (TX Terrestrial or External Clock).....	10-3

10.2.3	Buffer Enabled, RX<>TX (TX Terrestrial or External Clock).....	10-3
<b>10.3</b>	<b>X.21 Notes .....</b>	<b>10-3</b>
<b>10.4</b>	<b>Drop and Insert .....</b>	<b>10-6</b>
<b>10.5</b>	<b>Frame Formats.....</b>	<b>10-7</b>
<b>10.6</b>	<b>Time Slot Selection.....</b>	<b>10-8</b>
<b>10.7</b>	<b>Drop and Insert Clocking.....</b>	<b>10-9</b>
<b>10.8</b>	<b>Rx Buffer Clock = Insert (D&amp;I only) .....</b>	<b>10-10</b>
<b>10.9</b>	<b>Single-Source Multiple Modems.....</b>	<b>10-10</b>
<b>CHAPTER 11. EDMAC CHANNEL.....</b>		<b>11-1</b>
<b>11.1</b>	<b>Theory Of Operation .....</b>	<b>11-1</b>
<b>11.2</b>	<b>M&amp;C Connection .....</b>	<b>11-2</b>
<b>11.3</b>	<b>Setup Summary .....</b>	<b>11-3</b>
<b>11.4</b>	<b>Drop &amp; Insert ++.....</b>	<b>11-4</b>
<b>CHAPTER 12. AUTOMATIC UPLINK POWER CONTROL .....</b>		<b>12-1</b>
<b>12.1</b>	<b>Introduction.....</b>	<b>12-1</b>
<b>12.2</b>	<b>Setting AUPC Parameters.....</b>	<b>12-2</b>
12.2.1	Target Eb/No.....	12-2
12.2.2	Max Range .....	12-2
12.2.3	Alarm .....	12-3
12.2.4	Demod Unlock .....	12-3
<b>12.3</b>	<b>Compensation Rate.....</b>	<b>12-3</b>
<b>12.4</b>	<b>Monitoring.....</b>	<b>12-4</b>
<b>CHAPTER 13. ESC++ .....</b>		<b>13-1</b>
<b>13.1</b>	<b>Introduction.....</b>	<b>13-1</b>
<b>13.2</b>	<b>Overhead Details .....</b>	<b>13-1</b>
<b>13.3</b>	<b>Available Baud Rates.....</b>	<b>13-2</b>
<b>13.4</b>	<b>Configuration .....</b>	<b>13-2</b>

<b>13.5</b>	<b>Effect on Eb/No performance .....</b>	<b>13-2</b>
<b>CHAPTER 14.</b>	<b>FLASH UPGRADING.....</b>	<b>14-1</b>
<b>CHAPTER 15.</b>	<b>SUMMARY OF SPECIFICATIONS .....</b>	<b>15-1</b>
15.1	Modulator.....	15-1
15.2	Demodulator .....	15-3
15.3	Data Interfaces .....	15-6
15.4	Automatic Uplink Power Control .....	15-7
15.5	Framing Summary .....	15-7
15.6	Data Rate Ranges.....	15-8
<b>15.7</b>	<b>Miscellaneous.....</b>	<b>15-9</b>
15.8	Approvals.....	15-9
<b>CHAPTER 16.</b>	<b>REMOTE CONTROL.....</b>	<b>16-1</b>
<b>16.1</b>	<b>Introduction.....</b>	<b>16-1</b>
<b>16.2</b>	<b>EIA-485 .....</b>	<b>16-1</b>
<b>16.3</b>	<b>EIA-232 .....</b>	<b>16-2</b>
<b>16.4</b>	<b>Basic Protocol.....</b>	<b>16-2</b>
<b>16.5</b>	<b>Packet Structure.....</b>	<b>16-3</b>
16.5.1	Start Of Packet .....	16-3
16.5.2	Address .....	16-3
16.5.3	Instruction Code.....	16-4
16.5.4	Instruction Code Qualifier .....	16-4
16.5.5	Message Arguments.....	16-5
16.5.6	End Of Packet .....	16-5
<b>16.6</b>	<b>Alphabetical list of Remote Commands.....</b>	<b>16-6</b>
<b>APPENDIX A.</b>	<b>CABLE DRAWINGS.....</b>	<b>A-1</b>
<b>APPENDIX B.</b>	<b>EB/NO MEASUREMENT.....</b>	<b>B-1</b>
<b>APPENDIX C.</b>	<b>FAST ACTIVATION PROCEDURE.....</b>	<b>C-1</b>

<b>C.1</b>	<b>Introduction.....</b>	<b>C-1</b>
<b>C.2</b>	<b>Activation Procedure .....</b>	<b>C-1</b>
C.2.1	Serial Number .....	C-1
C.2.2	View currently installed features .....	C-2
C.2.3	Enter Access Codes.....	C-2
<b>APPENDIX D.</b>	<b>ODU OPERATION.....</b>	<b>D-1</b>
<b>D.1</b>	<b>Introduction.....</b>	<b>D-1</b>
<b>D.2</b>	<b>MENU TREES.....</b>	<b>D-2</b>
<b>INDEX.....</b>		<b>I-1</b>

## Tables

Table 5-1.	External Connections.....	5-1
Table 5-2.	BNC Connectors.....	5-2
Table 5-3.	Overhead Interface Connector Pin Assignments .....	5-2
Table 5-4.	Data Interface Connector Pin Assignments.....	5-3
Table 5-5.	Audio Interface Connector Pin Assignments.....	5-4
Table 5-6.	Remote Control Interface Connector Pin Assignments .....	5-4
Table 5-7.	IDR Alarm Interface Connector Pin Assignments.....	5-5
Table 5-8.	Alarm Interface Connector Pin Assignments.....	5-5
Table 5-9.	Auxiliary Serial Connector (USB Type B Socket).....	5-6
Table 5-10.	Balanced G.703 Interface Connector Pin Assignments .....	5-6
Table 6-1.	Front Panel LED Indicators.....	6-2
Table 7-1.	Viterbi Decoding Summary .....	7-2
Table 7-2.	Sequential Decoding Summary .....	7-3
Table 7-3.	Concatenated RS Coding Summary.....	7-4
Table 7-4.	8-PSK/TCM Coding Summary.....	7-5
Table 7-5.	Available TPC and LDPC Modes.....	7-8
Table 7-6.	Turbo Product Coding Processing Delay Comparison.....	7-9
Table 7-7.	TPC and LDPC Summary.....	7-11

# Figures

Figure 1-1. CDM-600 .....	1-1
Figure 2-1. Installation of the Optional Mounting Bracket, KT/6228-2 .....	2-3
Figure 3-1. CDM-600 Modem Block Diagram .....	3-2
Figure 4-1. Front Panel .....	4-1
Figure 4-2. Rear Panel .....	4-2
Figure 4-3. Dimensional Envelope .....	4-6
Figure 6-1. Front Panel View .....	6-1
Figure 6-2. Keypad .....	6-3
Figure 6-3. Menu Trees .....	6-4
Figure 6-4. Loopback Modes .....	6-31
Figure 7-1. Viterbi Decoding .....	7-13
Figure 7-2. Sequential Decoding 64 kbps .....	7-14
Figure 7-3. Sequential Decoding 1024 kbps .....	7-15
Figure 7-4. Sequential Decoding 2048 kbps .....	7-16
Figure 7-5. Viterbi with concatenated R-S Outer Code .....	7-17
Figure 7-6. Sequential with concatenated R-S Outer Code .....	7-18
Figure 7-7. 8-PSK/TCM Rate 2/3 with and without concatenated RS Outer Code .....	7-19
Figure 7-8. Comtech EF Data Turbo Product Codec Rate 3/4 QPSK/OQPSK, 8-PSK and 16-QAM ..	7-20
Figure 7-9. Comtech EF Data Turbo Product Codec Rate 7/8 QPSK/OQPSK, 8-PSK and 16-QAM ..	7-21
Figure 7-10. Rate 1/2 QPSK, Rate 0.95 QPSK and Rate 0.95 8-PSK .....	7-22
Figure 7-11. Rate 21/44 BPSK and Rate 5/16 BPSK Turbo .....	7-23
Figure 7-12. 16-QAM Viterbi, Rate 3/4 and Rate 7/8 with 220,200 RS Outer Code .....	7-24
Figure 7-13. Differential Encoding - No FEC, No Scrambling .....	7-25
Figure 7-14. LDPC, Rate 1/2, BPSK, (O)QPSK .....	7-26
Figure 7-15. LDPC, Rate 2/3, (O)QPSK/8-PSK/8-QAM .....	7-27
Figure 7-16. LDPC, Rate 3/4, (O)QPSK/8-QAM .....	7-28
Figure 7-17. LDPC, Rate 3/4, 8-PSK / 8-QAM .....	7-29
Figure 10-1 Tx Clock Modes .....	10-4
Figure 10-2 Rx Clock Modes .....	10-5
Figure 10-3 Supported T1 and E1 Framing formats .....	10-7
Figure 10-4 Drop and Insert Clocking .....	10-9
Figure 10-5. Single-Source Multiple Modems (Looming) .....	10-10
Figure 10-6. Single-Source Multiple Modems (Daisy Chain) .....	10-11

# Preface

---

## Customer Service

Contact the Comtech EF Data Customer Support Department for:

- Product support or training
- Information on upgrading or returning a product
- Reporting comments or suggestions concerning manuals

A Customer Support representative may be reached at:

Comtech EF Data  
Attention: Customer Support Department  
2114 West 7th Street  
Tempe, Arizona 85281 USA

480.333.2200 (Main Comtech EF Data Number)  
480.333.4357 (Customer Support Desk)  
480.333.2161 FAX

or, E-mail can be sent to the Customer Support Department at:  
[service@comtechefdata.com](mailto:service@comtechefdata.com)

Contact us via the web at [www.comtechefdata.com](http://www.comtechefdata.com).

To return a Comtech EF Data product (in-warranty or out-of-warranty) for repair or replacement:

- Request a Return Material Authorization (RMA) number from the Comtech EF Data Customer Support Department.
- Be prepared to supply the Customer Support representative with the model number, serial number, and a description of the problem.
- To ensure that the product is not damaged during shipping, pack the product in its original shipping carton/packaging.
- Ship the product back to Comtech EF Data. (Shipping charges should be prepaid.)

For more information regarding the warranty policies, see Warranty Policy, p. xiv.

---

## About this Manual

This manual provides installation and operation information for the Comtech EF Data CDM-600 satellite modem. This is a technical document intended for earth station engineers, technicians, and operators responsible for the operation and maintenance of the CDM-600.

---

## Conventions and References

### Metric Conversion

Metric conversion information is located on the inside back cover of this manual. This information is provided to assist the operator in cross-referencing English to Metric conversions.

### Cautions and Warnings



*Indicates information critical for proper equipment function.*



*WARNING indicates a potentially hazardous situation that, if not avoided, could result in death or serious injury.*

### Recommended Standard Designations

Recommended Standard (RS) designations are equivalent to the new designation of the Electronic Industries Association (EIA). Manufacturer has determined to use only one reference throughout the manual. However, there may be an instance on illustrations that either designator may be used.

### Reporting Comments or Suggestions Concerning this Manual

Comments and suggestions regarding the content and design of this manual will be appreciated. To submit comments, please contact the Comtech EF Data Technical Publications Department: [techpub@comtechefdata.com](mailto:techpub@comtechefdata.com).



---

## Electrical Safety

The CDM-600 Modem has been shown to comply with the following safety standard:

- EN 60950: Safety of Information Technology Equipment, including electrical business machines.

The equipment is rated for operation over the range 100 - 240 volts AC. It has a maximum power consumption of 40 watts, and draws a maximum of 400 mA.



The user should observe the following instructions:

## Fuses

The CDM-600 is fitted with two fuses - one each for line and neutral connections. These are contained within the body of the IEC power inlet connector, behind a small plastic flap.

- For 230 volt AC operation, use T0.75A, 20mm fuses.
- For 115 volt AC operation, use T1.25A fuses, 20mm fuses.

**FOR CONTINUED OPERATOR SAFETY, ALWAYS REPLACE THE FUSES WITH THE CORRECT TYPE AND RATING.**

## Environmental

The CDM-600 must not be operated in an environment where the unit is exposed to extremes of temperature outside the ambient range 0 to 50°C, precipitation, condensation, or humid atmospheres above 95% RH, altitudes (un-pressurised) greater than 2000 metres, excessive dust or vibration, flammable gases, corrosive or explosive atmospheres.

Operation in vehicles or other transportable installations that are equipped to provide a stable environment is permitted. If such vehicles do not provide a stable environment, safety of the equipment to EN60950 may not be guaranteed.





## Installation

The installation and connection to the line supply must be made in compliance to local or national wiring codes and regulations.

The CDM-600 is designed for connection to a power system that has separate ground, line and neutral conductors. The equipment is not designed for connection to power system that has no direct connection to ground.

The CDM-600 is shipped with a line inlet cable suitable for use in the country of operation. If it is necessary to replace this cable, ensure the replacement has an equivalent specification. Examples of acceptable ratings for the cable include HAR, BASEC and HOXXX-X. Examples of acceptable connector ratings include VDE, NF-USE, UL, CSA, OVE, CEPEC, NEMKO, DEMKO, BS1636A, BSI, SETI, IMQ, KEMA-KEUR and SEV.

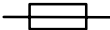
International Symbols:

Symbol	Definition		Symbol	Definition
	Alternating Current			Protective Earth
	Fuse			Chassis Ground

---

## Telecommunications Terminal Equipment Directive

In accordance with the Telecommunications Terminal Equipment Directive 91/263/EEC, this equipment should not be directly connected to the Public Telecommunications Network.

---

## EMC (Electromagnetic Compatibility)

In accordance with European Directive 89/336/EEC, the CDM-600 Modem has been shown, by independent testing, to comply with the following standards:

Emissions: EN 55022 Class B - Limits and methods of measurement of radio interference characteristics of Information Technology Equipment.

(Also tested to FCC Part 15 Class B)

Immunity: EN 50082 Part 1 - Generic immunity standard, Part 1: Domestic, commercial and light industrial environment.

Additionally, the CDM-600 has been shown to comply with the following standards:

EN 61000-3-2	Harmonic Currents Emission
EN 61000-3-3	Voltage Fluctuations and Flicker
EN 61000-4-2	ESD Immunity
EN 61000-4-4	EFT Burst Immunity
EN 61000-4-5	Surge Immunity
EN 61000-4-6	RF Conducted Immunity
EN 61000-4-8	Power frequency Magnetic Field Immunity
EN 61000-4-9	Pulse Magnetic Field Immunity
EN 61000-4-11	Voltage Dips, Interruptions, and Variations Immunity
EN 61000-4-13	Immunity to Harmonics



In order that the Modem continues to comply with these standards, observe the following instructions:

- Connections to the transmit and receive IF ports (BNC female connectors) should be made using a good quality coaxial cable - for example RG58/U (50Ω or RG59/U (75Ω).
- All 'D' type connectors attached to the rear panel must have back-shells that provide continuous metallic shielding. Cable with a continuous outer shield (either foil or braid, or both) must be used, and the shield must be bonded to the back-shell.
- The equipment must be operated with its cover on at all times. If it becomes necessary to remove the cover, the user should ensure that the cover is correctly re-fitted before normal operation commences.

---

## Warranty Policy

This Comtech EF Data product is warranted against defects in material and workmanship for a period of 2 years from the date of shipment. During the warranty period, Comtech EF Data will, at its option, repair or replace products that prove to be defective.

For equipment under warranty, the customer is responsible for freight to Comtech EF Data and all related custom, taxes, tariffs, insurance, etc. Comtech EF Data is responsible for the freight charges **only** for return of the equipment from the factory to the customer. Comtech EF Data will return the equipment by the same method (i.e., Air, Express, Surface) as the equipment was sent to Comtech EF Data.

## Limitations of Warranty

The foregoing warranty shall not apply to defects resulting from improper installation or maintenance, abuse, unauthorized modification, or operation outside of environmental specifications for the product, or, for damages that occur due to improper repackaging of equipment for return to Comtech EF Data.

*No other warranty is expressed or implied. Comtech EF Data specifically disclaims the implied warranties of merchantability and fitness for particular purpose.*

## Exclusive Remedies

The remedies provided herein are the buyer's sole and exclusive remedies. Comtech EF Data shall not be liable for any direct, indirect, special, incidental, or consequential damages, whether based on contract, tort, or any other legal theory.

## Disclaimer

Comtech EF Data has reviewed this manual thoroughly in order that it will be an easy-to-use guide to your equipment. All statements, technical information, and recommendations in this manual and in any guides or related documents are believed reliable, but the accuracy and completeness thereof are not guaranteed or warranted, and they are not intended to be, nor should they be understood to be, representations or warranties concerning the products described. Further, Comtech EF Data reserves the right to make changes in the specifications of the products described in this manual at any time without notice and without obligation to notify any person of such changes.

If you have any questions regarding your equipment or the information in this manual, please contact the Comtech EF Data Customer Support Department.

# Chapter 1. INTRODUCTION

The CDM-600 (Figure 1-1) is an Open Network Satellite Modem, intended for both Intelsat and closed network applications.

- It is compliant with IESS-308/309/310/315 specifications, but also adds significant other features in closed network modes.
- It offers variable data rates from 2.4 to 20 Mbps, in BPSK, QPSK, Offset QPSK, 8-PSK, 8-QAM and 16-QAM modes. Viterbi, Sequential, concatenated Reed-Solomon (RS), Trellis Coded Modulation (TCM), Turbo Product Coding (TPC) and Low-density Parity Check Coding (LDPC) are provided as Forward Error Correction (FEC) options.
- A full range of interface types is built in (no plug in cards required) including all G.703 types, and Drop and Insert (both Open and Closed Network) operation are available.
- The IF frequency range simultaneously covers 52 - 88 MHz and 104 - 176 MHz. *(Units manufactured after February 2005 cover 50 - 90 MHz and 100 - 180 MHz. The opening screen shows **CDM-600 (E)** - meaning **Extended IF range.**)*
- The modem is compact, 1U high and 12 inches deep, and consumes only 25 watts (typical).
- It has a front panel VFD display and keypad for local configuration and control, although it can be fully remote-controlled.



Figure 1-1. CDM-600

---

## 1.1 Standard Features

The CDM-600 provides a wealth of standard features which go far beyond the basic requirements of the Intelsat specifications.

- Low rate variable data rates – 2.4 kbps to 5.0 Mbps
- Mid-rate variable data rates – 2.4 kbps to 10.0 Mbps
- High-rate variable data rates – 2.4 kbps to 20.0 Mbps
- **Embedded Distant-end Monitor and Control (EDMAC)** (see Note)
- Selectable 50 $\Omega$  / 75 $\Omega$  IF port impedance
- Asymmetric Loop Timing
- **Automatic Uplink Power Control (AUPC)**
- Software – Flash Upgrading
- Modulation Types –BPSK, QPSK, and OQPSK
- 1:1 and 1:10 redundancy switches

**Note:** In this mode, an additional 5% overhead is combined with the traffic data, (1.5% in Turbo BPSK modes, Turbo Rate 1/2 QPSK/OQPSK, and all data rates greater than 2 Mbps) which permits **Monitor & Control (M&C)** information to be added (transparently to the user), allowing access to the distant-end modem. This mode does not require any additional cabling at either the local or distant-end Modems - access to EDMAC is via the standard M&C control port. Full M&C is possible, and importantly, the on/off status of the carrier at the distant-end carrier can be controlled. In addition, for firmware version 1.5.0 and higher, the proprietary D&I++ framing mode is available. This combines **Drop & Insert (D&I)** operation with a similar EDMAC link and a 2.2% overhead.

### 1.1.1 AUPC

An important innovation in the CDM-600 is the addition of **Automatic Uplink Power Control (AUPC)**. This feature enables the modem to automatically adjust its output power to maintain the Eb/No of the remote end of the satellite link constant. This provides protection against rain fading, a particularly severe problem with Ku-band links.

To accomplish this, either the EDMAC or D&I++ framing types may be used, and the distant end modem constantly sends back information about the demodulator Eb/No using reserved bytes in the overhead structure. Using the Eb/No, the local modem then adjusts its output power, and hence, a closed-loop feedback system is created over the satellite link.

A benefit of this feature is that whenever EDMAC or D&I++ with AUPC operation is selected, the remote demodulator's Eb/No can be viewed from the front panel display of the local modem. Note that EDMAC and D&I++ can be used in conjunction with either framing type.

## 1.1.2 Software – Flash Upgrading

The internal software is both powerful and flexible, permitting storage and retrieval of up to 10 different modem configurations. The modem uses ‘flash memory’ technology internally, and new firmware can be uploaded to the unit from an external PC. This simplifies software upgrading, and updates can now be sent via the Internet, e-mail, or on disk. The upgrade can be performed without opening the unit, by simply connecting the modem to the serial port of a computer. Refer to Chapter 13 Flash Upgrading for additional information.

## 1.1.3 Verification

The unit includes many test modes and loopbacks for rapid verification of the correct functioning of the unit. Of particular note is the IF loopback, which permits the user to perform a quick diagnostic test without having to disturb external cabling. During the loopback, all of the receive configuration parameters are temporarily changed to match those of the transmit side, and an internal RF switch connects the modulator output to the demodulator input. When normal operation is again selected, all of the previous values are restored.

## 1.1.4 Data Interfaces

The CDM-600 includes, as standard, a universal data interface that eliminates the need to exchange interface cards for different applications. The interfaces offered include:

- EIA-422 (EIA530) DCE (at rates up to 10 Mbps)
- X.21 DTE and DCE (at rates up to 10 Mbps)
- V.35 DCE (at rates up to 10 Mbps)
- Synchronous EIA-232 DCE (at rates up to 300 kbps)
- G.703 E1, balanced and unbalanced
- G.703 T1, balanced
- G.703 E2, balanced and unbalanced
- G.703 T2, balanced
- Serial LVDS (at rates up to 20 Mbps)
- Dual Audio, 600Ω (produces a single 64 kbps IBS data stream)
- HSSI (optional with CIC-20 interface converter)

---

## 1.2 Major Assemblies

Assembly	Description
AS/11229-1	Modem Card – Extended IF bandwidth - units manufactured after February 2005
AS/0424-1	Modem Card – Standard IF bandwidth - units manufactured before February 2005
AS/0463	Turbo Codec – low rate
AS/9436	Turbo Codec – high rate
PL/9076-1	Baseband Framing Card
PL/9122-1	Chassis
PL/10290	High Stability Reference (Part of KT/9585-1)
PL/10341-1	LDPC and Hight RateTurbo Codec
KT/9585-1	High Stability Reference ( <i>Consult factory for availability</i> )

---

## 1.3 FAST Options and Hardware Options

The CDM-600 is extremely flexible and powerful, and incorporates a large number of optional features. Some customers may not require all of these features, and therefore, in order to permit a lower initial cost, the modem may be purchased with only the desired features enabled. If, at a later date, a customer wishes to upgrade the functionality of a modem, Comtech EF Data provides a system known as FAST (**F**ully **A**ccessible **S**ystem **T**opology) which permits the purchase and installation of options through the use of special authorization codes, entered through the front panel, or remotely.

The base unit is equipped with Viterbi, Sequential and R-S codecs. It offers BPSK, QPSK, and OQPSK modulation types, and data rates up to 5.0 Mbps, with all interface types. It is, however, limited to Closed Network operation, but includes EDMAC and AUPC.



The following table shows what other options are available:

Option	Description and Comments	Option Installation method
Low Rate Variable	Data rate 2.4 kbps to 5.0 Mbps	BASE UNIT
Mid-Rate Variable	Data rate 2.4 kbps to 10.0 Mbps	FAST
Full Rate Variable	Data rate 2.4 kbps to 20.0 Mbps	FAST
8-PSK	Modulation Type (includes 8-QAM if the TPC / LDPC Codec is installed)	FAST
16-QAM	Modulation Type	FAST
High Rate IBS ESC	20 bits per Frame	FAST
IBS	Intelsat Business Services – IESS-309	FAST
IDR	Intermediate Data Rate – IESS-308	FAST
D&I	Drop and Insert (includes D&I++)	FAST
Dual Audio mode	2 x 32 kbps ADPCM Audio as primary data	FAST
Turbo Codec – Low Rate (1 <sup>st</sup> Gen)	5 Mbps TPC Codec	Hardware
Turbo Codec – High Rate (2 <sup>nd</sup> Gen)	20 Mbps TPC Codec	Hardware
TPC / LDPC Codec	20 Mbps TPC/LDPC Codec	Hardware
LDPC (Mid-Rate)	Data rate to 10 Mbps	FAST
LDPC (High-Rate)	Data rate to 20 Mbps	FAST
High Stability Reference	Internal/External 10 MHz reference - $2 \times 10^{-8}$	Hardware

***In order to operate in Turbo (TPC) Mode:***

To operate in the the Low Rate range (up to 5 Mbps), the modem requires any of the three Codec cards to be installed.

To operate in the Mid- or High-Rate ranges (up to 10 or 20 Mbps), the modem requires either the High Rate TPC Codec or the TPC / LDPC Codec to be installed.

***In order to operate in LDPC Mode:***

The unit will require the TPC/LDPC Codec to be installed. In the base configuration this will provide LDPC up to 5 Mbps. In order to operate at higher data rates, there are two additional FAST options available that permit operation up to 10 Mbps or 20 Mbps. Note that these are *in addition to* the base modem rate options.

***In order to operate in 8-QAM mode:***

The modem will require the TPC/LDPC Codec to be installed and have the 8-PSK / 8-QAM FAST option enabled.

For example, if LDPC operation at 20 Mbps, 8-QAM mode is required, the modem must be configured with the following:

- TPC/LDPC Codec hardware option
- Full rate variable FAST option
- High-Rate LDPC FAST option
- 8-PSK /8-QAM FAST option

### **1.3.1 FAST Accessible Options**

Comtech EF Data's FAST system allows immediate implementation of different options through the user interface keypad. All FAST options are available through the basic platform unit.

### **1.3.2 FAST System Theory**

FAST is an enhancement feature available in Comtech EF Data products, enabling on-location upgrade of the operating feature set - in the rack - without removing a modem from the setup. When service requirements change, the operator can upgrade the topology of the modem to meet those requirements within minutes after confirmation by Comtech EF Data. This accelerated upgrade can be accomplished only because of FAST's extensive use of programmable devices incorporating Comtech EF Data-proprietary signal processing techniques. These techniques allow the use of a unique access code to enable configuration of the available hardware. The access code can be purchased at any time from Comtech EF Data. Once obtained, the access code is loaded into the unit through the front panel keyboard or the rear remote port.

With the exclusive FAST technology, operators have maximum flexibility for enabling functions as they are required. FAST allows an operator to order a modem precisely tailored for the initial application.

### **1.3.3 Implementation**

FAST is factory-implemented in the modem at the time of order. Hardware options for basic modems can be ordered and installed either at the factory or in the field. The operator can select options that can be activated easily in the field, depending on the current hardware configuration of the modem. The Activation Procedure is described in Appendix C.

### 1.3.4 Hardware Options

There are four hardware options available:

- 1) Low Rate (1<sup>st</sup> Generation) Turbo Product Codec - a plug-in daughter card (SIMM module). This is capable of data rates up to 5 Mbps, and code rates limited to Rate 5/16 (BPSK, Rate 21/44 (BPSK) and Rate 3/4 (QPSK, OQPSK, 8-PSK and 16-QAM).
- 2) High Rate (2<sup>st</sup> Generation) Turbo Product Codec - a plug-in daughter card (SIMM module). This is capable of data rates up to 20 Mbps, and adds Rate 7/8 and Rate 0.95 capability.
- 3) Combination Low-density Parity Check (LDPC) and TPC Codec - a plug-in daughter card (SIMM module). This is capable of data rates up to 20 Mbps, and provides Rate 1/2, Rate 2/3 and Rate 3/4 code rates across the range of modulation types.
- 4) Internal/External High Stability Reference that provides a frequency stability of  $2 \times 10^{-8}$ . This may be fitted in the factory at the time of order, or fitted in the field as an upgrade (provided the CDM-600 was manufactured after a certain date - consult the factory for further information).
  - \* The option provides an additional connector on the rear panel to permit the connection of a high-stability external reference signal, which in turn will phase-lock all of the internal frequency generation circuits of the CDM-600, including the IF synthesizers.
  - \* The new connector is an SMA female type, located at the extreme right of the rear panel (when looking at the rear panel). This connector accepts signals at 1, 2, 5, 10 or 20MHz, over the range -5 dBm to +15 dBm, and is matched for both 50 and 75  $\Omega$  systems. The frequency is selected from either the front panel, or over the remote control interface.
  - \* If the user selects external reference operation, the unit expects to see an appropriate signal at this connector. If the monitor circuit does not sense a signal at the connector, a Traffic Alarm is generated, and the High-Stability Internal Reference (stability of  $5 \times 10^{-8}$ ) is automatically substituted.
  - \* If the user selects Internal Reference, the user may then adjust the exact frequency of the reference using the front panel, or the remote control interface.
  - \* In External mode the High-Stability Internal/External Reference Module works by phase-locking the Internal Reference to the externally applied signal. If for some reason (perhaps an incorrect frequency being applied) the PLL circuit senses a loss of lock, a Unit Alarm is generated, and the TX carrier will be muted.
  - \* Because the High-Stability Internal Reference is comprised of an Ovenized Crystal Oscillator (OCXO) there is a warm up period associated with this scheme. The user

may select, either from the front panel, or via the remote control, to have the unit:

Power-up instantly (in which case the frequency of the unit will drift until the oven has reached its correct operating temperature),

**OR:**

Select a warm-up delay, where the unit will not become operational until the oven has reached a temperature close to stabilization value.

**Notes :**

\* The CDM-600 uses an intelligent algorithm that takes into account the internal temperature of the unit, and the amount of time it has been powered down. In this way, the unit does not wait for the full period (which can be as much as 200 seconds) if power is cycled over a short time.

\* If the warm-up feature has been activated, the time-out period can be instantly terminated by pressing the CLEAR key on the front panel.

### 1.3.5 Supporting Hardware and Software

For 1:1 applications the CDM-600 is supported by the CRS-150, a low-cost external switch. For Hub applications, the CDM-600 is supported by a low-cost 1:N switch, the CRS-300.

The CDM-600 is a companion product for the Comtech EF Data line of RF Transceivers. The Modem incorporates an FSK serial link that can be activated on the Receive IF port for the purpose of communicating with a Transceiver, if connected. In this manner, a user may monitor, configure, and control the Transceiver, using the front panel display and keypad of the Modem. The EDMAC channel may also be used to convey M&C data to a Transceiver at the distant end of a satellite link, if it is connected to a CDM-600.

The CDM-600 is supported by Comtech EF Data's **SatMac** software, a Windows™ based application that provides a 'point and click' interface for complete systems of Comtech equipment, comprising Modems, Transceivers, and Redundancy Switches. For more information, or to order a free demo disk, please contact the factory.

---

## 1.4 Compatibility

The CDM-600 is fully backwards-compatible with the Comtech EF Data CDM-500, CDM-550, and CDM-550T modems. Being an Open Network Modem, the CDM-600 is fully compatible with modems from other manufacturers that are compliant with the IESS-308/309/310/314 specifications. Note, however, that IESS-315 (VSAT Turbo) defines closed network operation, and this therefore requires modems from the *same manufacturer* at both ends of the link.

---

## 1.5 New in this Release

Revision 7 of this document includes information on the the following new features:

- \* Low-Density Parity Check (LDPC) Codec (available in Firmware Version 1.6.0 onwards). This is the latest form of Forward Error Correction, giving enhanced performance when compared to some TPC modes. This is a plug-in module that also includes all of the 2<sup>nd</sup> Generation TPC functionality. This new codec is supported in in Firmware Version 1.6.0 onwards. Please see Chapter 7 for more details.
- \* 8-QAM – a new modulation scheme included specifically to replace 8-PSK when LDPC is used. It is only available when the LDPC codec is installed, and is supported in Firmware Version 1.6.0 onwards. Please see Chapter 7 for more details.
- \* A higher-throughput ESC type, called ESC++ . This new mode permits an async ESC rate of up 38.4 kbaud at a user data rate of 512 kbps (up to 4.8 kbaud at 64 kbps), while simultaneously permitting AUPC operation. This naturally uses more overhead than previous modes, although the percentage overhead reduces significantly at higher data rates. This is now a standard feature in Firmware Version 2.0.1 onwards. Please see Chapter 13 for more details.
- \* Extended IF frequency range (50 - 90 MHz and 100 - 180 MHz) for modems manufactured after February 2005. A new modem card has been developed for this wider IF bandwidth, which replaces the previous design. CDM-600 modems fitted with this new card are identified in the opening screen as **CDM-600(E)**, where the ‘E’ refers to Extended IF range. In addition to the new card, the modem requires Firmware Version 2.0.1 or higher.
- \* A **Power-On, Carrier-Off (POCO)** feature has been added to the Factory Menu.
  - \* When this option is set to OFF, the CDM-600 will power-up with the Tx Carrier in the last known state. (For example, if the Tx Carrier was ON, and then the power is cycled, the Tx Carrier will be turned ON once more.)  
***NOTE THAT THIS IS THE DEFAULT OPERATING MODE OF THE CDM-600, AND IT IS RECOMMENDED THAT THE USER LEAVE THE UNIT CONFIGURED IN THIS WAY.***
  - \* When this option is set to ON, the CDM-600 will always power-up with the Tx Carrier in the OFF state. The user must then, either through the front panel, or the remote control port, turn the Carrier ON in order for the unit to transmit a carrier.

Consult the factory for details of how to access the Factory Menu.

This page is intentionally blank.

# Chapter 2. INSTALLATION

---

## 2.1 Unpacking

Inspect shipping containers for damage. If shipping containers are damaged, keep them until the contents of the shipment have been carefully inspected and checked for normal operation.

The modem and manual are packaged in pre-formed, reusable, cardboard cartons containing foam spacing for maximum shipping protection.



*Do not use any cutting tool that will extend more than 1 inch into the container. This can cause damage to the modem.*

Unpack the modem as follows:

1. Cut the tape at the top of the carton indicated by OPEN THIS END.
2. Remove the cardboard/foam space covering the modem.
3. Remove the modem, manual, and power cord from the carton.
4. Save the packing material for storage or reshipment purposes.
5. Inspect the equipment for any possible damage incurred during shipment.
6. Check the equipment against the packing list to ensure the shipment is correct.
7. Refer to the following sections for further installation instructions.

## 2.2 Mounting

If the CDM-600 is to be mounted in a rack, ensure that there is adequate clearance for ventilation, particularly at the sides. In rack systems where there is high heat dissipation, forced air cooling must be provided by top or bottom mounted fans or blowers. Under no circumstance should the highest internal rack temperature be allowed to exceed 50°C (122°F).



***The CDM-600 CANNOT have rack slides mounted to the side of the chassis*** - two cooling fans are mounted on the right-hand side of the unit. However, Comtech EF Data recommends that **an alternate** method of support within the rack be employed, such as rack shelves. If there is any doubt, please consult the Comtech EF Data Customer Support department.

### Optional rear-mounting installation bracket

Install optional installation bracket (Figure 2-1) using mounting kit, KT/6228-2.

#### Optional: Mounting Kit , KT/6228-2

Quantity	Part Number	Description
2	FP/6138-1	Bracket, Rear Support
4	HW/10-32x1/2RK	Bolt, #10 Rack
2	HW/10-32HEXNUT	Nut, #10 Hex
2	HW/10-32FLT	Washer, #10 Flat
2	HW/10-32X1/4 SHC	Screw, Socket 10-32 x 1/4inch

The tools required for this installation are a medium **Phillips™ screwdriver**, and a **5/32-inch SAE Allen™ Wrench**.

Refer to the following Figure, then install the Modem rear support brackets as follows:

- a) Install the rear support brackets onto the mounting rail of the rack. Fasten with the bracket bolts.
- b) Mount the modem into the equipment rack ensuring that the socket heads engage into the modem slots of the rear support brackets.
- c) Fasten the provided #10 socket head screws to the rear-side mounting slots on either side of the chassis modem and secure with #10 flat washers and #10 hex nuts.



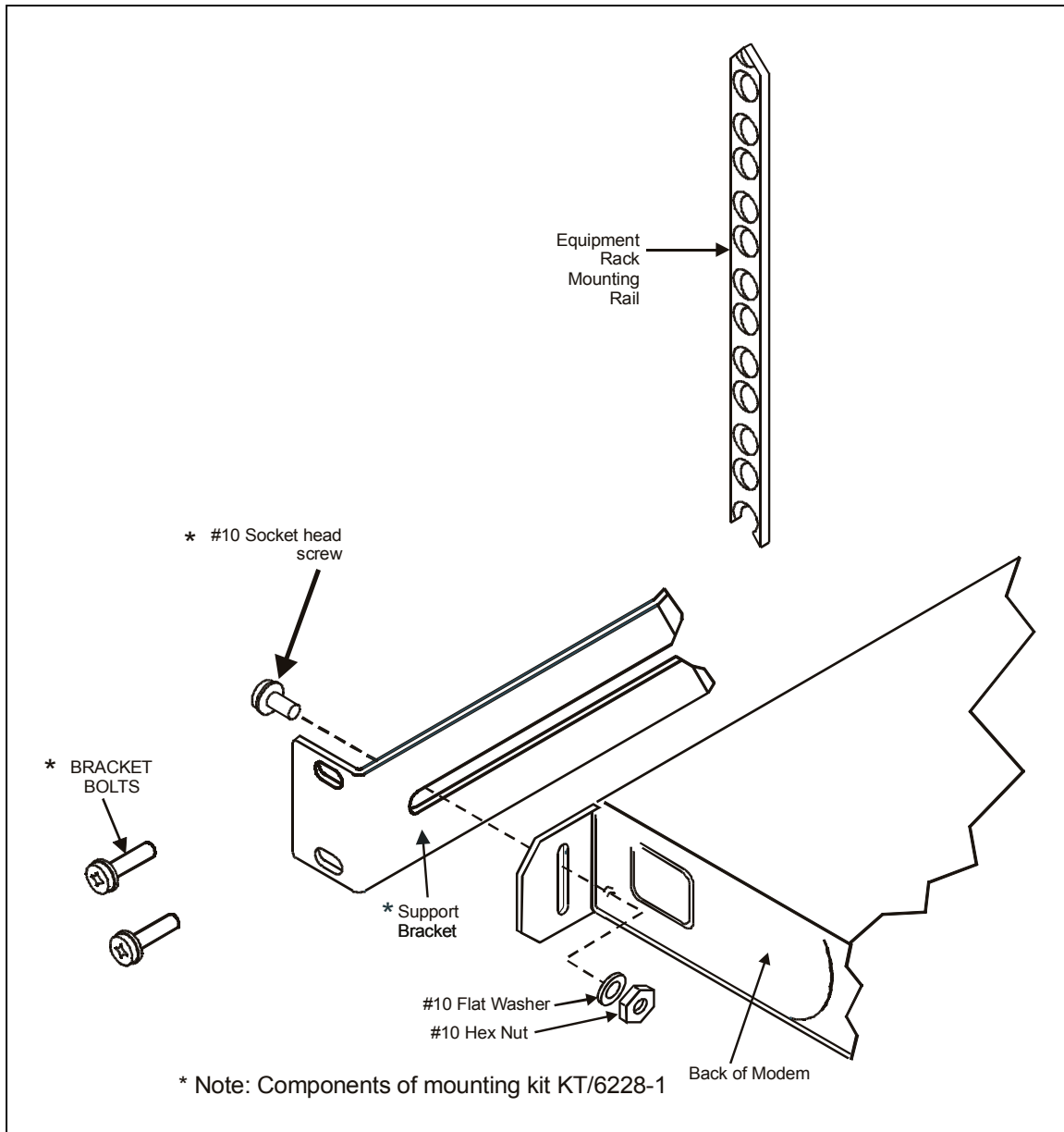

**Figure 2-1. Installation of the Optional Mounting Bracket, KT/6228-2**

---

## 2.3 Configuration

There are no internal jumpers to configure, no interface cards to install, and no other options to install. All configurations are carried out entirely in software. The unit should first be configured locally, using the front panel keypad and display. The unit will ship with a default 64 kbps, QPSK, Rate 1/2 configuration. Please refer to the 'FRONT PANEL OPERATION' section for details on how to fully configure the unit for the desired operating parameters.

**Note:** The auto-sensing AC power supply does not require any adjustments. Simply plug in the supplied line cord, and turn on the switch on the rear panel.

---

## 2.4 Select Internal IF Loop

Correct operation of the unit may be verified rapidly, without the need for externally connected equipment. From the top level menu, select TEST, then IF LOOP (refer to the 'FRONT PANEL OPERATION' section). The demod should synchronize, and the green RECEIVE TRAFFIC LED should illuminate. If the unit does not pass this test, call Comtech EF Data Customer Support department for assistance.

---

## 2.5 Connect External Cables

Having verified correct operation in IF loop, enter the desired configuration, and proceed to connect all external cables. If difficulties occur, please call the factory for assistance.

**Note:** That the modulator gives an output power level in the range 0 to -20 dBm, and the demodulator expects to see a signal in the range -30 to -60 dBm.

# Chapter 3. FUNCTIONAL DESCRIPTION

The CDM-600 has two fundamentally different types of interface - IF and data.

- The data interface is a bi-directional path which connects with the customer's equipment (assumed to be the DTE) and the modem (assumed to be the DCE).
- The IF interface provides a bi-directional link with the satellite via the uplink and downlink equipment.

Transmit data is received by the terrestrial interface where line receivers convert the clock and data signals to CMOS levels for further processing. A small FIFO follows the terrestrial interface to facilitate the various clocking and framing options. If framing is enabled, the transmit clock and data output from the FIFO pass through the framer, where the overhead data (IDR, IBS, D&I or EDMAC) is added to the main data. Otherwise, the clock and data are passed directly to the Forward Error Correction encoder. In the FEC encoder, the data is differentially encoded, scrambled, and then convolutionally encoded. Following the encoder, the data is fed to the transmit digital filters, which perform spectral shaping on the data signals. The resultant I and Q signals are then fed to the BPSK, QPSK/OQPSK, 8-PSK, 8-QAM, or 16-QAM modulator. The carrier is generated by a frequency synthesizer, and the I and Q signals directly modulate this carrier to produce an IF output signal.

The RX-IF signal is translated directly to baseband, using the carrier recovery VCO. This is a complex mix, resulting in the signal once more being split into an in-phase (I) and a quadrature (Q) component. An AGC circuit maintains the desired signal level constant over a broad range. Following this, the I and Q signals are sampled by high-speed (flash) A/D converters. All processing beyond this conversion is purely digital, comprising a Costas loop, that performs the functions of Nyquist filtering, carrier recovery, and symbol timing recovery. The resultant demodulated signal is fed, in soft decision form, to the selected FEC decoder (which can be Viterbi, Sequential, TCM, Reed-Solomon, Turbo, LDPC if installed). After decoding, the recovered clock and data pass to the de-framer (if IBS, IDR, D&I or EDMAC framing is enabled) where the overhead information is



# Chapter 4. PHYSICAL DESCRIPTION

---

## 4.1 Introduction

The CDM-600 is constructed as a 1U high rack-mount chassis, which can be free-standing. Rack handles at the front ease removal from and placement into a rack. Figure 4-1 shows the front panel of the modem.

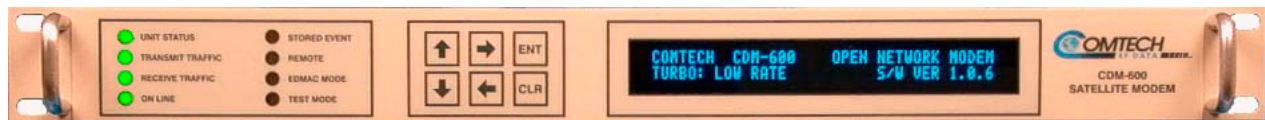

Figure 4-1. Front Panel

---

## 4.2 Front Panel

The front panel contains the Vacuum Fluorescent Display (VFD), keypad, and eight LED indicators. The user enters data via the keypad, and messages are displayed on the VFD. The LEDs indicate, in a summary fashion, the status of the unit.

The VFD is an active display showing 2 lines of 40 characters each. It produces a blue light with adjustable brightness. Viewing characteristics are superior to a Liquid Crystal Display (LCD), and do not suffer problems of viewing angle or contrast.

The keypad comprises six individual keyswitches, mounted directly behind a fully sealed membrane overlay. They have a positive 'click' action, which provides tactile feedback. These six switches are identified as [↑], [↓], [→], [←] arrows, ENTER and CLEAR. The functions of these keys are described in the 'Front Panel Operation' section.

There are 8 LEDs on the front panel. The behavior of these LEDs is also described in the 'Front Panel Operation' section.

## 4.3 Rear Panel



Figure 4-2. Rear Panel

External cables are attached to connectors on the rear panel of the CDM-600. These comprise:

Name	Ref Des	Connector Type	Function
Rx IF	J1	BNC	RF Input
Tx IF	J2	BNC	RF Output
Aux Serial	P6	He1402 3 pin header	Auxiliary Serial
Overhead	P3A	25-pin D (male)	Overhead Data
Data Interface	P3B	25-pin D (female)	Data Input/Output
External Reference	J9	BNC	Input
Audio	P4A	9-pin D (female)	Sound Input
Remote Control	P4B	9-pin D (male)	Remote Interface
IDR Alarm	P5A	15-pin D (female)	Alarm
Alarms	P5B	15-pin D (male)	FORM C Alarm
Balanced G.703	P7	15-pin D (female)	Balanced G.703 Data
IDI	J10A	BNC	Insert Data In
DDO	J11A	BNC	Drop Data Output
Rx Unbalanced	J10B	BNC	Receive G.703
Tx Unbalanced	J11B	BNC	Transmit G.703
External Frequency Ref	J12	SMA	External IF reference Input (Optional)

**Note:** The European EMC Directive (EN55022, EN50082-1) requires using properly shielded cables for DATA I/O. These cables must be double-shielded from end-to-end, ensuring a continuous ground shield.

### 4.3.1 IEC Line Input Connector

The IEC line input connector contains the ON/OFF switch for the unit. It is also fitted with two fuses - one each for line and neutral connections (or L1, L2, where appropriate). These are contained within the body of the connector, behind a small plastic flap.

- For 230 volt AC operation, use T0.75A, (slow-blow) 20mm fuses.
- For 115 volt AC operation, use T1.25A, (slow-blow) 20mm fuses.



For continued operator safety, always replace the fuses with the correct type and rating.

### 4.3.2 Rx and Tx IF Connectors (J1 and J2)

The IF port connectors are both a 50 $\Omega$  BNC female type. 75 $\Omega$  cable connectors (male) will have no problem mating with this 50 $\Omega$  type. The electrical impedance presented by these connectors is controlled internally by an RF-switching arrangement. This selection between 50 $\Omega$  and 75 $\Omega$  is controlled either via the front panel menus, or via the remote control bus.

### 4.3.3 Overhead Data Connector (P3A)

The Overhead data connector is a 25-pin 'D' type male (DB25-M). It is used for passing components of INTELSAT specified overhead frame structures. These include 64 kbps EIA-422 and 1/16 IBS overhead ESC at EIA-232. The IDR backward alarm inputs are found on this connector.

### 4.3.4 Data Interface Connector (P3B)

The Data connector is a 25-pin 'D' type female (DB25-F). This connector conforms to the EIA-530 pinout, which allows for connection of different electrical standards, including EIA-422, V.35, and EIA232. A shielded 25-pin 'D' type provides a very solid solution to EMC problems, unlike the sometimes used V.35 Winchester connector.



It is the responsibility of the user to provide the appropriate cables to connect to this EIA-530 connector.

### 4.3.5 External Reference Connector (J9)

This is a BNC female connector. It is used for operating the buffer with an external station reference. It requires an EIA-422 compatible level, so this unbalanced input should have a zero volt offset and a swing of at least  $\pm 2V$  into the 120  $\Omega$  termination provided.

### 4.3.6 Audio Connector (P4A)

The Audio connector is a 9-pin 'D' type female (DB9-F). It is used for the two 32 kbps ADPCM audio inputs and outputs (600  $\Omega$  transformer coupled, balanced signals). These can be used for both ESC voice circuits in IDR mode, or as the primary data (FAST option).

#### 4.3.7 Remote Control connector (P4B)

The Remote Control connector is a 9-pin 'D' type male (DB-9-M). Access is provide to remote control ports of the modem, both EIA-232 and EIA-485.

#### 4.3.8 IDR Alarm connector (P5A)

The Alarms connector is a 15-pin 'D' type female (DB15-F). Four Form C backward alarm outputs specified by INTELSAT are found on this connector.

#### 4.3.9 Form C Traffic Alarm Connector (P5B)

The Alarms connector is a 15-pin 'D' type male (DB15-M). This provides the user with access to the Form-C relay contacts, which indicate the fault status of the unit. These are typically connected to an external fault monitoring system, often found in satellite earth stations. In addition, the receive I and Q demodulator samples are provided on this connector. Connecting these signals to an oscilloscope in X, Y mode will provide the receive signal constellation diagram, which is a useful diagnostic aid. A pin is also provided which can mute the transmit carrier. This requires that the pin be shorted to ground, or a TTL 'low', or an RS232 'high' signal be applied. As an aid to antenna pointing, or for driving step-track equipment, an analog AGC signal is provided on Pin 2 of this connector.

#### 4.3.10 Auxiliary Serial Connector (P6)

This is an additional EIA-232 serial port, which is only used when the modem is part of a 1:1 pair. It uses a USB Type B connector.



***Although this port uses a USB connector, the signals are not USB compatible. Do NOT connect this port to the USB port of a PC, or other computing device.***

#### 4.3.11 Balanced G.703 Interface Connector (P7)

A 15-pin 'D' type female (DB15-F) for balanced operation at the G.703 data rates of T1 (1.544 Mbps), E1 (2.048 Mbps) or T2 (6.312 Mbps).



#### **4.3.12 IDI, DDO Connectors (J10A and J11A)**

Two additional female BNC  $75\Omega$  connectors for unbalanced operation at the G.703 data rate of E1 (2.048 Mbps). These are the Insert Data In (IDI) and Drop Data Out (DDO) port.

An alternative use for these ports is for sub-rate G.703 auxiliary operation on modems with hardware revision 2.0 or higher. This permits operation at the additional rates of 512 and 1024 kbps. In this mode, IDI serves as the TX terrestrial input port, and DDO as the output port.

#### **4.3.13 Unbalanced G.703 Tx/Rx (J10B and J11B)**

Two female BNC  $75\Omega$  connectors for unbalanced operation at the G.703 data rates of E1 (2.048 Mbps), T2 (6.312 Mbps), or E2 (8448 kbps).

#### **4.3.14 External Frequency Reference Connector (J12)**

This is an SMA female connector. It is an optional connector used to permit the connection of a high-stability external reference signal.

## 4.4 Dimensional Envelope

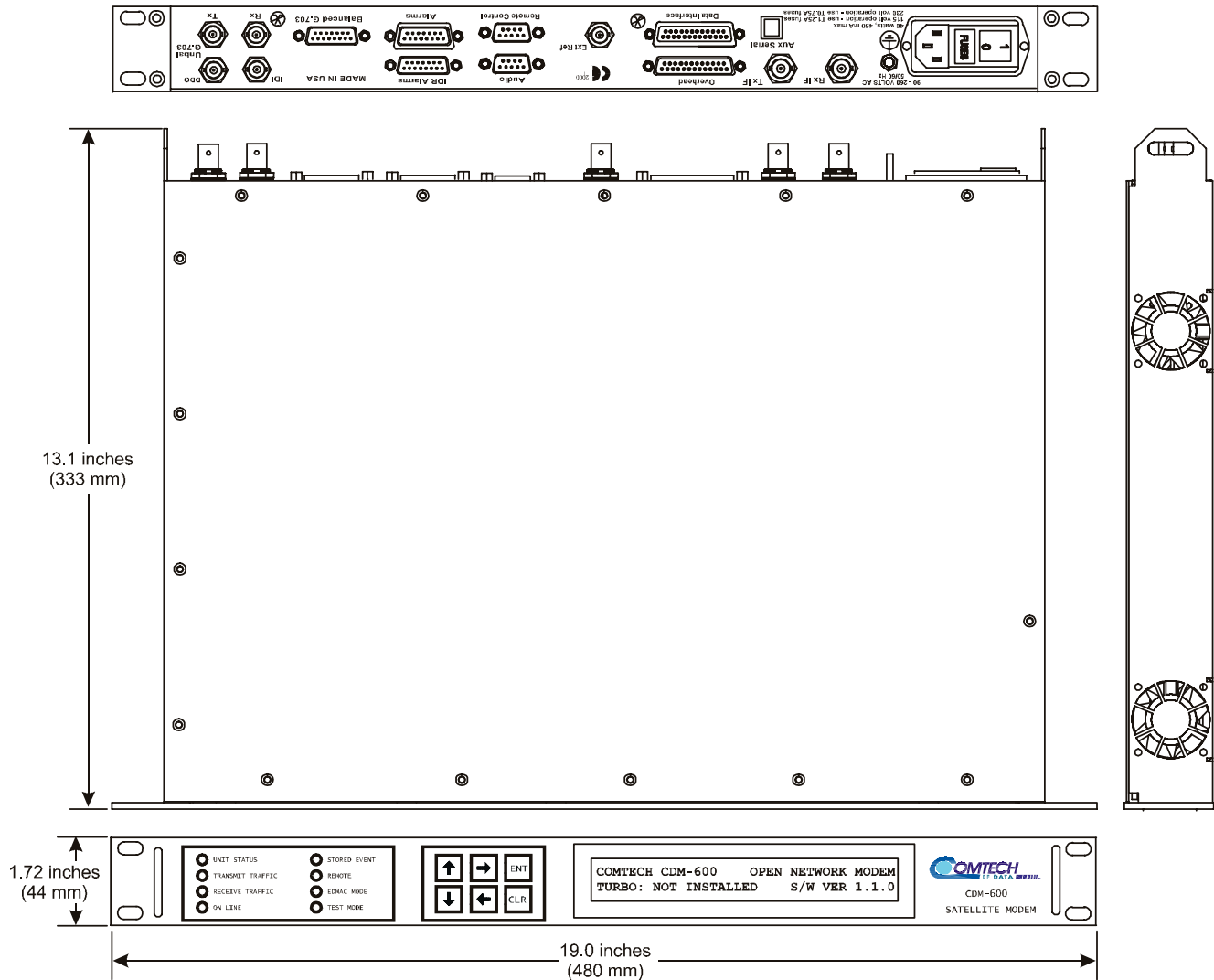

Figure 4-3. Dimensional Envelope

# Chapter 5. CONNECTOR PINOUTS

## 5.1 Connector Overview

The rear panel connectors (Figure 5-1) provide all necessary external connections between the modem and other equipment.



Figure 5-1. Rear Panel

Table 5-1. External Connections

Name	Ref	Connector Type	Function
RX IF	J1	BNC	RF Input
TX IF	J2	BNC	RF Output
Aux Serial	P6	USB Type B (female)	Auxiliary Serial
Overhead	P3A	25-pin D (male)	Overhead Data
Data Interface	P3B	25-pin D (female)	Data Input/Output
External Reference	J9	BNC	Input
Audio	P4A	9-pin D (female)	Audio Signal Input/Output
Remote Control	P4B	9-pin D (male)	Remote Interface
IDR Alarm	P5A	15-pin D (female)	Alarm
Alarms	P5B	15-pin D (male)	FORM C Alarms
Balanced G.703	P7	15-pin D (female)	Balanced G.703 Data
IDI	J10A	BNC	Insert Data In/Sub-rate Auxiliary Tx G.703 In
DDO	J11A	BNC	Drop Data Output/ Sub-rate Auxiliary Rx G.703 Out
RX Unbalanced	J10B	BNC	Receive G.703 (IDO)
TX Unbalanced	J11B	BNC	Transmit G.703 (DDI)
External Frequency Reference	J12	SMA	High-Stability External Reference (Optional)

Note: To maintain compliance with the European EMC Directive (EN55022, EN50082-1) properly shielded cables are required for all data I/O.

## 5.2 BNC Connectors

The BNC connectors are located on the rear panel of the modem. Refer to Table 5-2 for pin assignments.

**Table 5-2. BNC Connectors**

BNC Connector	Reference	Description	Direction
RX-IF	J1	RX-IF signals	In
TX-IF	J2	TX-IF signals	Out
EXT REF	J9	External Baseband Input	In
IDI	J10A	Insert Data Input	In
DDO	J11A	Drop Data Output	Out
RX (IDO)	J10B	RX G.703 (Unbalanced)	Out
TX (IDI)	J11B	TX G.703 (Unbalanced)	In

## 5.3 Overhead Interface Connector (P3A)

The overhead interface connector is a 25-pin male D interface located on the rear panel of the modem. Refer to Table 5-3 for pin assignments.

**Table 5-3. Overhead Interface Connector Pin Assignments**

Pin #	Signal Function	Signal Name	Direction
14	IDR 64 kbps ESC Tx Data +	TX-422DAT-B	In
2	IDR 64 kbps ESC Tx Data -	TX-422DAT-A	In
12	IDR 64 kHz ESC Tx Clock +	TX-422CLK-B	Out
15	IDR 64 kHz ESC Tx Clock -	TX-422CLK-A	Out
11	IDR 1 kHz Tx Octet Clock +	TX-OCT-B	Out
24	IDR 1 kHz Tx Octet Clock -	TX-OCT-A	Out
16	IDR 64 kbps ESC Rx Data +	RX-422DAT-B	Out
3	IDR 64 kbps ESC Rx Data -	RX-422DAT-A	Out
9	IDR 64 kHz ESC Rx Clock +	RX-422CLK-B	Out
17	IDR 64 kHz ESC Rx Clock -	RX-422CLK-A	Out
19	IDR 1 kHz Rx Octet Clock +	RX-OCT-B	Out
4	IDR 1 kHz Rx Octet Clock -	RX-OCT-A	Out
20	Balanced Ext.Baseband Clock +	EXT-CLK-B	In
23	Balanced Ext.Baseband Clock -	EXT-CLK-A	In
13	IBS/D&I ESC RS232 Tx Data	TX-232-DATA	In
22	IBS/D&I ESC RS232 Tx Clock	TX-232-CLK	Out
8	IBS/D&I ESC RS232 Rx Data	RX-232-DATA	Out
10	IBS/D&I ESC RS232 Rx Clock	RX-232-CLK	Out
5	IBS Tx High-Rate ESC Data	TX-ASYNC	In
6	IBS Rx High-Rate ESC Data	RX-ASYNC	Out
1	IDR Back Alarm 1 H/W input	BW-IN1	In
18	IDR Back Alarm 2 H/W input	BW-IN2	In
21	IDR Back Alarm 3 H/W input	BW-IN3	In
25	IDR Back Alarm 4 H/W input	BW-IN4	In
7	Signal Ground	Ground	-

## 5.4 Data Interface Connector (P3B)

The Data Interface connector, a 25-pin D type female, conducts data input and output signals to and from the modem, and connects to customer's terrestrial equipment, breakout panel, or protection switch. Refer to Table 5-4 for pin assignments.

**Table 5-4. Data Interface Connector Pin Assignments**

Pin #	Generic Signal description	Direction	EIA-422 EIA 530 LVDS	V.35	EIA-232	Circuit #
2	Transmit Data A	DTE to Modem	SD A	SD A	BA	103
14	Transmit Data B	DTE to Modem	SD B	SD B	-	103
24	Transmit Clock A	DTE to Modem	TT A	SCTE A	DA	113
11	Transmit Clock B	DTE to Modem	TT B	SCTE B	-	113
15	Internal Transmit Clock A	Modem to DTE	ST A	SCT A	DB	114
12	Internal Transmit Clock B	Modem to DTE	ST B	SCT B	-	114
3	Receive Data A	Modem to DTE	RD A	RD A	BB	104
16	Receive Data B	Modem to DTE	RD B	RD B	-	104
17	Receive Clock A	Modem to DTE	RT A	SCR A	DD	115
9	Receive Clock B	Modem to DTE	RT B	SCR B	-	115
8	Receiver Ready A	Modem to DTE	RR A	RLSD *	CF	109
10	Receiver Ready B	Modem to DTE	RR B	-	-	109
23	External Carrier Off (EIA-232 '1' or TTL 'low' )	DTE to Modem	-	-	-	-
7	Signal Ground	-	SG	SG	AB	102
1	Shield	-	Shield	FG	AN	101

**Notes:**

1. Receiver Ready is an EIA-232 -level control signal on a V.35 interface.
2. DO NOT connect signals to pins which are not shown - these pins are reserved for use by the redundancy system.
3. 'B' signal lines are not used for EIA-232 applications.
4. For X.21 operation, use the EIA-422 pins, but ignore Receive Clock if the Modem is DTE, and ignore Transmit clocks if the Modem is DCE.
5. For IDR operation using G.703, this primary interface becomes the 8 kbps EIA-422 overhead channel.

## 5.5 Audio Interface Connector (P4A)

The Audio interface connection is a 9-pin female D connector located on the rear panel of the modem. Refer to Table 5-5 for pin assignments.

**Table 5-5. Audio Interface Connector Pin Assignments**

Pin #	Signal Function	Direction
1	Tx Audio 1 +	In
6	Tx Audio 1 -	In
2	Rx Audio 1 +	Out
7	Rx Audio 1 -	Out
8	Tx Audio 2 +	In
4	Tx Audio 2 -	In
9	Rx Audio 2 +	Out
5	Rx Audio 2 -	Out
3	Common	

## 5.6 Remote Control Interface Connector (P4B)

The remote control interface connection is a 9-pin male connector located on the rear panel of the modem. Refer to Table 5-6 for pin assignments. The remote control port is intended for connection to an M&C computer, or terminal device. This interface is user selectable for either EIA-232 or EIA-485.

**Table 5-6. Remote Control Interface Connector Pin Assignments**

Pin #	Description	Direction
1	Ground	
2	EIA-232 Transmit Data	Out
3	EIA-232 Receive Data	In
4	Reserved - do not connect to this pin	
5	Ground	
6	EIA-485 Receive Data B *	In
7	EIA-485 Receive Data A *	In
8	EIA-485 Transmit Data B	Out
9	EIA-485 Transmit Data A	Out

\* Use for 2-wire EIA-485 operation

## 5.7 IDR Backward Alarms Connector (P5A)

The IDR Alarm interface connection is a 15-pin female connector located on the rear panel of the modem. Refer to Table 5-7 for pin assignments.

**Table 5-7. IDR Alarm Interface Connector Pin Assignments**

Pin #	Signal Function	Name
2 9 1	Backward Alarm 1 is active Backward Alarm 1 is not active	BA-1-NO BA-1-COM BA-1-NC
10	TBD	MON-A
4 11 3	Backward Alarm 2 is active Backward Alarm 2 is not active	BA-2-NO BA-2-COM BA-2-NC
6 13 5	Backward Alarm 3 is active Backward Alarm 3 is not active	BA-3-NO BA-3-COM BA-3-NC
14	TBD	MON-B
8 15 7	Backward Alarm 4 is active Backward Alarm 4 is not active	BA-4-NO BA-4-COM BA-4-NC
12	Ground	GND

## 5.8 Unit Alarms (P5B)

Unit alarms are provided on a 15-pin male connector located on the rear panel of the modem. Refer to Table 5-8 for pin assignments.

**Table 5-8. Alarm Interface Connector Pin Assignments**

Pin #	Signal Function	Name
8 15 7	Rx Traffic (De-energized, Faulted) Rx Traffic (Energized, No Fault) RX Traffic	RX-NC RX-NO RX-COM
14 6 13	Tx Traffic (De-energized, Faulted) Tx Traffic (Energized, No Fault) Tx Traffic	TX-NC TX-NO TX-COM
5 12 4	Unit Fault (De-energized, Faulted) Unit Fault (Energized, No Fault) Unit Fault	UNIT-NC UNIT-NO UNIT-COM
11 3	RX I Channel (Constellation monitor) RX Q Channel (Constellation monitor)	RX-I RX-Q
10	No Connection	N/C
2	AGC Voltage (Rx signal level, 0 to 2.5 volts)	AGC
9	EXT Carrier OFF	EXT-OFF
1	Ground	GND

## 5.9 Auxiliary Serial Connector (P6)

Provides an RS-232 serial link between the modem and the CRS-150 1:1 Redundancy Switch.

**Table 5-9. Auxiliary Serial Connector (USB Type B Socket)**

Pin #	Description	Direction
1,4	Ground	
2	EIA-232 Transmit Data	Out
3	EIA-232 Receive Data	In



Although this port uses a USB connector, the signals are not USB compatible. Do NOT connect this port to the USB port of a PC, or other computing device.

## 5.10 Balanced G.703 Interface Connector (P7)

The Balanced G.703 connection is a 15-pin female connector located on the rear panel of the modem. Refer to Table 5-10 for pin assignments.

**Table 5-10. Balanced G.703 Interface Connector Pin Assignments**

Pin #	Signal Function	Name	Direction
1*	Drop Data Input ( - )	DDI-	In
9*	Drop Data Input ( + )	DDI+	In
2	Ground	GND	
10	Not Used		
3*	Insert Data Output ( - )	IDO-	Out
11*	Insert Data Output ( + )	IDO+	Out
4	Ground	GND	
12	Drop Data Output ( - )	DDO-	Out
5	Drop Data Output ( + )	DDO+	Out
13	Insert Data Input ( - )	IDI-	In
6	Insert Data Input ( + )	IDI+	In
14	Not Used		
7	Not Used		
15	Not Used		
8	Not Used		

\* Use for all non-Drop and Insert and T2/E2 balanced applications.



---

## 5.11 AC Power Connector

A standard, detachable, non-locking, 3-prong power cord (IEC plug) supplies the Alternating Current (AC) power to the modem. Note the following:

AC Power Specifications	
Input Power	40W maximum, 30W typical
Input Voltage	100 - 240 volts AC, +6%/-10% - autosensing (total absolute max. range is 90 - 254 volts AC)
Connector Type	IEC
Fuse Protection	1.25A Slow-blow (115 volt AC operation) 0.75A Slow-blow (230 volt AC operation) Line and neutral fusing 20 mm type fuses

---

## 5.12 Ground Connector

A #10-32 stud on the rear panel of the modem is used for connecting a common chassis ground among equipment.

**Note:** The AC power connector provides the safety ground.

This page is intentionally left blank.

# Chapter 6. FRONT PANEL OPERATION

## 6.1 Description

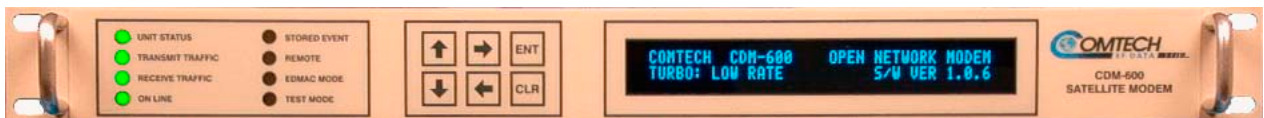

Figure 6-1. Front Panel View

The user can fully control and monitor the operation of the CDM-600 from the front panel, using the keypad and display. Nested menus are used, which display all available options, and prompt the user to carry out a required action.

The display has two lines each of 40 characters. On most menu screens, the user will observe a flashing solid block cursor, which blinks at a once-per-second rate. This indicates the currently selected item, digit, or field. Where this solid block cursor would obscure the item being edited (for example, a numeric field) the cursor will automatically change to an underline cursor.

If the user were to display the same screen for weeks at a time, the display could become 'burnt' with this image. To prevent this, the unit has a 'screen saver' feature that will activate after 1 hour. The top line of the display will show the Circuit ID (which can be entered by the user) and the bottom line will show the circuit Eb/No value (if the demod is locked) followed by 'Press any key....'. The message moves from right to left across the screen, then wraps around. Pressing any key will restore the previous screen.

The behavior of the front panel LEDs is described below in Table 6-1.

**Table 6-1. Front Panel LED Indicators**

LED	Color	Condition
Unit Status	Red	A Unit Fault exists (Example: PSU fault)
	Orange	No Unit Faults, but a Traffic Fault exists
	Green	No Unit Faults, or Traffic Faults
Transmit Traffic	Green	No Tx Traffic Faults
	Off	A Tx Traffic fault exists OR the Tx Carrier is in OFF state
Receive Traffic	Green	No Rx Traffic Faults (demod and Viterbi decoder are locked, everything is OK)
	Off	An Rx Traffic fault exists (the demod may still be OK)
On line	Green	The Unit is On Line, and carrying traffic
	Off	The Unit is Off Line (standby) - forced by externally connected 1:1 or 1:N redundancy system
Stored Event	Orange	There is a Stored Event in the log, which can be viewed from the front panel, or retrieved via the remote control interface
	Off	There are no Stored Events
Remote	Orange	The Unit is in Remote Mode - local monitoring is possible, but no local control
	Off	The Unit is in Local Mode - remote monitoring is possible, but no remote control
	Flashing	ODU control has been enabled, and there is a communications fault, or there is a ODU status fault
EDMAC Mode	Orange	Framing on, EDMAC on, and unit defined as Slave - local monitoring is possible, but no local control
	Off	Either no EDMAC, EDMAC Master, or Transparent mode is selected
Test Mode	Orange	A Test Mode is selected (Example: IF Loopback)
	Off	There is no Test Mode currently selected



***In general, the Alarm relay state will reflect the state of the Front Panel LEDs. For instance, if the Unit Status LED is red, the Unit Alarm relay will be active, etc. The one exception is the Transmit Traffic relay. This will only be activated if a Transmit Traffic Fault exists – it does not reflect the state of the TX carrier.***

The keypad is shown in Figure 6-2:

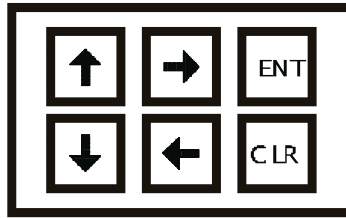

**Figure 6-2. Keypad**

The function of these keys is as follows:

<b>ENTER</b>	This key is used to select a displayed function or to execute a modem configuration change.
<b>CLEAR</b>	This key is used to back out of a selection or to cancel a configuration change which has not been executed using [ENTER]. Pressing [CLEAR] generally returns the display to the previous selection.
<b>Left, Right</b> [←], [→]	These arrows are used to move to the next selection or to move the cursor functions. At times, they may also be used to move from one section to another.
<b>Up, Down</b> [↑], [↓]	These arrows are used primarily to change configuration data (numbers). At times, they may also be used to move from one section to another.



***The keypad has an auto-repeat feature. If a key is held down for more than 1 second, the key action will repeat, automatically, at the rate of 15 keystrokes per second. This is particularly useful when editing numeric fields, with many digits, such as frequency or data rate.***

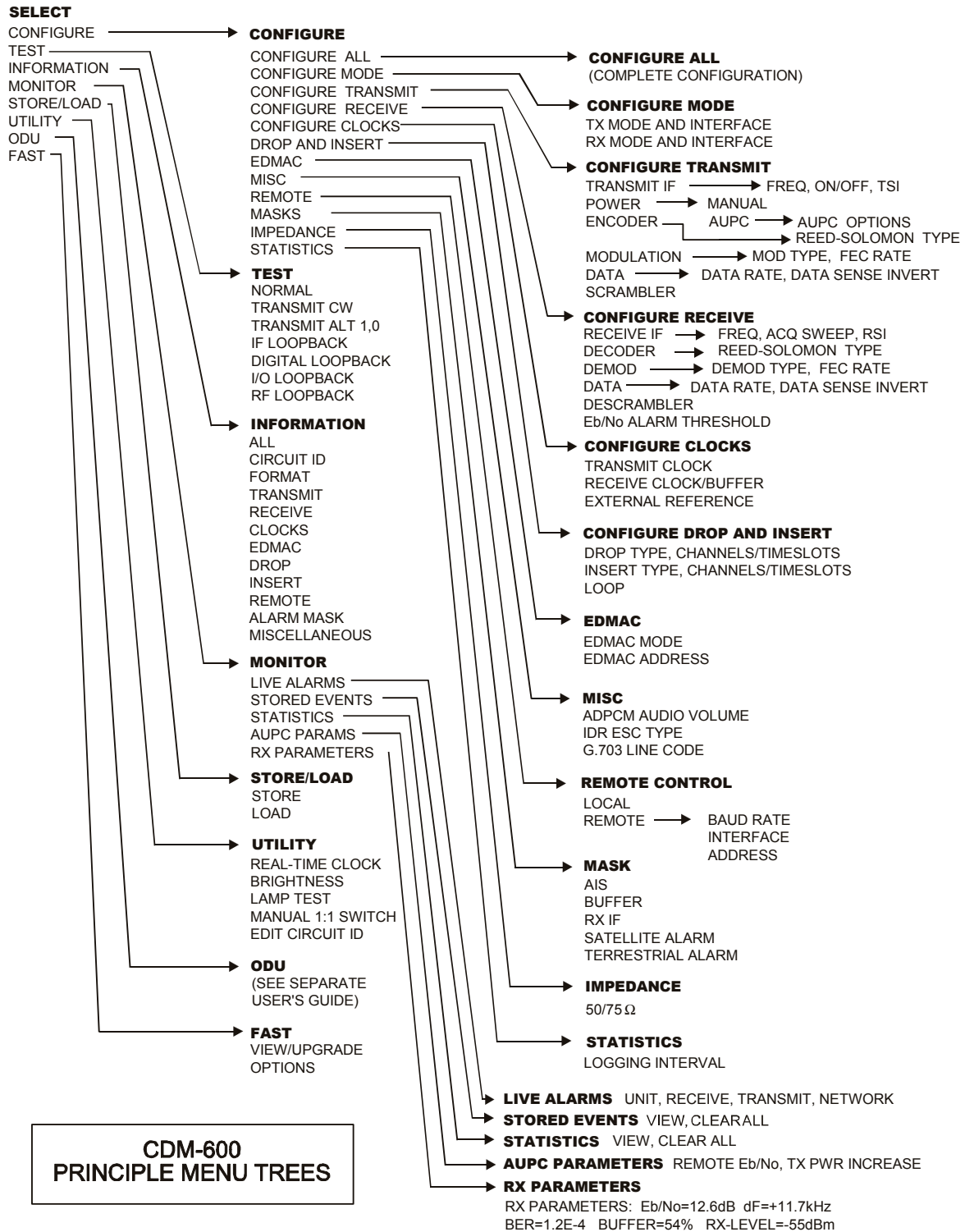

Figure 6-3. Menu Trees

## 6.2 Opening Screen

This screen is displayed whenever power is first applied to the unit:

```
COMTECH  CDM-600      OPEN NETWORK MODEM
TURBO:  TPC/LDPC      S/W VER 2.0.1
```

For units manufactured after February 2005 with the extended IF bandwidth feature:

```
COMTECH  CDM-600 (E)  OPEN NETWORK MODEM
TURBO:  TPC/LDPC      S/W VER 2.0.1
```

Press any key to go to the Main Menu screen. (Note: a **REF WARMING** message may be seen at this point - see Section 6.3.1.8.)

## 6.3 Main Menu

```
SELECT: CONFIGURATION  TEST  INFORMATION
MONITOR  STORE/LOAD  UTILITY  ODU  FAST
```

The following choices are presented:

<b>CONFIGURATION</b>	Permits the user to fully configure the modem.
<b>TEST</b>	Permits the user to configure the modem into one of several Test modes.
<b>INFORMATION</b>	Permits the user to view information on the modem, without having to go into the Configuration screens.
<b>MONITOR</b>	Permits the user to monitor the current status of the modem and view the log of stored events for the modem.
<b>STORE/LOAD</b>	Permits the user to store and retrieve up to 10 different modem configurations.
<b>UTILITY</b>	Permits the user to perform miscellaneous functions, such as setting the Real-Time Clock, adjusting the display brightness, etc.
<b>ODU (Outdoor Unit)</b>	Permits the user to monitor and control a Comtech EF Data RF Transceiver, if connected.
<b>FAST (Fully Accessible System Topology)</b>	Permits the user to configure different options, for extended data rates, interfaces, etc. Contact the factory for details.



*The actual choices displayed in the sub-menus may vary according to which FAST options have been enabled. Where a FAST option affects a menu, this is shown in the descriptive text.*

### 6.3.1 CONFIG

**CONFIG: ALL MODE TX RX CLOCKS D&I  
EDMAC MISC REMOTE MASK IMPED STATS**

The sub-branches available are:

<b>ALL</b>	Permits the user to completely configure the unit, being prompted, step by step, to make choices, or edit data. This is highly recommended for new users, as it will clearly lead the user through all the configuration parameters.
<b>MODE</b>	Permits the user to select Frame Type and Data Format for TX and RX.
<b>TX (Transmit)</b>	Permits the user to define, on a parameter-by-parameter basis, the TX configuration of the unit. These menu sub-branches would be used if the user wished to change, for example, just the TX Frequency.
<b>RX (Receive)</b>	Permits the user to define, on a parameter-by-parameter basis, the RX configuration of the unit. These menu sub-branches would be used if the user wished to change, for example, just the RX data rate.
<b>CLOCKS</b>	Permits the user to select TX-Clocking, RX-Buffer/Clock, or External Reference.
<b>D&amp;I</b>	Permits the user to select Drop or Insert options.
<b>EDMAC</b>	Permits the user to select EDMAC options.
<b>MISC</b>	Permits the user to select, view, or change various other parameters.
<b>REMOTE (Remote Control)</b>	Permits the user to define whether the unit is being controlled locally, or remotely, and to configure the Remote Control parameters: baud rate, I/O format, address.
<b>MASK</b>	Permits the user to activate or MASK an alarm condition.
<b>IMPED (Impedance)</b>	Permits the user to select the impedance at the IF connectors, either 50 or 75 $\Omega$ .
<b>STATS (Statistics)</b>	Permits the user to enable and configure the logging of various statistics, including Eb/No and AUPC parameters



***The modem may be monitored over the remote control bus at any time. When in Local mode, however, configuration parameters may only be changed through the front panel. Conversely, when in Remote mode, the unit may be monitored from the front panel, but configuration parameters may only be changed via the remote control bus.***



---

### 6.3.1.1 CONFIG: ALL

```
ALL = START
(STOP, START)
```

This menu permits the user to configure the unit, in a step-by-step process by viewing each menu in succession. Use the [←] [→] [↑] and [↓] arrow keys to select and edit the various parameters. Press ENTER to continue through all the configuration. Press CLEAR to discontinue.

---

### 6.3.1.2 CONFIG: MODE



*The **MODE** is a key parameter when configuring the modem. To simplify the menu choices, the user must first determine the **INTERFACE** and **FRAMING** type for both Transmit and Receive. Once these have been selected, the user is only presented with menu choices that are applicable to those particular modes.*

**Examples:**

- *If a G.703 interface is selected, the data rate menu will be restricted to only the appropriate G.703 rates.*
- *If an IDR framing mode is selected, the data rate choices will be limited to only those rates specified by IESS-308.*

```
MODE: TX=RS422:NONE RX=RS422:NONE
(NONE, IBS, IDR, INSERT, EDMAC, D&I++, ESC++)
```

Select **TX** and **RX** interface type and framing of the unit, using the [←] [→] [↑] [↓] arrow keys, then press ENTER.

The first parameter is the Interface type. The options are:

- RS422
- V.35
- RS232
- G703B (balanced)
- G703U (unbalanced)
- Audio (**FAST option**)
- LVDS

The **AUDIO** choice permits the user to carry 2 x 32 kbps ADPCM audio as the primary data. This mode forces IBS or EDMAC as the available framing types.

The second option is the Framing type.

The TX options are:

NONE  
IBS (FAST option)  
IDR (FAST option)  
DROP (FAST option)  
EDMAC  
D&I++ (FAST option) (Ver 1.5.0 or greater)  
ESC++ (Ver 2.0.1 or greater)

The RX options are:

NONE  
IBS (FAST option)  
IDR (FAST option)  
INSERT (FAST option)  
EDMAC  
D&I++ (FAST option) (Ver 1.5.0 or greater)  
ESC++ (Ver 2.0.1 or greater)

---

### 6.3.1.3 CONFIG: TX

```
TX-IF: POWER ENCODER MOD DATA SCRAMBLER  
DATA=20000.000kbps SYMBOL=10000.000ksym
```

Select the parameters on the top line to be edited using the [←] [→] arrow keys. Observe the Data/Symbol rates on the bottom line. Press ENTER

### CONFIG: TX: TX-IF

```
TX-IF: CARRIER = ON (ON, OFF, RTI)  
TX FREQ=176.0000MHZ SPECTRUM
```

Three TX settings can be set from this menu. Select the parameter to edit using the [←] [→] arrow keys. The options for the TX carrier are shown in parentheses. To change the settings use the [↑] [↓] arrow keys. Select either ON, OFF, or RTI, then press ENTER.



***RTI means RECEIVE/TRANSMIT INHIBIT. When selected, it will prevent the TX carrier from being transmitted, until the demodulator is locked. To avoid the Tx Carrier from being turned off when the demodulator loses lock for a very short period of time, the demodulator must be unlocked continuously for a period of 10 seconds before the transmit carrier is inhibited. This time interval is fixed and the user cannot change it. Having this feature enabled does not affect the internal IF loopback feature. But, be aware that if an external IF loopback is attempted (connecting an external cable from the Tx IF output to the Rx IF input), then this will not work! (The Tx carrier cannot turn on until the demod is locked, and the demod cannot lock, because the TX output is off. The net result is that the demod will not lock, and the Tx carrier will not turn on. USE THE RTI FEATURE WITH EXTREME CARE!***

Select each digit of the TX frequency to be edited using the [←] [→] arrow keys. Edit the value of the digit using the [↑] [↓] arrow keys. When editing is complete, press ENTER. Note that the range is from 52 to 88 MHz, and 104 to 176 MHz. The resolution is 100Hz.

For units manufactured after February 2005, and which display **CDM-600 (E)** on the opening menu, the range of IF frequencies has been extended to 50 - 90 MHz, and 100 - 180 MHz.



***SPECTRUM INVERT should normally be in the OFF position. When in the ON position, for all FEC types, except BPSK, the transmit spectrum is inverted (which is the same as reversing the direction of phase rotation in the modulator). In BPSK, the time-order of bits out of the FEC encoder is reversed, to make the modem compatible with certain other manufacturer's modems.***

## CONFIG: TX: POWER

```
OUTPUT POWER: MODE = MANUAL (MANUAL, AUPC)
OUTPUT POWER LEVEL = -20.0 dBm
```

Select the parameter to edit using the [←] [→] arrow keys. Edit the output level mode, either **MANUAL** or **AUPC**, using the [↑] [↓] arrow keys. Select each digit of the TX Power Level using the [←] [→] arrow keys. Edit the value of the digit using the [↑] [↓] arrow keys. When editing is complete, press ENTER.

If **AUPC** mode is selected, the lower line changes:

(Note that **EDMAC**, or **D&I++**, or **ESC++** framing must be enabled for AUPC to function.)

```
OUTPUT POWER: MODE = AUPC (MANUAL, AUPC)
TARGET-EbNo/RANGE      ALARM/ACTION
```

Use the [←] [→] arrow keys to select either **TARGET-EbNo/RANGE** or **ALARM ACTION**, then press ENTER

If **TARGET-EbNo/RANGE** is selected, the following menu will be displayed:

```
MINIMUM EbNo OF REMOTE MODEM = 5.0dB
MAXIMUM PERMITTED POWER INCREASE = 9dB
```

Edit the target Eb/No of the remote modem. The default value is 3.0 dB, and upper limit is 9.9 dB. Edit the maximum permitted increase in power level when in AUPC mode. The default value is 1dB, and upper limit is 9 dB. The user should then press ENTER.

If **ALARM ACTION** is selected, the following menu will be displayed:

```
MAX TX PWR ACTION = NONE (NONE, TX-ALM)
REM DEMOD UNLOCK ACT = NOM-PWR (NOM, MAX)
```

Select the action that will occur if the **AUPC** causes the maximum output power level to be reached, either **NONE** or **TX ALARM**.

Select the action that will occur if the remote demod is unlocked. The choices are: **NOM-PWR** (Nominal Power), where the output level will revert to the nominal power level set under **MANUAL** or **MAX-PWR**, (Maximum Power), where the output level will change to the maximum permitted. The user should then press **ENTER**.

## CONFIG: TX: ENCODER

```
ENCODER = TPC (NONE, VIT, SEQ, TCM, TPC, LDPC)
REED-SOLOMON= OFF (ON, OFF)
```

Select the parameter to edit using the [←] [→] arrow keys.

The Encoder options are shown in the parentheses. Select using the [↑] [↓] arrow keys, then press **ENTER**. The choices are:

- Viterbi
- Sequential
- Trellis Coded Modulation - 8-PSK Rate 2/3 only (**FAST option**)
- TPC (Turbo) (**Hardware option**)
- None (uncoded)
- LDPC (**Hardware option**) **Note:** This option of encoding is only displayed if the TPC/LDPC Codec is installed.

Select **ON** or **OFF** for Reed-Solomon using the [↑] [↓] arrow keys, then press **ENTER**. If Reed-Solomon is **ON**, proceed to the next menu.

If **None** is selected, the bottom line of the display will change from the R-S selection to the Differential Encoding selection, as shown below:

```
ENCODER = NONE (NONE, VIT, SEQ, TCM, TPC, LDPC)
DIFF-ENCODER= OFF (ON, OFF)
```



*If the user selects Differential Encoding=OFF, there is no way for the modem to resolve the phase ambiguities associated with PSK modulations. For BPSK there is a 1 in 2 chance that the polarity of the data will be correct. IN QPSK there is a 1 in 4 chance the data will be correct.*

## CONFIG: TX: ENCODER: REED-SOLOMON ON

```
REED-SOLOMON ENCODING = ON(200/180)
```

Use the [↑] [↓] arrow keys to select one of the listed parameters, and press ENTER. Selections depend on the Framing mode. Possible selections include:

- IESS-310 (219/201), open or closed network
- IBS (126/112), open or closed network
- EDMAC (200/180), closed network
- IDR (225/205), open network
- IDR (194/178), open network
- UNFRAMED (220/200), closed network
- LEGACY EF DATA (225, 205 with V.356 scrambling), closed network

## CONFIG: TX: MODULATION

```
MODULATION= QPSK (B,Q,OQ-PSK)
FEC RATE = 1/2 (1/2,3/4,7/8)
```

Select one of the parameters using the [←] [→] arrow keys, and then edit using the [↑] [↓] arrow keys. Edit the Modulation type and the FEC rate.

The Encoder type dictates the Modulation Type and FEC rate choices:

<b>No Encoder:</b>	BPSK	Fixed at 1/1
	QPSK, OQPSK	Fixed at 1/1
<b>Non-Turbo Encoder:</b>	BPSK	fixed at Rate 1/2
	TCM 8-PSK	fixed at Rate 2/3 (FAST option)
	QPSK, OQPSK	1/2, 3/4 or 7/8
	16-QAM	3/4 or 7/8 (Viterbi + Reed-Solomon only)
<b>Turbo (with the 5 Mbps Codec Installed):</b>	BPSK	5/16 or 21/44
	QPSK, OQPSK,	fixed at 3/4
	8-PSK, 16-QAM	fixed at 3/4 (FAST option)
<b>Turbo (with the 20 Mbps Codec Installed, or the TPC/LDPC Codec installed):</b>	BPSK	5/16 or 21/44
	QPSK, OQPSK,	1/2, 3/4, 7/8 or 0.95
	8-PSK	3/4, 7/8, and 0.95 (FAST option)
	16-QAM	3/4 and 7/8 (FAST option)
<b>LDPC (with TPC/LDPC Codec installed):</b>	BPSK	1/2
	QPSK, OQPSK,	1/2, 2/3, 3/4
	8-PSK, 8-QAM	2/3, 3/4 (FAST Option)
	16-QAM	3/4 (FAST option)

The following window will appear if the TPC/LDPC Codec is installed:

```
MODULATION= QPSK (B,Q OQ,8PSK,16Q,8QAM)
FEC RATE = 1/2 (1/2,3/4,7/8)
```

## CONFIG: TX: DATA

```
TX DATA RATE = 01544.000 kbps  
DATA INVERT = OFF (ON,OFF)
```

The top line permits the data rate to be edited. Select the digit of Transmit Data Rate to be edited using the [←] [→] arrow keys. The value of the digit is changed using the [↑] [↓] arrow keys. Press ENTER.

**NOTE:** The minimum and maximum data rates are dependent on Modulation type and FEC encoder Rate. If the user changes the Modulation or FEC, and the data rate becomes invalid, the **Data Rate** will be adjusted automatically. The upper range of data rate will be dictated by the **FAST option** installed.

When Drop Framing or the G.703 interface type is used the [↑] [↓] arrow keys will scroll through the available data rates. If in Drop Mode and the data rate is edited to 1920 kbps, a comment is shown to indicate that E1 fixed channel mode will be implemented.

When G.703 is used and the Modem is Hardware Revision 2.0 or higher, three auxiliary rates will also be available (512, 1024 and 2048 kbps) indicated by the word AUX appearing to the right of the decimal place. (For example, 00512.AUX kbps). Refer to Section 4.3 IDI/DDO connectors for information on how to connect the cables for the AUX data rates.

The bottom line permits the user to select the data inversion feature (added for compatibility with certain older equipment). Select either ON or OFF, using the [↑] [↓] arrow keys, then press ENTER.

## CONFIG: TX: SCRAMBLER

```
TX SCRAMBLER = ON (ON,OFF)  
FRAME SCRAMBLER
```

Select either **ON** or **OFF**, using the [↑] [↓] arrow keys, then press ENTER.

The choice of scrambler is selected automatically, and will be depend on the exact operating mode. For example, if no framing is being used, the ITU V.35 scrambler (Intelsat variant) will be used. If IBS framing is selected, the IESS-309 scrambler will be used, etc. If Turbo encoding is used a second scrambler selection is available: IESS-315 V.35 instead of the TPC scrambler.

```
TX SCRAMBLER = IESS (NORMAL,IESS,OFF)  
IESS-315 V.35 SCRAMBLER
```

If LDPC encoding is selected the standard ITU V.35 scrambler will be used.

---

### 6.3.1.4 CONFIG: RX

```
RX-IF DECODER DEMOD DATA DESCRAM EbNo  
DATA=00064.000kbps SYMBOL=00037.333ksym
```

The sub-branches available are:

#### CONFIG: RX: RX-IF

```
ACQUISITION SWEEP RANGE = +/- 32 kHz  
RX FREQ=070.0000 MHz SPECTRUM INVERT=OFF
```

Edit the Acquisition Sweep Range of the demodulator. The value of the digit is changed using the [↑] [↓] arrow keys. Press ENTER.

The value entered determines the amount of frequency uncertainty the demodulator will sweep over in order to find and lock to an incoming carrier. When operating at low bit rates, large values of sweep range (compared to the data rate) will cause excessively long acquisition times. For example: selecting  $\pm 32$  kHz with a data rate of 2.4 kbps, BPSK, will result in an average acquisition time of around 3 minutes.

Edit the Receive Frequency (RX FREQ) of the demodulator. Select the digit to be edited using the [←] [→] arrow keys. The value of the digit is changed using the [↑] [↓] arrow keys. Press ENTER. Note that the range is from 52 to 88 MHz, and 104 to 176 MHz. The resolution is 100Hz.

For units manufactured after February 2005, and which display **CDM-600 (E)** on the opening menu, the range of IF frequencies has been extended to 50 - 90 MHz, and 100 - 180 MHz.



***SPECTRUM INVERT should normally be in the OFF position. When in the ON position, the receive spectrum is inverted (which is the same as reversing the direction of phase rotation in the demodulator). Note that in BPSK mode, the demodulator will automatically synchronize to either the normal time-ordering of bits FEC codeword pairs, or the inverted ordering used by certain other manufacturers.***



## CONFIG: RX: DECODER

```
DECODER = VIT NONE, VIT, SEQ, TCM, TPC, LDPC)
REED-SOLOMON = OFF (ON, OFF)
```

Select the parameter to edit using the [←] [→] arrow keys.

The Decoder options are shown in the parentheses. Select using the [↑] [↓] arrow keys, then press ENTER. The choices are:

- Viterbi
- Sequential
- Trellis Coded Modulation - 8-PSK Rate 2/3 only (**FAST option**)
- TPC (Turbo) (**Hardware option**)
- None (uncoded)
- LDPC (**Hardware option**)      **Note:** This option of decoding is only displayed if the TPC/LDPC Codec is installed.

Select ON or OFF for Reed-Solomon using the [↑] [↓] arrow keys, then press ENTER. If Reed-Solomon is ON, proceed to the next menu.

If NONE is selected, the bottom line of the display will change from the RS selection to the Differential Encoding selection, as shown below:

```
DECODER = NONE (NONE, VIT, SEQ, TCM, TPC, LDPC)
DIFF-DECODER= OFF (ON, OFF)
```



*If the user selects Differential Decoding = OFF, there is no way for the modem to resolve the phase ambiguities associated with PSK modulations. For BPSK there is a 1 in 2 chance that the polarity of the data will be correct. In QPSK there is a 1 in 4 chance that the data will be correct.*

## CONFIG: RX: DECODER: REED-SOLOMON ON

```
REED-SOLOMON DECODING = ON(200/180)
```

Use the [↑] [↓] arrow keys to select one of the listed parameters, and press ENTER. Selections depend on the Framing mode. Possible selections include:

- IESS-310 (219/201), open or closed network
- IBS (126/112), open or closed network
- EDMAC (200/180), closed network
- IDR (225/205), open network
- IDR (194/178), open network
- UNFRAMED (220/200), closed network
- LEGACY EF DATA (225,205, with V.35 scrambling), closed network

## CONFIG: RX: DEMODULATION

```
DEMODULATION = QPSK (B, Q, OQ, 8PSK, 16QAM)
FEC RATE = 1/2 (1/2, 3/4, 7/8)
```

Select one of the parameters using the [←] [→] arrow keys, and then edit using the [↑] [↓] arrow keys. Edit the Demodulation type and the FEC rate.

The Decoder type dictates the FEC Rate choices:

<b>No Encoder:</b>	BPSK	Fixed at 1/1
	QPSK, OQPSK	Fixed at 1/1
<b>Non-Turbo Encoder:</b>	BPSK	fixed at Rate 1/2
	TCM 8-PSK	fixed at Rate 2/3 (FAST option)
	QPSK, OQPSK	1/2, 3/4 or 7/8
	16-QAM	3/4 or 7/8
<b>Turbo (with the 5 Mbps Codec Installed):</b>	BPSK	5/16 or 21/44
	QPSK, OQPSK,	fixed at 3/4
	8-PSK, 16-QAM	fixed at 3/4 (FAST option)
<b>Turbo (with the 20 Mbps Codec Installed, or the TPC/LDPC Codec installed):</b>	BPSK	5/16 or 21/44
	QPSK, OQPSK,	1/2, 3/4, 7/8 or 0.95
	8-PSK	3/4, 7/8, and 0.95 (FAST option)
	16-QAM	3/4 and 7/8 (FAST option)
<b>LDPC (with TPC/LDPC Codec installed):</b>	BPSK	1/2
	QPSK, OQPSK,	1/2, 2/3, 3/4
	8-PSK, 8-QAM	2/3, 3/4 (FAST Option)
	16-QAM	3/4 (FAST option)

The following window will appear if the TPC/LDPC Codec is installed:

```
DEMODULATION= QPSK (B, Q OQ, 8PSK, 16Q, 8QAM)
FEC RATE = 1/2 (1/2, 3/4, 7/8)
```

## CONFIG: RX: DATA

```
RECEIVE DATA RATE = 00064.000 kbps
DATA INVERT = OFF (ON, OFF)
```

The top line permits the data rate to be edited. Select the digit of the Receive Data Rate using the [←] [→] arrow keys. Edit the value of the digit using the [↑] [↓] arrow keys. Press ENTER.

**NOTE:** The minimum and maximum data rates are dependent on Demodulation type and FEC decoder Rate. If the user changes the Modulation or FEC, and the data rate becomes invalid, the **Data Rate** will be adjusted automatically. The upper range of data rate will be dictated by the **FAST option** installed.

When Insert Framing or the G.703 interface type is used the [↑] [↓] arrow keys will scroll through the available data rates. If in Drop Mode and the data rate is edited to 1920 kbps, a comment is shown to indicate that E1 fixed channel mode will be implemented. The bottom line permits the user to select the data inversion feature (added for compatibility with certain older equipment). Select either ON or OFF, using the [↑] [↓] arrow keys, then press ENTER.

When G.703 is used and the Modem is Hardware Revision 2.0 or higher, three auxiliary rates will also be available (512, 1024, and 2048 kbps) indicated by the word AUX appearing to the right of the decimal place. (For example, 00512.AUX kbps).

Refer to Section 4.3 IDI/DDO connectors for additional information about how to connect the cables for the new AUX data rates.

The bottom line permits the user to select the data inversion feature (added for compatibility with certain older equipment). Select either ON or OFF, using the [↑] [↓] arrow keys, then press ENTER.

## CONFIG: RX: DESCRAMBLER

```
RX DESCRAMBLER = ON (ON,OFF)
FRAME DESCRAMBLER
```

Select either ON or OFF, using the [↑] [↓] arrow keys, then press ENTER.

The choice of descrambler is selected automatically, and will be depend on the exact operating mode. For example, if no framing is being used, the ITU V.35 descrambler (Intelsat variant) will be used. If IBS framing is selected, the IESS-309 descrambler will be used.

If Turbo decoding is used a second scrambler selection is available: IESS-315 V.35 instead of the TPC scrambler.

```
RX DESCRAMBLER = IESS (NORMAL,IESS,OFF)
IESS-315 V.35 DESCRAMBLER
```

If LDPC decoding is selected the standard ITU V.35 descrambler will be used.

## CONFIG: RX: EbNo

RECEIVE EbNo ALARM POINT = 02.0 dB

Select the digit of the Alarm point to be edited using the [←] [→] arrow keys. Edit the value of the digit using the [↑] [↓] arrow keys. Press ENTER.

The range of values is from 00.1 to 16.0 dB. The user may select a value here, and if the Eb/No falls below this value, a receive traffic fault will be generated.

---

### 6.3.1.5 CONFIG: CLOCKS

CLOCKING: TX-CLOCK RX-BUFFER/CLOCK  
EXT-BASEBAND-CLK EXT-FREQ-REF INT-REF

The sub-branches available are:

#### CONFIG: CLOCKS: TX CLOCK

TRANSMIT CLOCK = INTERNAL (SCT)  
(INT (SCT) , TX-TERR (TT) , RX-LOOP , EXT-CLK)

Use the [↑] [↓] arrow keys to select from the choices shown in parentheses, then press ENTER.

<b>INTERNAL (SCT)</b>	Indicates that the unit will supply a clock to the DTE, which is derived from its internal high-stability source. This is the required setting when the TX interface type is Audio.
<b>TX-TERRESTRIAL (TT)</b>	Indicates that the unit expects to receive a clock from the DTE, to which the unit can phase-lock its internal circuits. If no clock is detected the modem will substitute its internal clock and generate an alarm. This is the required setting when the modem's interface type is G.703.
<b>RX-LOOP</b>	Will allow the modem's internal clock to be phase locked to the RX buffer clock source. This output clock is Send Timing. Choosing RX-LOOP will not automatically select RX-SAT as the buffer clock source. This allows for increased flexibility for modem clock selection. Normally the user will select RX-SAT but the other choices also are available.  Example: The user has an available high stability 10 MHz clock source but the end equipment will only accept a clock at the information data rate. Selecting TX Clock = RX-LOOP and RX buffer clock as EXT-REF will provide receive timing and send timing to the end equipment that is sourced from the 10 MHz reference.
<b>EXTERNAL CLOCK</b>	Indicates that an unbalanced high-stability source is expected at the J9 BNC connector, or a balanced version at the P3A connector. The frequency must match that programmed in the CONFIG: CLOCKS, EXTERNAL-BASEBAND-CLOCK menu, and must be equal to the TX data rate.

## CONFIG:CLOCKS: RX BUFFER/CLOCK

```
CLK= RX-SAT (RX-SAT, TX-TERR, EXT-CLK, INS)
BUFFER-SIZE = 00016bytes(00002ms) CENTER
```

Use the [←] [→] arrow keys to select one of the three parameters on the screen to edit. Edit the RX clock options using the [↑] [↓] arrow keys, then press ENTER

<b>RX-SAT</b>	Sets the Receive buffer clock source to the satellite clock (The receive buffer will be bypassed.) Note: This will fix the buffer size to minimum.
<b>TX-TERR</b>	In this timing mode, data is clocked out of the receive buffer using the external transmit clock.
<b>EXT-CLK</b>	In this timing mode, data is clocked out of the receive buffer using an External clock.
<b>INS</b>	Sets the buffer clock to the Insert stream (INSERT mode only).

Buffer-Size indicates the size, in bytes, of the Plesiochronous/Doppler Buffer. In parentheses after this, the size in milliseconds is shown. Edit each digit of the buffer size using the [↑] [↓] arrow keys. Press ENTER.

**Note:** When the RX data rate is set to one of the four G.703 rates, the minimum buffer size and step size are limited to the value shown in the table below. In addition, Insert Framing follows the same rule, regardless of n x 64 data rate, depending upon whether the Insert Type is T1 or E1. If none of these cases is true, the minimum buffer size is 16 bytes with a step size of 2 bytes.

RX Data Rate	Buffer Step Size
1544 kbps (T1) or open network D&I at T1	1158 bytes or 3 milliseconds for D4 (6 milliseconds for ESF)
2048 kbps (E1) or open network D&I at E1	1024 bytes or 4 milliseconds
D&I++ at n = 1, 3 or 5	720 bytes
D&I++ at n = 2, 6 10 or 15	1440 bytes
D&I++ at n = 9	2160 bytes
D&I++ at n = 4, 12 or 20	2880 bytes
D&I++ at n = 18	4320 bytes
D&I++ at n = 7 or 21	5040 bytes
D&I++ at n = 8 or 24	5760 bytes
D&I++ at n = 11	7920 bytes
D&I++ at n = 13	9360 bytes
D&I++ at n = 14	10080 bytes
D&I++ at n = 16	11520 bytes
D&I++ at n = 17	12240 bytes
D&I++ at n = 19	13680 bytes
D&I++ at n = 22	15840 bytes
D&I++ at n = 23	16560 bytes
6312 kbps (T2)	1578 bytes or 2 milliseconds
8448 kbps (E2)	528 bytes or 0.5 milliseconds

If CENTER is selected, the following sub-menu is displayed:

### **CONFIG: CLOCKS: RX BUFFER/CLOCK: CENTER**

```
PRESS ENTER TO CENTER THE BUFFER  
OTHERWISE, PRESS CLEAR
```

Follow the instructions on the screen.

### **CONFIG: CLOCKS: EXT-BASEBAND-CLOCK**

```
EXTERNAL BASEBAND CLOCK = 02048.000 kHz  
TYPE = UNBAL (UNBAL,BAL)
```

To edit the **EXTERNAL BASEBAND CLOCK**, select the digit to be edited using the [←] [→] arrow keys. Edit the value of the digit using the [↑] [↓] arrow keys. Press ENTER.

### **CONFIG: CLOCKS: EXT-FREQ-REF**

```
EXTERNAL FREQUENCY REFERENCE: INTERNAL  
(HIGH-STABILITY INTERNAL, 1, 2, 5, 10, 20MHZ)
```

For units with Firmware Version: 1.4.0 or greater, and with a High-Stability module installed:

Edit the selection using the [↑] [↓] arrow keys. Press ENTER.

### **CONFIG: CLOCKS: INTERNAL REFERENCE**

```
INTERNAL HI-STABILITY 10 MHz REFERENCE  
FINE ADJUST: +048 (+/-999)
```

For units with Firmware Version: 1.4.0 or greater, with a High-Stability module installed, and with the Hi-Stability Internal 10 MHz Reference selected:

Very fine adjustment of the Internal 10MHz Reference may be made. The adjustment value is retained in EEPROM memory, and hence is not lost when the Nvram memory is cleared (which happens on uploading new firmware). Note: changes made to the adjust value are implemented immediately, not after the ENTER key is pressed.

Select the digit to be edited using the [←] [→] arrow keys. Edit the value of the digit using the [↑] [↓] arrow keys. Press ENTER.

### 6.3.1.6 CONFIG: DROP & INSERT



*Drop and Insert is discussed in the Chapter “Clock modes and Drop and Insert (D&I)” later in this manual.*

```
DRP-TYPE= T1-D4  CHAN/TS  LOOP=Y (Y/N)
INS-TYPE= T1-D4  CHAN/TS
```

Using the [←] [→] arrow keys, select one of the five parameters on the screen. Note that Drop and Insert operation is a **FAST** option. Selecting **LOOP** will tie **Drop Data Out (DDO)** to **Insert Data Input (IDI)** without the user having to externally connect cables to these ports.

The Drop-Type and Insert-Type and Loop (Y/N) are edited on this screen using the [↑] [↓] arrow keys. The Drop & Insert-Types are:

- T1 – D4
- T1 – ESF
- E1 – CCS
- E1 – CAS

To edit the Channel Timeslots (CHAN/TS) for either Drop or Insert, press ENTER and another screen will be shown:

#### CONFIG: DROP & INSERT: DROP CHANNEL TIMESLOTS

```
DRP-CH:  1    2    3    4
         TS: 01  02  03  04
```

Select the Time-slot to edit using the [←] [→] arrow keys and edit the value using the [↓] [↑] arrow keys, then press ENTER.

The number of Channels and Time-slots shown depends on the data rate.

If the data rate is 1920 kbps, then only the E1 formats are available, and the **CHAN/TS** menus are disabled. This is the ‘fixed channel’ mode where all timeslots are allocated in order.



## CONFIG: DROP & INSERT: INSERT CHANNEL TIMESLOTS

```
INS-CH: 1   2   3   4
        TS: 01 02 03 04
```

Select the Time-slot to edit using the [←] [→] arrow keys and edit the value using the [↑] [↓] arrow keys, then press ENTER.

The number of Channels and Time-slots shown depends on the data rate.

If the data rate is 1920 kbps, then only the E1 formats are available, and the **CHAN/TS** menus are disabled. This is the 'fixed channel' mode where all timeslots are allocated in order.

---

### 6.3.1.7 CONFIG: EDMAC

```
EDMAC MODE = MASTER (IDLE/MASTER/SLAVE)
EDMAC ADDRESS = XXXX
```

Select either **IDLE**, **MASTER**, or **SLAVE**, using the [↑] [↓] arrow keys, then press ENTER.

- An **EDMAC MASTER** is a unit which is local to the M&C computer, and which passes messages, via the overhead, to a distant-end modem. The **MASTER** address will always end in 0.
- An **EDMAC SLAVE** is a unit, which is not local to the M&C computer, which is at the distant-end of a satellite link. The **SLAVE EDMAC** address will always end in 1.

See Chapter 11 EDMAC for more information.

---

### 6.3.1.8 CONFIG: MISC

```
MISC: G.703-LINE-CODE IDR-ESC-TYPE
ADPCM-AUDIO-VOL HI-RATE-ESC WARM-UP
```

Select the parameter to edit using the [←] [→] arrow keys, then press ENTER.

## CONFIG: MISC: G.703 CODE

```
Tx G703/DDO CODE = AMI (AMI, B8ZS)
Rx G703/IDI CODE = AMI (AMI, B8ZS)
```

Parameters may only be edited if the Interface Type is G.703.

Use the [←] [→] arrow keys to select the parameter to edit. Select either appropriate G.703 code using the [↑] [↓] arrow keys, then press ENTER.

Note that the choices displayed here will depend on the G.703 interface type, which has been selected. The choices are:

- HDB3 (for E1, E2 or sub-rate operation)
- B8ZS ( for T1 and unbalanced T2 operation)
- B6ZS (for balanced T2 operation)

## CONFIG: MISC: IDR-ESC-TYPE

```
TX-IDR-TYPE: 64k DATA (64k DATA, AUDIO)
RX-IDR-TYPE: 64k DATA (64k DATA, AUDIO)
```

Parameters may only be edited if the Framing Mode is IDR.

This menu permits a user to decide if the 64 kbps channel in the IDR overhead (normally reserved for the two 32 kbps ADPCM audio channels) should carry user data instead. The rear panel Overhead connector provides the appropriate EIA-422 interface for this option.

Use the [←] [→] arrow keys to select the parameter to edit. Select the appropriate IDR-ESC Type, using the [↑] [↓] arrow keys, then press ENTER.

## CONFIG: MISC: ADPCM AUDIO VOLUME

```
TX-1 VOLUME= +0 dB    TX-2 VOLUME= -2 dB
RX-1 VOLUME= +2 dB    RX-2 VOLUME= -4 dB
```

This menu permits the gain (or volume) of the audio ESC circuits, for both Receive and Transmit, to be varied. Note that the step size is 2dB.

Select the appropriate volume, using the [←] [→] arrow keys, and edit the volume using the [↑] [↓] arrow keys, and press ENTER.

## CONFIG: MISC: HIGH-RATE-ESC

```
HIGH-RATE-ESC = OFF (ON,OFF)
BAUDRATE = 9600 PARITY:DATA:STOP = N81
```

The ESC type defined here depends on the framing type selected under **CONFIG, MODE**. The two options are either **High-Rate IBS ESC**, or **ESC++**

For units with Firmware Version: 1.3.1 or greater: The High Rate IBS (Engineering Service Channel) is available as a FAST option in conjunction with IBS framing. If enabled, the lower of the TX or RX primary data rate, according to the table below, limits the maximum baud rate. Both TX and RX framing must be IBS to enable this feature.

<u>Data rate</u>	<u>Max ESC baud rate</u>
64 kbps	2400
> 127.999 kbps	4800
> 255.999 kbps	9600
> 383.999 kbps	14400
> 511.999 kbps	19200
> 767.999 kbps	28800
> 1023.999 kbps	38400

For units with Firmware Version: 2.0.1 or greater: ESC++ is available as standard. If enabled, the lower of the TX or RX primary data rate, according to the table below, limits the maximum baud rate. Both TX and RX framing must be set to ESC++. See Chapter 13 for more details on the framing used.

<u>Data rate</u>	<u>Max ESC++ baud rate</u>
>= 64 kbps	4800
>= 128 kbps	9600
>= 192 kbps	14400
>= 256 kbps	19200
>= 384 kbps	28800
>= 512 kbps	38400

## CONFIG: MISC: WARM-UP

```
HIGH-STAB REFERENCE POWER-UP WARM-UP :
NO DELAY (INSTANT-ON) (INSTANT-ON, DELAY)
```

For units with Firmware Version: 1.4.0 or greater, and with a High-Stability module installed: The High-Stability Reference Module contains an oven for the crystal. It can take a little time for the oven & crystal to come up to temperature. During this time, the frequency accuracy is not guaranteed. This menu allows the user to select a warm-up delay, which will be implemented on power-up. The delay is calculated by the modem, based on temperature and the amount of time the unit was turned off.

If the Warm-up Delay is enabled, when the modem is powered up, a Warm-Up Delay Countdown will be activated, during which the TX is suppressed. The Countdown of the remaining Warm-up Delay is displayed on the front panel, for example:

```
COMTECH CDM-600      OPEN NETWORK MODEM  
HIGH-STABILITY REF WARMING UP: 045 SEC
```

If necessary, this Warm-up period can be by-passed by pressing the CLEAR key.

---

### 6.3.1.9 CONFIG: REMOTE CONTROL

```
REMOTE CONTROL = LOCAL (LOCAL,REMOTE)
```

Select **LOCAL** or **REMOTE** using the [↑] [↓] arrow keys, then press ENTER.

If **LOCAL** is selected, the **REMOTE CONTROL** is disabled. Remote monitoring is still possible.

If **REMOTE** is selected, then the following sub-menus will be displayed.

#### ONFIG: REMOTE CONTROL: INTERFACE

```
INTERFACE= RS-485-4W (232,485-2,485-4)  
ADDRESS= 0001      BAUDRATE= 9600
```

Use the [←] [→] arrow keys to select the parameter to edit: **Interface**, **Address** or **Baudrate**.

Edit the Interface type, Baudrate and each digit of the Address using the [↑] [↓] arrow keys.

- For EIA-485, the permitted address range is 1 to 9999.
- Address 0 is reserved for universal addressing.
- For EIA-232, the Address is fixed at 0000.

## CONFIG: REMOTE CONTROL: CHAR FORMAT

```
PARITY:DATA-BITS:STOP-BITS = N81  
                          (N81,E72,O72)
```

Edit the I/O character format using the [↑] [↓] arrow keys. The options are:

N81	No parity	8 Data bits	1 Stop bit
E72	Even parity	7 Data bits	2 Stop bits
O72	Odd parity	7 Data bits	2 Stop bits

---

### 6.3.1.10 CONFIG: MASK

These sub-menus permit the user to selectively mask, or make active, various alarms and traffic conditions that are monitored in the unit.

```
CONFIGURE ALARM MASK:  AIS  BUFFER  
                      RXIF  SAT-ALM  TERR-ALM
```

Use the [←] [→] arrow keys to select the parameter to edit, then press ENTER. One of the following sub-menus will be displayed:

#### CONFIG: MASK: AIS

```
AIS:  TX-TERR-AIS= MASKED  (ACTIVE,MASK)  
      RX-SAT-AIS = ACTIVE  (ACTIVE,MASK)
```

Use the [←] [→] arrow keys to select the parameter to edit: Select either **ACTIVE** or **MASKED**, using the [↑] [↓] arrow keys, then press ENTER.

- If TX-TERR-AIS is set to **ACTIVE**, a fault will be generated whenever the modulator senses that the ‘all ones’ condition is present in the terrestrial data.
- If RX-SAT-AIS is set to **ACTIVE**, a fault will be generated whenever the demodulator senses that the ‘all ones’ condition is present in the receive data.
- If an alarm is **MASKED**, no alarm will be generated.

## CONFIG: MASK: BUFFER SLIP

```
BUFFER SLIP= ACTIVE (ACTIVE, MASK)
```

Select either **ACTIVE** or **MASKED**, using the [↑] [↓] arrow keys, then press ENTER.

- If the user selects **ACTIVE**, then a Buffer Slip fault will be generated whenever the receive circuitry senses that the buffer has either underflowed, or overflowed.
- If the user selects **MASKED**, no alarm will be generated.

## CONFIG: MASK: RX-IF

```
RXIF:   AGC = ACTIVE (ACTIVE, MASK)  
        EbNo = MASKED (ACTIVE, MASK)
```

Use the [←] [→] arrow keys to select the parameter to edit: **AGC** or **EbNo**. Select either **ACTIVE** or **MASKED**, using the [↑] [↓] arrow keys, then press ENTER.

- If the user selects **ACTIVE**, then an **AGC** will be generated whenever the receive signal level exceeds  $-20$  dBm (for the desired carrier). An **Eb/No** fault will be generated whenever the demodulator sees the receive **Eb/No** fall below the pre-determined value.
- If the user selects **MASKED**, no alarm will be generated.

## CONFIG: MASK: SATELLITE ALARMS

```
SATELLITE ALARMS  
TRANSMIT      RECEIVE
```

Select either **TX** or **RX**, using the [←][→] arrow keys, then press ENTER.

## CONFIG: MASK: SATELLITE ALARMS: TX

```
PROCESS ALARMS FROM (H/W, S/W, OFF)  
BWA1=OFF   BWA2=OFF   BWA3=S/W   BWA4=H/W
```

Select the **Backward Alarm (BWA)** to be edited using the [←][→] arrow keys. Edit the settings using the [↑] [↓] arrow keys, then press ENTER. Select how the **TX IDR**

backward alarm inputs are to be used. An activated alarm may respond to a hardware input at **P5A (H/W)** or be software controlled by a receive fault on the modem (**S/W**).

### CONFIG: MASK: SATELLITE ALARMS: RX

```
PROCESS ALARMS RECEIVED FROM SATELLITE  
BWA1=N, BWA2=N, BWA3=N, BWA4=N
```

Select which Receive IDR backward alarms are to be monitored.

### CONFIG: MASK: TERR-ALM

```
TERR-ALM: TX = ACTIVE (ACTIVE, MASK)  
           RX = OFF (OFF, ENABLED)
```

These alarms are only valid for D&I operation.

Use the [**←**] [**→**] arrow keys to select the parameter to edit. Edit the alarms using the [**↑**] [**↓**] arrow keys, then press ENTER.

---

#### 6.3.1.11 CONFIG: IMPEDANCE

```
IF IMPEDANCE = 50 (50, 75 OHMS)
```

Select either **50** or **75Ω**, using the [**↑**] [**↓**] arrow keys, then press ENTER. Note that this affects both the Rx and Tx IF ports simultaneously.

---

#### 6.3.1.12 CONFIG: STATISTICS

```
LINK STATISTICS LOGGING INTERVAL:  
00 minutes (00 TO 90)
```

Edit the logging interval (the period of time over which the statistics will be measured), using the [**↑**] [**↓**] arrow keys, then press ENTER. Setting a value of 00 disables the feature (no logging).

The user can choose 00, 10, 20, 30, 40, 50, 60, 70, 80, or 90 minutes. For more information about the Statistics data taken, refer to Section 6.3.4.3 Monitor: Statistics.

## 6.3.2 TEST

**MODEM TEST MODE = NORMAL**  
(**NORM, TX-CW, TX-1/0, IF↓, RF↓, DIG↓, I/O↓**)

Select **TEST Mode** or **Normal Operation** from the parameters shown in the parentheses using the [↑] [↓] arrow keys, then press ENTER.

This sub-menu permits the user to select the following test modes:

<b>NORM</b>	<i>(Normal) This clears any test modes or loopbacks, and places the unit back into an operational state.</i>
<b>TX-CW</b>	<i>(Transmit CW) This is a test mode, which forces the modulator to transmit a pure carrier (unmodulated).</i>
<b>TX-1,0</b>	<i>(Transmit an alternating 1,0,1,0 pattern) This is a test mode, which forces the modulator to transmit a carrier modulated with an alternating 1,0,1,0 pattern, at the currently selected symbol rate. This causes two discrete spectral lines to appear, spaced at +/- half the symbol rate, about the carrier frequency. This mode is used to check the carrier suppression of the Modulator.</i>
<b>IF LOOP</b>	<i>(IF Loopback) This test mode invokes an internal IF loop. This is a particularly useful feature, as it permits the user to perform a quick diagnostic test without having to disturb external cabling. Furthermore, all of the receive configuration parameters are temporarily changed to match those of the transmit side. When NORMAL is again selected, all of the previous values are restored.</i>
<b>DIG LOOP</b>	<i>(Digital Loopback) This test mode invokes a digital loopback, which loops data at the output of the Reed-Solomon encoder on the transmit side, back into the Reed-Solomon decoder on the receive side. This tests all of the interface, transmit baseband circuits, FEC encoder, FEC decoder, and buffer.</i>
<b>I/O LOOP</b>	<i>(Inward/Outward loopback) This test mode invokes two distinct loopbacks. The first of these is the inward loop, which takes data being received from the satellite direction, and passes it directly to the modulator. Simultaneously, the outward loop is invoked, whereby data being fed to the transmit data interface is routed directly back out of the receive data interface.</i>
<b>RF LOOP</b>	<i>(RF Loopback) This test mode is almost identical to the IF loop mode. All of the receive configuration parameters (except Rx Spectrum Invert) are temporarily changed to match those of the transmit side, however, no internal connection is made. This is useful for performing a satellite loopback. When NORMAL is again selected, all of the previous values are restored.</i>

The IF, Digital, and I/O Loopback modes are illustrated in Figure 6-1.



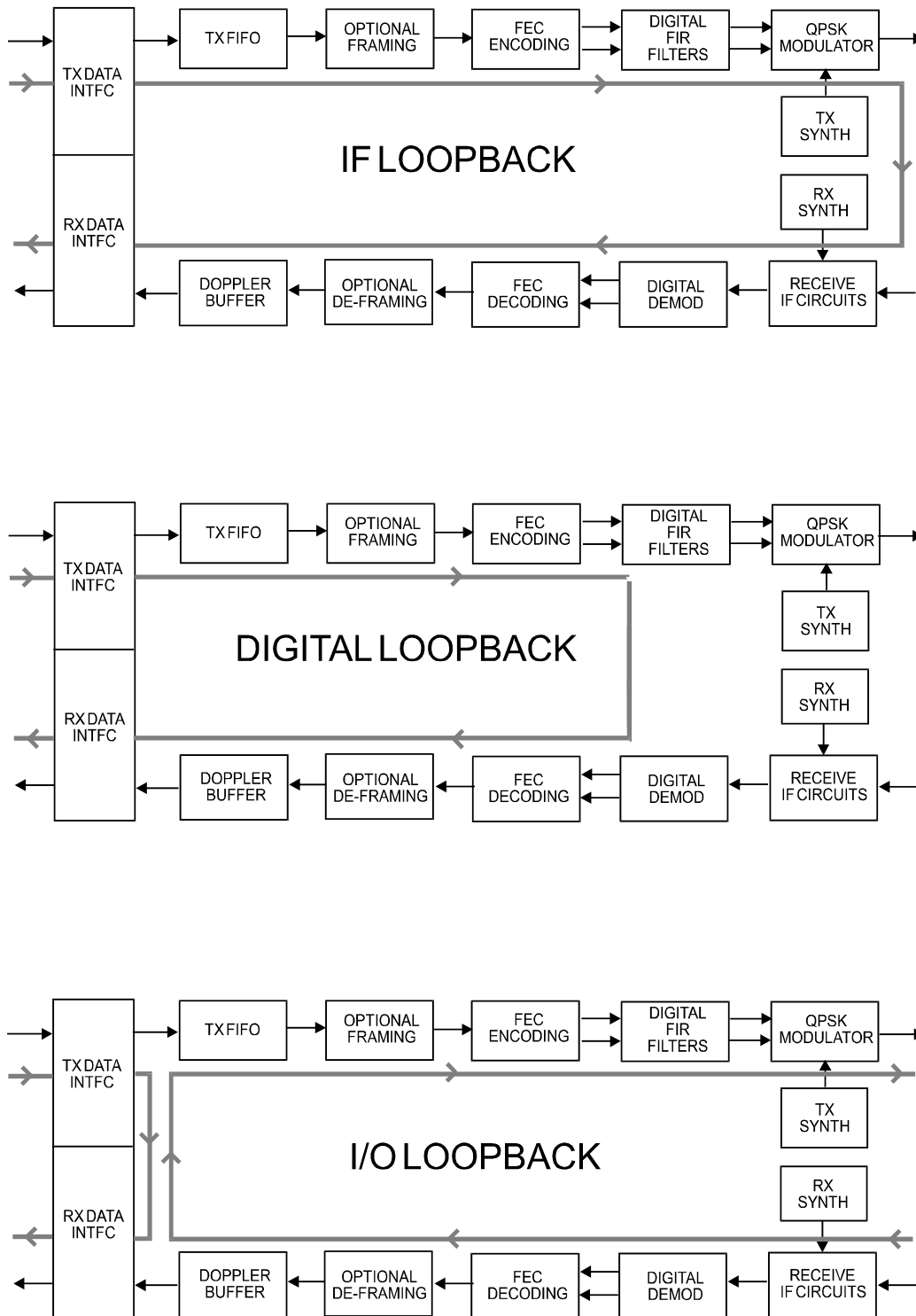

Figure 6-4. Loopback Modes

### 6.3.3 INFORMATION

```
INFO: ALL ID FORMAT TX RX CLOCKS EDMAC  
DROP INSERT REMOTE ALARM-MASK MISC
```

Select information to view using the [←][→] arrow keys, then press ENTER.

**Note:** INFO screens display information on the current configuration of the modem without risking inadvertent changes.

#### INFO:ALL

```
ALL = START  
(STOP, START)
```

This menu permits the user to view the configuration of the unit, in a step-by-step process by scrolling through each menu in succession. Press ENTER to continue through all the configurations.

Note that the user may only *view* the configurations – *no editing is possible*.

Press CLEAR to discontinue.

#### INFO: ID

```
MODEM CIRCUIT ID:  
----A TEST MESSAGE TO SHOW CIRCUIT ID----
```

This displays the user-defined Circuit ID string (40 characters), which is entered via the UTILITY, ID screen. To return to the previous menu, press ENTER.

#### INFO: MODE

```
INFO:  MODE:  TX = G.703B: DROP  (B8ZS)  
                RX = G.703B: INSERT (B8ZS)
```

An example of a Mode Information screen is shown above.

## INFO: TX

```
TX:ON 070.00000MHz Z=50 PWR=-20.0 TSI=N
VIT+RS:220/200 00604.000 QPSK 7/8 SCRM
```

A sample display of TX Info is shown. The information displayed here is as follows:

<b>Top Line:</b>	
TX carrier	ON, OFF, or RTI
TX Frequency	xxxxx.xxx MHz
Impedance	50 or 75 $\Omega$
Power	Power Level (dB)
TSI	TSI = TX Spectral Inversion, I=Inverted (on), N=Not inverted (off)
<b>Bottom line:</b>	
Encoder	FEC type: VITERBI, SEQ, TCM, VIT+RS, SEQ+RS, TCM+RS, TPC, LDPC NONE: x (x = Differential Encoder setting, shown as DE-OFF or DE-ON)
Data Rate	xxxxx.xxx kbps (an asterix * indicates that the data sense is inverted)
Modulation	BPSK, QPSK, OQPSK, 8-PSK, 8-QAM, 16-QAM
FEC rate	1/2, 2/3, 3/4, 7/8, 0.95, 5/16, 21/44 or 1/1
Scrambler	SCRM, NONE, or IESS (Turbo Only)

## INFO: RX

```
RX:070.00000MHz Z=50 02.0dB +-30 RSI=N
VIT+RS:126/112 00604.000 QPSK 1/2 SCRM
```

A sample display of RX Info is shown. The information displayed here is as follows:

<b>Top line:</b>	
RX Frequency	XXXXX.XXX MHz
Impedance	50 or 75 $\Omega$
Eb/No	12 dB (Alarm Point)
Sweep Range	up to $\pm$ 32 kHz
RSI	RSI = RX Spectral Inversion, I=Inverted (on), N=Not inverted (off)
<b>Bottom line:</b>	
Decoder	FEC type: VITERBI, SEQ, TCM, VIT+RS, SEQ+RS, TCM+RS, TPC, LDPC NONE: x (x = Differential Encoder setting, , shown as DE-OFF or DE-ON)
Data Rate	xxxxx.xxx kbps (an asterix * indicates that the data sense is inverted)
Demodulation	BPSK, QPSK, OQPSK, 8-PSK, 8-QAM, 16-QAM
FEC rate	1/2, 2/3, 3/4, 7/8, 0.95, 5/16, 21/44 or 1/1
Descrambler	SCRM, NONE, or IESS (Turbo Only)

## INFO: CLOCKS

```
CLOCKS:TX=INT(SCT)RX=EXT-CLK REF=INT10  
BUFFER-SIZE=00016 CLK=02048U
```

The TX Clock, RX Clock and Buffer information is displayed.

**Note:** The Clock (CLK) information is shown only if Rx Clock is set to EXT-CLK.

## INFO: EDMAC

```
EDMAC FUNCTION= ON  
EDMAC MODE= MASTER      EDMAC ADDR= 0020
```

This screen shows if EDMAC is enabled or not. If it is enabled, the EDMAC Mode and Address are shown.

## INFO: DROP TYPE

```
DROP TYPE=      CH:1  
E1-CCS         TS:01
```

This screen shows the Drop Type. Pressing ENTER takes the user back to the previous menu.

## INFO: INSERT TYPE

```
INSERT TYPE=    CH:1  
E1-CCS         TS:01
```

This screen shows the Insert Type. Pressing ENTER takes the user back to the previous menu.

## INFO: REMOTE

```
REMOTE-CONTROL= LOCAL  ADDRESS= 0000  
INTERFACE = RS-232    9600 BAUD N81
```

This screen shows if the unit is in Local or Remote mode, provides the details of the electrical interface type selected, the unit's address and the baud rate selected. Pressing ENTER takes the user back to the previous menu.

## INFO: ALARMS MASK

```
ALARMS MASKED: TX-AIS  RX-AIS  BUF-SLIP  
                AGC    EBNO  SAT
```

This screen shows only the alarm(s) that are currently **masked**:

- TX-AIS
- RX-AIS
- BUF-SLIP
- AGC
- EBNO
- SAT
- TERR

If an alarm is not masked, a blank is displayed in the relevant screen position.

## INFO: MISC

```
MISCELLANEOUS:  NORMAL  
1:1 SWITCH = NOT CONNECTED  ONLINE
```

This screen shows the following:

- Test Mode
- 1:1 Link Status
- Redundancy Status

### 6.3.4 MONITOR

```
MONITOR: LIVE-ALARMS  STORED-EVENTS
STATISTICS  RX-PARAMS  AUPC-PARAMS
```

Select the parameter to Monitor using the [←][→] arrow keys, then press ENTER.

#### MONITOR: LIVE-ALARMS

```
LIVE      UNIT= NONE      NET= NONE
ALARMS    RECV=DEMODO LOCK XMT= NONE
```

An example of an Alarm screen is shown. The **highest** priority alarm currently active for each of the four alarm types is shown:

<b>Unit</b>	<p><b>PSU:</b> Power supplies (+5V, +12V, -5V, +18V, -12V) are always monitored by an onboard supervisory IC.</p> <p><b>TX and RX SYNTH:</b> The PLLs in the IF sections are monitored for an unlocked condition.</p> <p><b>POWER CAL:</b> Calibration data stored in EEPROM is checked at power up to verify that the factory calibration has not been corrupted.</p> <p><b>FPGA</b> downloads (Main chain, Turbo FEC, Modem “Top” card, Mux and Demux) are verified to have been loaded successfully.</p> <p><b>Hi-Stab Freq Ref Module:</b> No PLL Lock – This will suppress the TX carrier.</p>
<b>Transmit</b>	<p><b>NO CLOCK:</b> Clock activity from the Tx terrestrial source is checked, if expected. If absent, the modem falls back to the internal SCT clock to drive the modulator.</p> <p><b>FIFO SLIP:</b> alarm occurs when the terrestrial clock source differs from the programmed data rate, or may indicate a hardware failure.</p> <p><b>TX AIS:</b> Alarm Indication Signal (all 1’s) present at the Tx terrestrial input is monitored.</p> <p><b>AUPC LEVEL:</b> If AUPC is enabled, a Tx alarm occurs if the power increase limit has been reached.</p> <p><b>Hi-Stab Freq Ref Module:</b> Ref Activity Fault</p>
<b>Receive</b>	<p><b>DEMODO LOCK:</b> indicates either the demodulator or the following FEC decoder cannot lock to the incoming signal.</p> <p><b>AGC ALARM:</b> is indicated if the demod signal level is &gt;-20 or &lt;-60 dBm.</p> <p><b>FRAME SYNC:</b> indicates that the de-framing unit (EDMAC, IBS or IDR) or Reed-Solomon outer decoder cannot synchronize to the data being sent to it by the demod and/or FEC decoder.</p> <p><b>BUFF SLIP:</b> occurs when Doppler or Plesiochronous effects cause the Rx data buffer to empty or fill completely. The results in a reset to 50%.</p> <p><b>RX AIS:</b> Alarm Indication Signal (all 1’s) present at the Rx satellite input is monitored.</p> <p><b>EbNo ALARM:</b> occurs when the monitored level drops below that programmed by the user in the CONFIG, RX, EbNo menu.</p> <p><b>BUFF CLOCK:</b> indicates that the desired buffer reference is not present, causing the buffer to fall back on Rx satellite timing to clock its output.</p>

<b>Unit Network</b>	<p><b>LOSE TxFRM:</b> Loss of Tx frame occurs in Drop &amp; Insert operation, when the incoming T1 or E1 frame cannot be found by the modem.</p> <p><b>BER &gt;10E-3:</b> This error rate monitor is enabled for IBS and IDR framing.</p> <p><b>LOSE TxMUL:</b> Loss of Tx multiframe occurs in E1-CAS D&amp;I operation, when the multiframe marker for CAS signaling data cannot be found.</p> <p><b>Tx Sig AIS:</b> An AIS condition in the signaling positions of an incoming E1-CAS frame is monitored.</p> <p><b>TX TERR RM</b> indicates the presence of the Tx terrestrial remote alarm on the incoming T1 or E1 frame.</p> <p><b>IBS RX REM</b> indicates the presence of the IBS satellite remote alarm (backward alarm) on the incoming IBS frame from the transmit side of the link.</p> <p><b>IDR RX BW1-4:</b> Multi-destinational backward alarms are the corresponding satellite alarms used by the IDR frame structure.</p> <p><b>IDR TX BW1-4:</b> Backward alarms 1-4 indicate that the hardware inputs available on the back panel of the modem have triggered, resulting in the corresponding Tx backward alarm being generated by the modem's IDR framer.</p>
-------------------------	---

---

### 6.3.4.1 MONITOR: STORED EVENTS

```

STORED EVENTS:  CLEAR ALL: NO  (NO,YES)
#199 FT-FRAME SYNC      23/07/01 16:25:24
    
```

An example of a Stored Events screen is shown. Use the [↑] [↓] arrow keys to select Clear All: YES or NO, then press ENTER.

Use the [←][→] arrow keys to select the ‘#’ character on the bottom line to view the log entries. Scroll backwards or forwards through the entries in the event log, using the [↑] [↓] arrow keys. Pressing ENTER or CLEAR will take the user back to the previous menu. The event log can store up to 199 events. When a fault condition occurs, it is time-stamped and put into the log. Similarly, when the fault condition clears, this is also recorded.

If the user selects CLEAR ALL, the event log is cleared, and the user is taken directly back to the previous menu. However, if there are faults present on the unit at this time, they will be re-time-stamped, and new log entries will be generated.

Note that in accordance with international convention, the date is shown in DAY-MONTH-YEAR format.

### 6.3.4.2 MONITOR: STATISTICS

```
STATISTICS: STA114: 16.0,16.0,9.0,9.0
09/12/99 14:48:06 CLEAR ALL: NO (N/Y)
```

The user may scroll backwards or forwards through the entries in the statistics log, using the [↑] [↓] arrow keys. Pressing ENTER or CLEAR will take the user back to the previous menu. The top line displays the log entry number and event log. The bottom line of the display indicates the time and date of the entry shown in DAY-MONTH-YEAR format. The display shows the statistics data that has been measured and recorded. The statistics log can store up to 199 log entries. (To enable statistics logging, see Section 6.3.1.12.)

The meaning and format of the numbers is as follows:

- The user defines a measurement interval (see CONFIG, STATS) and during this interval, Eb/No and Transmit Power Level Increase (TPLI) are observed, at a 1 second rate.
- At the end of this period, the average Eb/No is calculated and recorded, and the minimum value seen in the interval.
- Similarly, the average TPLI is calculated, along with the highest value seen in the interval.



***If the demod has lost lock during the measurement interval, the minimum Eb/No will show 'LOSS' rather than indicate a value. However, the average value (while the demod was locked) will still be calculated and shown. If, on the other hand, the demodulator has been unlocked for the entire measurement interval, the average Eb/No will also show 'LOSS'. (The display will show 'LOSS,LOSS'.)***

- If the measured values are  $\geq 16.0$  dB, the display will show 16.0 dB.
- If AUPC is not enabled, the values of maximum and average TPLI will both show '0.0'.

**Example:** 08.0,13.5,2.5,1.8 means:  
Minimum Eb/No observed in the measurement interval = 8.0 dB  
Average Eb/No observed in the measurement interval = 13.5 dB  
Maximum TPLI observed in the measurement interval = 2.5 dB  
Average TPLI observed in the measurement interval = 1.8 dB

**Example:** LOSS,04.5,0.0,0.0 means:  
There was a loss of demod lock during the measurement interval  
Average Eb/No observed in the measurement interval = 4.5 dB  
Maximum TPLI observed in the measurement interval = 0 dB  
Average TPLI observed in the measurement interval = 0 dB (Which indicates no AUPC activity, or that AUPC is disabled.)

Use the [←] or [→] arrow keys to select the CLEAR ALL option. Select Yes or No using the [↑] or [↓] arrow keys and press ENTER to implement, or CLEAR.



---

### 6.3.4.3 MONITOR: RX PARAMETERS

```
RX=PARAMETERS: EbNo=11.4dB   ΔF=+11.7kHz  
BER=0.0E-9   BUFFER=51%   RX-LEVEL=-43dBm
```

If the demodulator is locked, this screen shows the following:

<b>Eb/No</b>	This shows the value of Eb/No calculated by the demodulator. The value referred to here is the energy per information bit (E <sub>b</sub> ), divided by the noise spectral density (N <sub>o</sub> ).
<b>ΔF</b>	The frequency offset of the received carrier, in kHz, with a displayed resolution of 100 Hz.
<b>BER</b>	This is an estimate of the corrected BER.
<b>BUFFER</b>	(Buffer fill state) This shows the fill state (in percent), of the receive Buffer. After a reset, it will read 50. A value <50 indicates that the buffer is emptying, and >50 indicates that it is filling.
<b>RX-LEVEL</b>	A dBm reading indicating the signal level of the desired receive carrier.

---

### 6.3.4.4 MONITOR: AUPC-PARAMS

```
AUPC-PARAMS:  REMOTE EbNo=6.8dB  
TRANSMIT POWER INCREASE=1.2dB
```

The top line displays the value of Remote Eb/No of the demodulator at the distant end of the satellite link. The Remote Eb/No will display UNLOCK if the remote DEMOD is unlocked. The bottom line shows how much the AUPC system has increased the output power. If AUPC is not enabled, the value of TX POWER INCREASE will show as 0.0 dB.

### 6.3.5 STORE/LOAD

```
CONFIGURATION: 0 LOAD STORE  
'AVAILABLE'
```

Select LOAD, STORE or EDIT using the [←][→] arrow keys, then press ENTER.

The user can store, load up to 10 different modem configurations, or record the date and time of stored configurations in the non-volatile memory of the modem. These configurations can be viewed using the [↑] [↓] arrow keys, and their names edited.

---

### 6.3.5.1 STORE/LOAD: OVERRIDE CONFIGURATION

```
CONFIGURATION: xx OVERRIDE: NO (YES/NO)
```

Select override using the [↑] [↓] arrow keys, then press ENTER.

### 6.3.6 UTILITIES

```
UTILITIES: SET-RTC DISPLAY-BRIGHTNESS  
LAMP 1:1-MANUAL-SWITCH EDIT-CIRCUIT-ID
```

Select the Utilities parameter using the [←][→] arrow keys, then press ENTER.

---

#### 6.3.6.1 UTILITIES: SET-RTC

```
EDIT REAL-TIME CLOCK:  
TIME: 12:00:00 DATE: 24/04/01
```

To edit the time and date settings of the REAL-TIME CLOCK, select the digit to be edited using the [←][→] arrow keys, change the value of the digit using the [↑] [↓] arrow keys, then press ENTER.



*Note that in accordance with international convention, the date is shown in DAY-MONTH-YEAR format.*

---

#### 6.3.6.2 UTILITIES: BRIGHTNESS

```
EDIT DISPLAY BRIGHTNESS: 100%
```

To edit the display BRIGHTNESS, use the [↑] [↓] arrow keys. Press ENTER when the brightness is suitable. Note that the values of brightness that can be selected are 25%, 50%, 75% or 100%.

---

### 6.3.6.3 UTILITIES: LAMP

```
FRONT PANEL LAMP TEST: XXXXXXXX
```

Select enable or disable, using the [↑][↓] arrow keys, then press ENTER.  
This will test all of the LEDs on the front panel then resume normal operations.

---

### 6.3.6.4 UTILITIES: 1:1 MANUAL SWITCH

```
PRESS ENTER KEY TO FORCE UNIT INTO  
STANDBY (1:1 ONLY)
```

If the unit is part of a 1:1 redundant pair of modems, and this unit, is currently on-line, pressing ENTER will cause the unit to switch to standby.

---

### 6.3.6.5 UTILITIES: CIRCUIT ID

```
EDIT THIS MODEM'S CIRCUIT ID:  
-----
```

Edit the Circuit ID string, using the [←][→] and [↑][↓] arrow keys. Only the bottom line is available (40 characters). Use the [←][→] arrow keys to position the cursor on to the character to be edited. Edit the character using [↑][↓] arrow keys. The following characters are available:

Space ( ) \* + - , . / 0-9 and A-Z.

When the user has composed the string, press ENTER.

### 6.3.7 ODU

This permits the CDM-600 to interface directly with a Comtech RF Transceiver (Outdoor Unit, or ODU). This is accomplished using a low-speed, half-duplex FSK link on the Rx IF port, with a carrier frequency around 2.7 MHz.

```
ODU CONTROL=DISABLE (DISABLE, ENABLE)
SYSTEM TYPE=STANDALONE (STANDALONE, 1:1)
```

### 6.3.8 FAST

```
FAST OPTIONS: SET VIEW
MOTHERBOARD S/N 123456789 HW REV 1.0
```

Select whether to change or view current settings using [←][→] arrow keys.

---

#### 6.3.8.1 FAST: SET

```
ENTER 20 CHAR CODE BELOW AND PRESS ENTER
XXXXXXXXXXXXXXXXXXXXXXXX
```

FAST is the way to enable new options in the modem. Obtain the FAST code for the new option from Comtech EF Data. Enter the code carefully. Use the [←][→] arrow keys to move the cursor to each character. Use the [↑][↓] arrow keys to edit the character, then press ENTER. The modem will respond with “Configured Successfully” if the new FAST option has been accepted.

---

#### 6.3.8.2 FAST: VIEW

```
VIEW OPTIONS:          10 9 8 7 6 5 4 3 2 1
20 Mbps                INSTALLED
```

Use the [←][→] arrow keys to show which FAST options are currently installed.

# Chapter 7. FORWARD ERROR CORRECTION OPTIONS

---

## 7.1 Introduction

As standard, the CDM-600 Modem is equipped with four Forward Error Correction encoders/decoders – Viterbi, Sequential, concatenated Reed-Solomon and Trellis (which is available with the 8-PSK FAST option). The constraint lengths and encoding polynomials are not only Open Network compatible, but are also Closed Network compatible with the vast majority of existing modems from other manufacturers. Comtech EF Data has performed compatibility testing to ensure inter-operability.

Turbo Coding represents a very significant development in the area of FEC, and optionally, the CDM-600 may be fitted with one of two Turbo Product Codecs They are plug-in daughter cards (SIMM modules), both field upgradeable. The Low Rate option provides data rate capability up to 5 Mbps, and code rates limited to Rate 5/16 (BPSK, Rate 21/44 (BPSK) and Rate 3/4 (QPSK, OQPSK, 8-PSK and 16-QAM). The High Rate option provides data rate capability up to 20 Mbps, in addition to Rate 7/8 and Rate 0.95 capability.

Now, Low-Density Parity Check (**LDPC**) coding is being offered in addition to the TPC options. In some instances this provides even better performance than TPC. A third option card, again field upgradeable, combines LDPC and TPC together on one module. This provides the best Forward Error Correction technology currently available, and is offered with a sufficient range of code rates and modulation types that link performance can be optimized under any conditions.

---

## 7.2 Viterbi

The combination of convolutional coding and Viterbi decoding has become an almost universal standard for satellite communications. The CDM-600 complies with the Intelsat

IESS 308/309 standards for Viterbi decoding with a constraint length of seven. This is a *de facto* standard, even in a closed network environment, which means almost guaranteed interoperability with other manufacturer's equipment. It provides very useful levels of coding gain, and its short decoding delay and error-burst characteristics make it particularly suitable for low data rate coded voice applications. It has a short constraint length, fixed at 7, for all code rates. (The constraint length is defined as the number of output symbols from the encoder that are affected by a single input bit.) By choosing various coding rates (Rate 1/2, 3/4 or 7/8) the user can trade off coding gain for bandwidth expansion. Rate 1/2 coding gives the best improvement in error rate, but doubles the transmitted data rate, and hence doubles the occupied bandwidth of the signal. Rate 7/8 coding, at the other extreme, provides the most modest improvement in performance, but only expands the transmitted bandwidth by 14 %. A major advantage of the Viterbi decoding method is that the performance is independent of data rate, and does not display a pronounced threshold effect (i.e., does not fail rapidly below a certain value of Eb/No). This is not true of the Sequential decoding method, as explained in the section below. Note that in BPSK mode, the CDM-600 only permits a coding rate of 1/2. Because the method of convolutional coding used with Viterbi, the encoder does not preserve the original data intact, and is called *non-systematic*.

**Table 7-1. Viterbi Decoding Summary**

FOR	AGAINST
Good BER performance - very useful coding gain.	Higher coding gain possible with other methods
Almost universally used, with <i>de facto</i> standards for constraint length and coding polynomials	
Shortest decoding delay (~100 bits) of any FEC scheme - good for coded voice, VOIP, etc	
Short constraint length produce small error bursts - good for coded voice.	
No pronounced threshold effect - fails gracefully.	
Coding gain independent of data rate.	

---

### 7.3 Sequential

Although the method of convolutional coding and Sequential decoding appears to be very similar to the Viterbi method, there are some fundamental differences. To begin with, the convolutional encoder is said to be *systematic* - it does not alter the input data, and the FEC overhead bits are simply appended to the data. Furthermore, the constraint length, k, is much longer (Rate 1/2, k=36. Rate 3/4, k= 63. Rate 7/8, k=87). This means that when the decoding process fails (that is, when its capacity to correct errors is exceeded) it produces a burst of errors which is in multiples of half the constraint length. An error distribution is produced which is markedly different to that of a Viterbi decoder. This gives rise to a pronounced threshold effect. A Sequential decoder does not fail gracefully - a reduction in Eb/No of just a few tenths of a dB can make the difference between acceptable BER and a complete loss of synchronization. The decoding algorithm itself (called the Fano algorithm) uses significantly more path memory (4 kbps in this case) than the equivalent Viterbi decoder, giving rise to increased latency. Furthermore, a fixed computational clock is used to process input symbols, and to search backwards and forwards in time to determine the correct decoding path. At

lower data rates there are sufficient number of computational cycles per input symbol to permit the decoding process to perform optimally. However, as the data rate increases, there are fewer cycles available, leading to a reduction in coding gain. This is clearly illustrated in the performance curves that follow. For data rates above ~1 Mbps, Viterbi should be considered the better alternative. The practical upper limit at this time is 2.048 Mbps.

**Table 7-2. Sequential Decoding Summary**

FOR	AGAINST
Higher coding gain (1-2 dB) at lower data rates, compared to Viterbi.	Pronounced threshold effect - does not fail gracefully in poor Eb/No conditions.
	Higher processing delay than Viterbi (~4 k bits) - not good for low-rate coded voice.
	Upper data rate limit approximately 2Mbps
	Coding gain varies with data rate - favors lower data rates.

## 7.4 Reed-Solomon Outer Codec



**It cannot be emphasized strongly enough that the purpose of the concatenated Reed-Solomon is to dramatically improve the BER performance of a link under given noise conditions. It should NOT be considered as a method to reduce the link EIRP requirement to produce a given BER. Factors such as rain-fade margin, particularly at Ku-band, are extremely important, and reducing link EIRP can seriously degrade the availability of such a link.**

The concatenation of an outer Reed-Solomon (R-S) Codec with Viterbi decoder first became popular when it was introduced by Intelsat in the early 1990's. It permits significant improvements in error performance without significant bandwidth expansion. The coding overhead added by the R-S outer Codec is typically around 10%, which translates to a 0.4 dB power penalty for a given link. Reed-Solomon codes are block codes (as opposed to Viterbi and Sequential, which are convolutional), and in order to be processed correctly the data must be framed and de-framed. Additionally, R-S codes are limited in how well they can correct errors that occur in bursts. This, unfortunately, is the nature of the uncorrected errors from both Viterbi and Sequential decoders, which produce clusters of errors that are multiples of half the constraint length. (This is particularly severe in the case of Sequential, where the constraint lengths are considerably longer than Viterbi). For this reason, the data must be interleaved following R-S encoding, and is then de-interleaved prior to decoding. This ensures that a single burst of errors leaving the Viterbi or Sequential decoder is spread out over a number of interleaving frames, so errors entering the R-S decoder do not exceed its capacity to correct those errors. In the case of the CDM-600, different R-S code rates are used, according to the mode of operation:

## Closed Network Modes

A 220,200 code is used in transparent closed network modes, and a 200,180 code is used in framed (EDMAC) modes. (220,200 means that data is put into blocks of 220 bytes, of which 200 bytes are data, and 20 bytes are FEC overhead.) These two codes were chosen because they fit well into Comtech EF Data's clock generation scheme, and they have almost identical coding gain. There is also a 225, 205 code available that is compatible with legacy EF Data modems. When Viterbi decoding is used as the primary FEC, an interleaver depth of 4 is used. When Sequential decoding is used, an interleaver depth of 8 is used. The increase in coding gain is at the expense of delay. The interleaving/de-interleaving delay and the delay through the decoder itself can be as high as 25 kbps. At very low data rates, this equates to several seconds, making it highly unsuitable for voice applications. Additionally, the de-interleaver frame synchronization method can add significantly to the time taken for the demodulator to declare acquisition.

## Open Network Modes

### Code Rate Mode

219, 201 Standard IESS-308 E1, and IESS-310 mode  
225, 205 Standard IESS-308 T1  
194, 178 Standard IESS-308 T2/E2  
126, 112 Standard IESS-309 modes

A characteristic of concatenated R-S coding is the very pronounced threshold effect. For any given modem design, there will be a threshold value of  $E_b/N_0$  below which the demodulator cannot stay synchronized. This may be due to the carrier-recovery circuits, or the synchronization threshold of the primary FEC device, or both. In the CDM-600, and Rate 1/2 operation, this threshold is around 4 dB  $E_b/N_0$ . Below this value, operation is not possible, but above this value, the error performance of the concatenated R-S system produces exceptionally low error rates for a very small increase in  $E_b/N_0$ .



***Care should be taken not to operate the demodulator near its sync threshold. Small fluctuations in  $E_b/N_0$  may cause total loss of the link, with the subsequent need for the demodulator to re-acquire the signal.***

**Table 7-3. Concatenated RS Coding Summary**

FOR	AGAINST
Exceptionally good BER performance - several orders of magnitude improvement in link BER under given link conditions.	Very pronounced threshold effect - does not fail gracefully in poor $E_b/N_0$ conditions. Additional coding overhead actually degrades sync threshold, and reduces link fade margin.
Very small additional bandwidth expansion	Significant processing delay (~25 kbps) - not good for voice, or IP applications
	Adds to demod acquisition time.



## 7.5 Trellis Coding (FAST Option)

In the other FEC methods described here, the processes of coding and modulation are independent - the FEC codec has no knowledge of, or interaction with the modulator. However, there are schemes in which the coding and modulation are combined together, where the encoder places FEC symbols in a precise manner into the signal constellation. This can yield an overall improvement in performance, and is used in higher-order modulation schemes, such as 8-PSK, 16-PSK, 16-QAM, etc. When convolution coding is used, the overall *coded modulation* approach is referred to as Trellis Coded Modulation (TCM). Ungerboeck was an early pioneer, and developed optimum mapping and decoding schemes. However, the decoding scheme was seen as complex, and expensive, and Qualcomm Inc. developed a variation on the theme, which uses a Viterbi decoder at the core, surrounded by adjunct processing. The scheme is able to achieve performance very close to the optimum Ungerboeck method, but with far less complexity, and is called *pragmatic Trellis Coded Modulation*.

Now, Intelsat recognized that, as more and more high power transponders are put in to service, the transponders are no longer *power limited*, but *bandwidth limited*. In order to maximize transponder capacity, they looked at 8-PSK as a method of reducing the occupied bandwidth of a carrier, and adopted Qualcomm's pragmatic TCM, at Rate 2/3.

A Rate 2/3 8-PSK/TCM carrier occupies only 50% of the bandwidth of a Rate 1/2 QPSK carrier. However, the overall coding gain of the scheme is not adequate by itself, and so Intelsat's IESS-310 specification requires that the scheme be concatenated with an outer RS codec. When combined, there is a threshold value of  $E_b/N_0$  of around 6 dB, and above approximately 7 dB, the bit error rate is better than  $1 \times 10^{-8}$ .

The detractions of the concatenated RS approach apply here also, along with more stringent requirements for phase noise and group delay distortion – the natural consequences of the higher-order modulation.

The CDM-600 fully implements the IESS-310 specification at data rates up to 20 Mbps. In accordance with the specification, the R-S outer code can be disabled. Performance curves for both cases are shown in the following Figures.

**Table 7-4. 8-PSK/TCM Coding Summary**

FOR	AGAINST
Exceptionally bandwidth efficient compared to QPSK	Needs concatenated RS outer codec to give acceptable coding gain performance
	Demod acquisition threshold much higher than for QPSK
	8-PSK is more sensitive to phase noise and group delay distortion than QPSK

---

## 7.6 Turbo Product Codec (Hardware Option)

Turbo coding is an FEC technique developed within the last few years, which delivers significant performance improvements compared to more traditional techniques. Two general classes of Turbo Codes have been developed, Turbo Convolutional Codes (TCC), and Turbo Product Codes (TPC, a block coding technique). Comtech EF Data has chosen to implement an FEC codec based on TPC. A Turbo Product Code is a 2 or 3 dimensional array of block codes. Encoding is relatively straightforward, but decoding is a very complex process requiring multiple iterations of processing for maximum performance to be achieved.

Unlike the popular method of concatenating a R-S codec with a primary FEC codec, Turbo Product Coding is an entirely stand-alone method. It does not require the complex interleaving/de-interleaving of the R-S approach, and consequently, decoding delays are significantly reduced. Furthermore, the traditional concatenated R-S schemes exhibit a very pronounced threshold effect – a small reduction in Eb/No can result in total loss of demod and decoder synchronization. TPC does not suffer from this problem – the demod and decoder remain synchronized down to the point where the output error rate becomes unusable. This is considered to be a particularly advantageous characteristic in a fading environment. Typically, in QPSK, 8-PSK and 16-QAM TPC modes the demod and decoder can remain synchronized **2 – 3 dB below** the Viterbi/Reed-Solomon or TCM cases.

---

## 7.7 TPC and Low Density Parity Check (LDPC) coding

### 7.7.1 Introduction

In the past few years there has been an unprecedented resurgence in interest in Forward Error Correction (FEC) technology. The start of this new interest has its origins in the work done by Claude Berrou *et al*, and the landmark paper in 1993 - *Near Shannon Limit Error Correcting Coding and Decoding - Turbo Codes*. FEC is considered an essential component in all wireless and satellite communications in order to reduce the power and bandwidth requirements for reliable data transmission.

Claude Shannon, considered by many to be the father of modern communications theory, first established, in his 1948 paper *A Mathematical Theory of Communication*, the concept of Channel Capacity. This places an absolute limit on how fast it is possible to transmit error-free data within a channel of a given bandwidth, and with given noise conditions within that channel. He concluded that it would only be possible to approach this limit through the use of source encoding - what is familiar today as Forward Error Correction. He postulated that if it were possible to store every possible message in the receiver, finding the stored message that most closely matched the incoming message would yield an optimum decoding method. However, for all but the shortest bit sequences, the memory required for this, and the time taken to perform the comparisons, makes this approach impractical. For all practical purposes, the memory requirement and the decoding latency become infinite.

For many years there were few advances in the quest to approach the Shannon Limit. The Viterbi algorithm heralded a major step forward, followed in the early 1990s by the concatenation of a Viterbi decoder with Reed-Solomon hard-decision block codes. However,

it remained clear that the Shannon Limit was still an elusive target. Berrou's work on Turbo Codes showed, through the use of an ingeniously simple approach (multiple, or *iterative* decoding passes) that it is possible to achieve performance close to the Shannon Limit. Berrou's early work dealt exclusively with iteratively-decoded convolutional codes (Turbo Convolutional Coding, or TCC), but in time the iterative approach was applied to a particular class of block codes called Product Codes - hence Turbo Product Coding (TPC). TPC exhibits inherently low decoding latency compared with TCC, and so is considered much more desirable for 2-way, interactive satellite communications applications.

In August 1999, Comtech became the first company in the world to offer, on a commercial basis, satellite modems that incorporate TPC. Since its inception, Comtech has continued to develop and refine its implementation of TPC in its products, and now offers a comprehensive range of code rates (from Rate 5/16 to Rate 0.95) and modulations (from BPSK to 16-QAM). However, in the past few years, as part of the general interest in Turbo coding, a third class of Turbo coding has emerged, namely Low Density Parity Check Codes (LDPC). It is more like TPC than TCC, in that it is an iteratively-decoded block code. Gallager first suggested this in 1962, but at the time, the implementation complexity was considered to be too great, and for decades it remained of purely academic interest. Now, however, with silicon gates being cheap, plentiful and fast, an LDPC decoder can easily be accommodated in a large Field Programmable Gate Array (FPGA) device. Further interest in LDPC was stimulated in 2003, when the Digital Video Broadcasting (DVB) committee adopted LDPC codes (proposed by Hughes Network Systems) as the basis for the new DVB-S2 standard.

The LDPC method on its own produces an undesirable 'flaring' in the Bit Error Rate (BER) vs.  $E_b/N_0$  characteristic, and for this reason it is desirable to concatenate a short BCH code with LDPC. This concatenation produces almost vertical BER vs.  $E_b/N_0$  curves, as can be seen in the performance graphs that are presented later.

In order to take full advantage of the coding gain increase that LDPC provides, it became necessary to find an alternative to 8-PSK. Comtech EF Data has therefore developed an 8-QAM approach that permits acquisition and tracking at much lower values of  $E_b/N_0$  than 8-PSK. A discussion of this approach follows.

Comtech EF Data has chosen the CDM-600 platform as the first satellite modem in which to implement both LDPC and 8-QAM.

## 7.7.2 LDPC versus TPC

So, is LDPC better than TPC? The answer must be 'sometimes, but not always', and there are issues, such as latency, that must be taken into consideration. The graph shown below illustrates the performance of various TPC and LDPC modes relative to the Shannon Limit - the Channel Capacity is shown for both QPSK and 8-PSK. Error free transmission is not possible for values of spectral efficiency (capacity) vs.  $E_b/N_0$  above these limit curves. The horizontal distance to the limit provides a metric of overall performance.

It can be seen from this graph that for Code Rates above 3/4, Comtech's TPCs are very close (1 - 1.5 dB) to the Shannon Limit. However, at 3/4 and below, LDPCs are performing 0.7 - 1.2 dB better than TPCs.

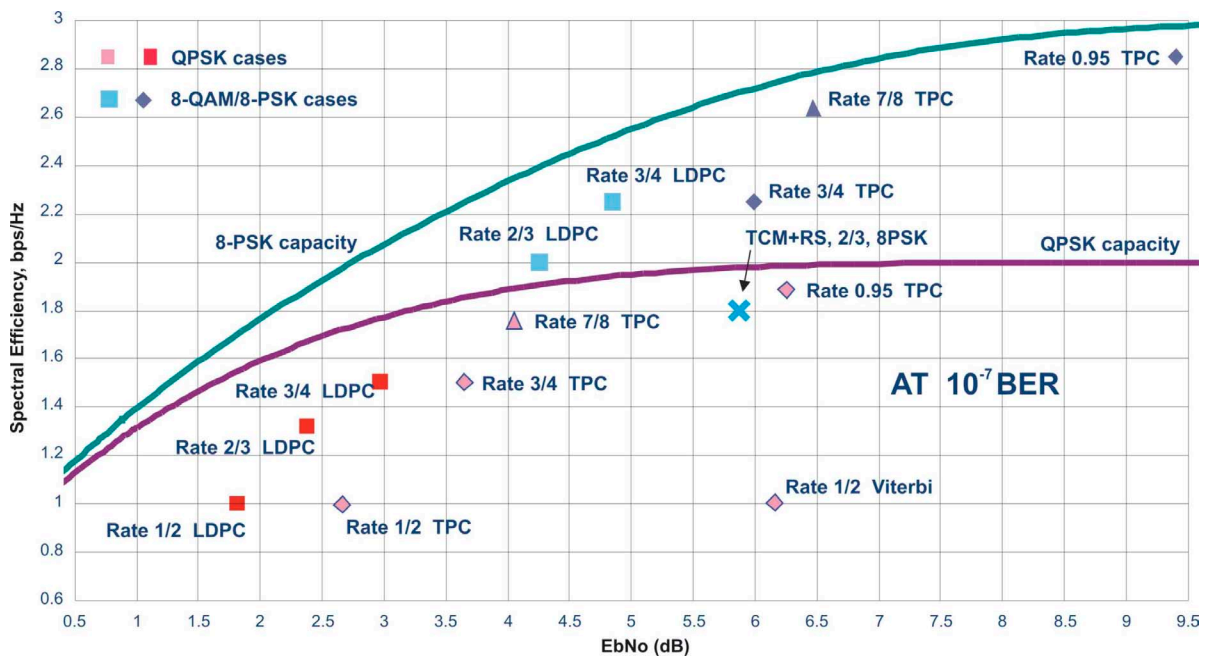

It is clear that in order to provide the best possible performance over the range of code rates from 1/2 to 0.95, both an LDPC and a TPC codec need to be offered.

In order to meet this requirement, Comtech EF Data has developed a combination LDPC/TPC Codec module that can be added to the CDM-600 Modem, and which provides the following operating modes:

**Table 7-5. Available TPC and LDPC Modes**

TPC Code Rate/Modulation	Data Rate Range
Rate 21/44 BPSK	4.8 kbps to 3.2 Mbps (to 4.772 Mbps with High Rate Turbo card)
Rate 5/16 BPSK	4.8 kbps to 2.048 Mbps (to 3.12 Mbps with High Rate Turbo card)
Rate 1/2 QPSK, OQPSK	4.8 kbps to 9.54 Mbps (High Rate Turbo card only)
Rate 3/4 QPSK, OQPSK	7.2 kbps to 5.0 Mbps (to 15 Mbps with High Rate Turbo card)
Rate 3/4 8-PSK	10.8 kbps to 5.0 Mbps (to 20 Mbps with High Rate Turbo card)
Rate 3/4 16-QAM	14.4 kbps to 5.0 Mbps (to 20 Mbps with High Rate Turbo card)
Rate 7/8 QPSK, OQPSK	8.4 kbps to 17.5 Mbps (High Rate Turbo card only)
Rate 7/8 8-PSK	12.6 kbps to 20 Mbps (High Rate Turbo card only)
Rate 7/8 16-QAM	16.8 kbps to 20 Mbps (High Rate Turbo card only)
Rate 0.95 QPSK, OQPSK	9.1 kbps to 18.888 Mbps (High Rate Turbo card only)
Rate 0.95 8-PSK	13.6 kbps to 20 Mbps (High Rate Turbo card only)
LDPC Code Rate/Modulation	Data Rate Range
Rate 1/2 BPSK	4.8 kbps to 5.0 Mbps (TPC/LDPC Codec card only)
Rate 1/2 QPSK, OQPSK	4.8 kbps to 10.0 Mbps (TPC/LDPC Codec card only)
Rate 2/3 QPSK, OQPSK	6.4 kbps to 13.3 Mbps (TPC/LDPC Codec card only)
Rate 2/3 8-PSK, 8-QAM	9.6 kbps to 19.0 Mbps (TPC/LDPC Codec card only)
Rate 3/4 QPSK, OQPSK	7.2 kbps to 15.0 Mbps (TPC/LDPC Codec card only)
Rate 3/4 8-PSK, 8-QAM	10.8 kbps to 20.0 Mbps (TPC/LDPC Codec card only)
Rate 3/4 16-QAM	14.4 kbps to 20.0 Mbps (TPC/LDPC Codec card only)

This new LDPC/TPC codec module may be installed in any existing CDM-600, as a simple field upgrade, or already installed in new modems ordered from the factory. It requires Firmware Version 1.6.0 (or higher) to be installed.

Please contact the Sales Department at Comtech EF Data for pricing and delivery information.

The table that follows compares all TPC and LDPC modes available in Comtech EF Data's CDM-600, and shows Eb/No performance and spectral efficiency (occupied bandwidth) for each case. This information will be of particular interest to satellite operators wishing to simultaneously balance transponder power and bandwidth. The large number of modes offered will permit, in the majority of cases, significant power and/or bandwidth savings when compared with existing schemes such as concatenated Viterbi/Reed-Solomon, or the popular 8-PSK/Trellis/Reed-Solomon (Intelsat IESS-310)

### 7.7.3 End-to-End Processing Delay

In many cases, FEC methods that provide increased coding gain do so at the expense of increased processing delay. However, with TPC, this increase in delay is very modest. Table 7-6 shows, for the CDM-600, the processing delays for the major FEC types, including the three TPC modes:

**Table 7-6. Turbo Product Coding Processing Delay Comparison**

FEC Mode (64 kbps data rate)	End-to-end delay, ms
Viterbi, Rate 1/2	12
Sequential, Rate 1/2	74
Viterbi Rate 1/2 + Reed Solomon	266
Sequential Rate 1/2 + Reed Solomon	522
Turbo Product Coding, Rate 3/4, O/QPSK	47
Turbo Product Coding, Rate 21/44, BPSK	64
Turbo Product Coding, Rate 5/16, BPSK	48
Turbo Product Coding, Rate 7/8, O/QPSK	245 *
Turbo Product Coding, Rate 0.95, O/QPSK	69
LDPC Coding, Rate 1/2	248
LDPC Coding, Rate 2/3, O/QPSK	296
LDPC Coding, Rate 2/3, 8-PSK, 8-QAM	350
LDPC Coding, Rate 3/4, O/QPSK	321
LDPC Coding, Rate 3/4, 8-PSK, 8-QAM, 16-QAM	395

Note that in all cases, the delay is inversely proportional to data rate, so for 128 kbps, the delay values would be half of those shown above. It can be seen that the concatenated Reed-Solomon cases increase the delay significantly (due mainly to interleaving/de-interleaving), while the TPC cases yield delays which are less than or equal to Sequential decoding.

\*A larger block is used for the Rate 7/8 code, which increases decoding delay.

Comparison of all Comtech EF Data TPC and LDPC Modes  
(CDM-600 with LDPC/TPC Codec and Firmware Version 1.6.0)

Mode	Eb/No at BER = 10 <sup>-6</sup> (typical)	Eb/No at BER = 10 <sup>-8</sup> (typical)	Spectral Efficiency (bps per Hertz)	Symbol Rate	Occupied * Bandwidth for 1 Mbps Carrier
<i>QPSK Rate 1/2 Viterbi *</i>	5.5 dB	6.8 dB	1.00 bps/Hz	1.0 x bit rate	1190 kHz
BPSK Rate 1/2 LDPC	1.7 dB	1.9 dB	0.50 bps/Hz	2.0 x bit rate	2380 kHz
BPSK Rate 21/44 TPC	2.6 dB	2.9 dB	0.48 bps/Hz	2.1 x bit rate	2493 kHz
BPSK Rate 5/16 TPC	2.1 dB	2.4 dB	0.31 bps/Hz	3.2 x bit rate	3808 kHz
QPSK/OQPSK Rate 1/2 LDPC	1.7 dB	1.9 dB	1.00 bps/Hz	1.0 x bit rate	1190 kHz
QPSK/OQPSK Rate 1/2 TPC	2.6 dB	2.8 dB	0.96 bps/Hz	1.05 x bit rate	1246 kHz
QPSK/OQPSK Rate 2/3 LDPC	2.1 dB	2.3 dB	1.33 bps/Hz	0.75 x bit rate	892 kHz
QPSK/OQPSK Rate 3/4 LDPC	2.7 dB	2.9 dB	1.50 bps/Hz	0.67 x bit rate	793 kHz
QPSK/OQPSK Rate 3/4 TPC	3.3 dB	4.0 dB	1.50 bps/Hz	0.67 x bit rate	793 kHz
QPSK/OQSK Rate 7/8 TPC	4.0 dB	4.2 dB	1.75 bps/Hz	0.57 x bit rate	678 kHz
QPSK/OQPSK Rate 0.95 TPC	6.0 dB	6.5 dB	1.90 bps/Hz	0.53 x bit rate	626 kHz
<i>8-PSK Rate 2/3 TCM ** and RS (IESS-310)</i>	5.6 dB	6.2 dB	1.82 bps/Hz	0.56 x bit rate	666 kHz
8-QAM Rate 2/3 LDPC	4.3 dB	4.5 dB	2.00 bps/Hz	0.50 x bit rate	595 kHz
8-QAM Rate 3/4 LDPC	4.7 dB	5.0 dB	2.25 bps/Hz	0.44 x bit rate	529 kHz
8-PSK Rate 3/4 TPC	5.7 dB	6.3 dB	2.25 bps/Hz	0.44 x bit rate	529 kHz
8-PSK Rate 7/8 TPC	6.6 dB	6.8 dB	2.62 bps/Hz	0.38 x bit rate	453 kHz
8-PSK Rate 0.95 TPC	8.9 dB	9.9 dB	2.85 bps/Hz	0.35 x bit rate	377 kHz
16-QAM Rate 3/4 LDPC	6.4 dB	6.6 dB	3.00 bps/Hz	0.33 x bit rate	396 kHz
16-QAM Rate 3/4 TPC	7.0 dB	7.7 dB	3.00 bps/Hz	0.33 x bit rate	396 kHz
16-QAM Rate 7/8 TPC	7.7 dB	7.9 dB	3.50 bps/Hz	0.28 x bit rate	340 kHz
<i>16-QAM Rate 3/4 ** Viterbi/Reed-Solomon</i>	7.5 dB	8.0 dB	2.73 bps/Hz	0.37 x bit rate	435 kHz
<i>16-QAM Rate 7/8 ** Viterbi/Reed-Solomon</i>	9.0 dB	9.5 dB	3.18 bps/Hz	0.31 x bit rate	374 kHz

\* The occupied bandwidth is defined as the width of the transmitted spectrum taken at the -10 dB points on the plot of power spectral density. This equates to 1.19 x symbol rate for the CDM-600 transmit filtering.

\*\* Included for comparative purposes

**Table 7-7. TPC and LDPC Summary**

<b>FOR</b>	<b>AGAINST</b>
Exceptionally good BER performance - significant improvement compared with every other FEC method in use today	Nothing!
Most modes have no pronounced threshold effect - fails gracefully	
Exceptional bandwidth efficiency	
Coding gain independent of data rate (in this implementation)	
Low decoding delay for TPC	
Easy field upgrade in CDM-600	

---

## 7.8 Uncoded Operation (No FEC)

There are occasions where a user may wish to operate a satellite link with no forward error correction of any kind. For this reason, the CDM-600 offers this uncoded mode for three modulation types - BPSK, QPSK, and OQPSK. However, the user should be aware of some of the implications of using this approach.

PSK demodulators have two inherent undesirable features. The first of these is known as 'phase ambiguity', and is due to the fact the demodulator does not have any absolute phase reference, and in the process of carrier recovery, the demodulator can lock up in any of K phase states, where K = 2 for BPSK, K = 4 for QPSK. Without the ability to resolve these ambiguous states there would be a 1-in-2 chance that the data at the output of the demodulator would be wrong, in the case of BPSK. For QPSK, the probability would be 3 in 4.

The problem is solved in the case of BPSK by differentially encoding the data prior to transmission, and then performing the inverse decoding process. This is a very simple process, but has the disadvantage that it doubles the receive BER. For every bit error the demodulator produces, the differential decoder produces two.

The problem for QPSK is more complex, as there are 4 possible lock states, leading to 4 ambiguities. When FEC is employed, the lock state of the FEC decoder can be used to resolve two of the four ambiguities, and the remaining two can be resolved using serial differential encoding/decoding. However, when no FEC is being used, an entirely different scheme must be used. Therefore, in QPSK, a parallel differential encoding/decoding technique is used, but has the disadvantage that it again doubles the receive BER.

OQPSK is a different situation again, where the ambiguities result not only from not having an absolute phase reference, but also not knowing which of the two parallel paths in the demod, I or Q, contains the half-symbol delay. Another type of differential encoding is used, but yet again the error rate is doubled, compared to ideal.

**NOTE:** Whenever uncoded operation is selected, the modem offers the choice between enabling and disabling the differential encoder/decoder appropriate for the modulation type.

The second problem inherent in PSK demodulators is that of ‘data false locking’. In order to accomplish the task of carrier recovery, the demodulator must use a non-linear process. A second-order non-linearity is used for BPSK, and a fourth-order non-linearity is used for QPSK. When data at a certain symbol rate is used to modulate the carrier, the demodulator can lock at incorrect frequencies, spaced at intervals of one-quarter of the symbol rate away from the carrier. Fortunately, when FEC decoding is used, the decoder synchronization state can be used to verify the correct lock point has been achieved, and to reject the false locks.

However, if uncoded operation is used, there is no way to recognize a data false lock. The demodulator will indicate that it is correctly locked, but the data out will not be correct. In Firmware Version 1.3.1 or higher, a new signal processing algorithm avoids this problem.



**When using Firmware Versions prior to 1.3.1, Comtech EF Data strongly cautions users when using uncoded operation. If the acquisition sweep width exceeds one quarter of the symbol rate, there is a very high probability that the demodulator will false lock. For Firmware version 1.3.1 or higher, the problem has been eliminated.**

**Example 1: A Firmware Version prior to 1.3.1 is being used, and the user selects 64 kbps QPSK, uncoded. The symbol rate will be half of this rate, or 32 ksymbols/second. One quarter of this equals 8 kHz. Therefore, the absolute maximum acquisition sweep range which should be considered is  $\pm 8$  kHz. If there is any frequency uncertainty on the incoming carrier, this should be subtracted from the sweep width. The problem becomes progressively better with increasing symbol rate.**

**Example 2: A Firmware Version of 1.3.1, or higher is used. There is no limitation on acquisition sweep width.**

Comtech EF Data cannot be held responsible for incorrect operation if the user does not adhere to these guidelines when using uncoded operation.



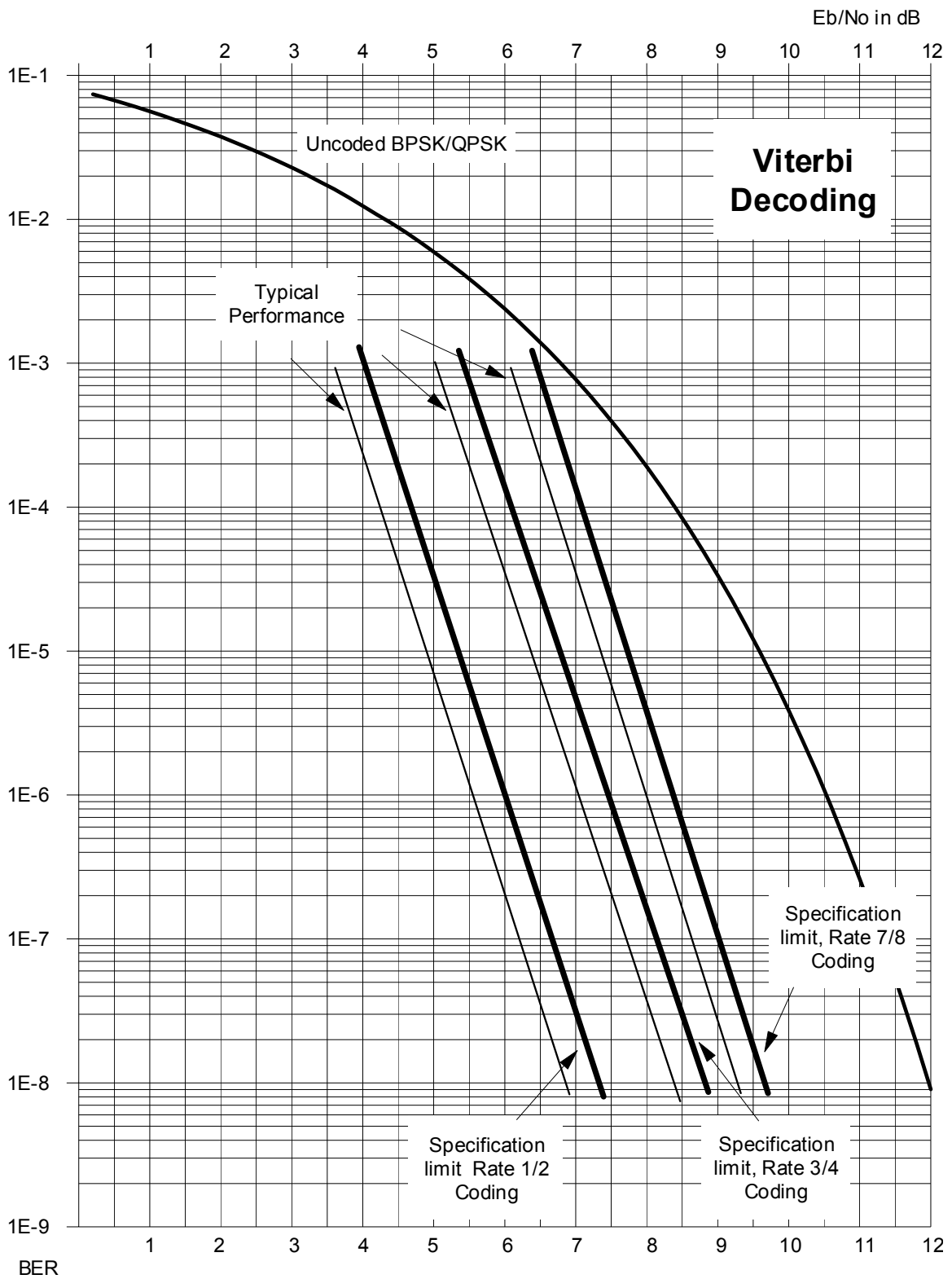

Figure 7-1. Viterbi Decoding

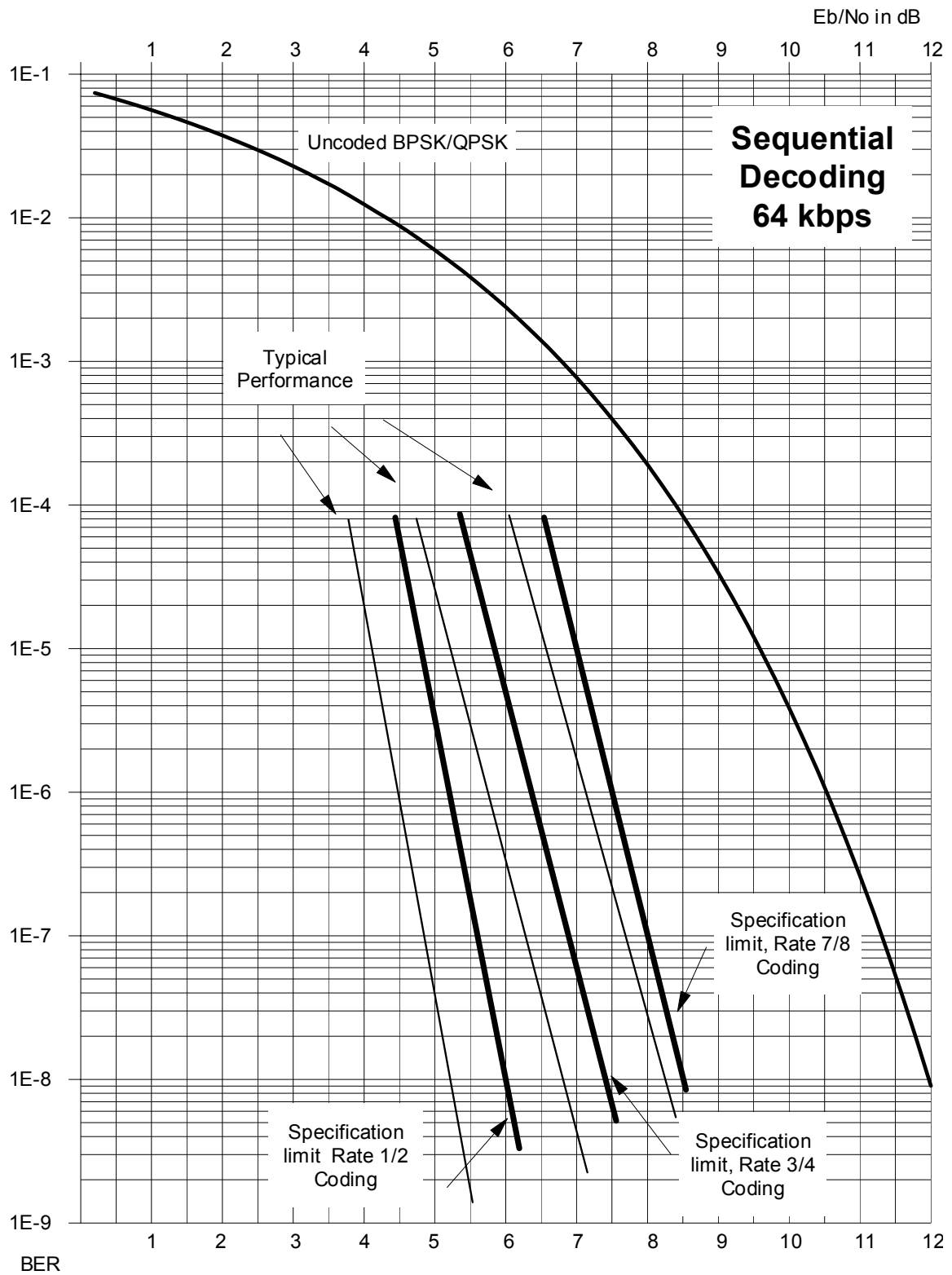

Figure 7-2. Sequential Decoding 64 kbps

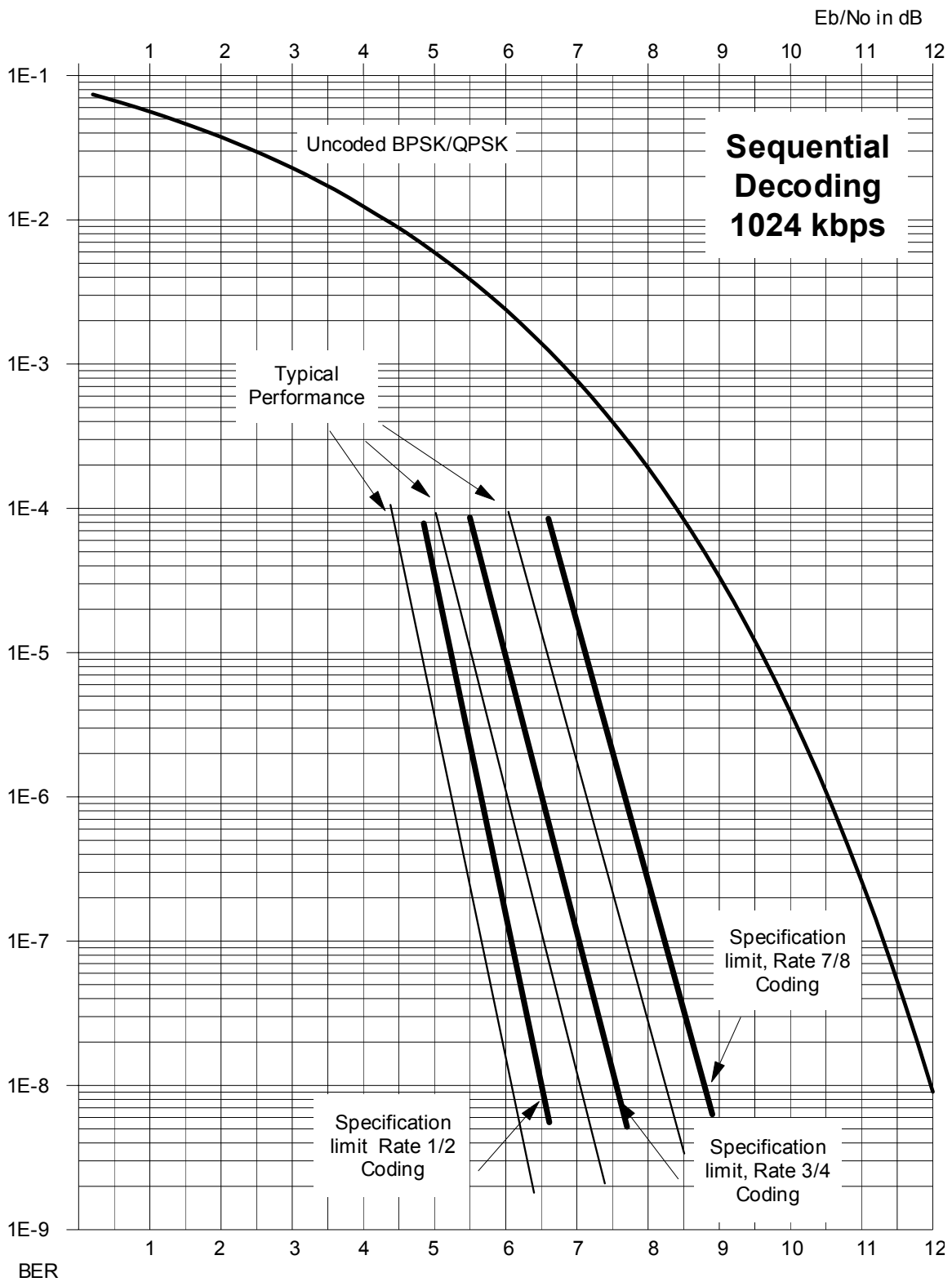
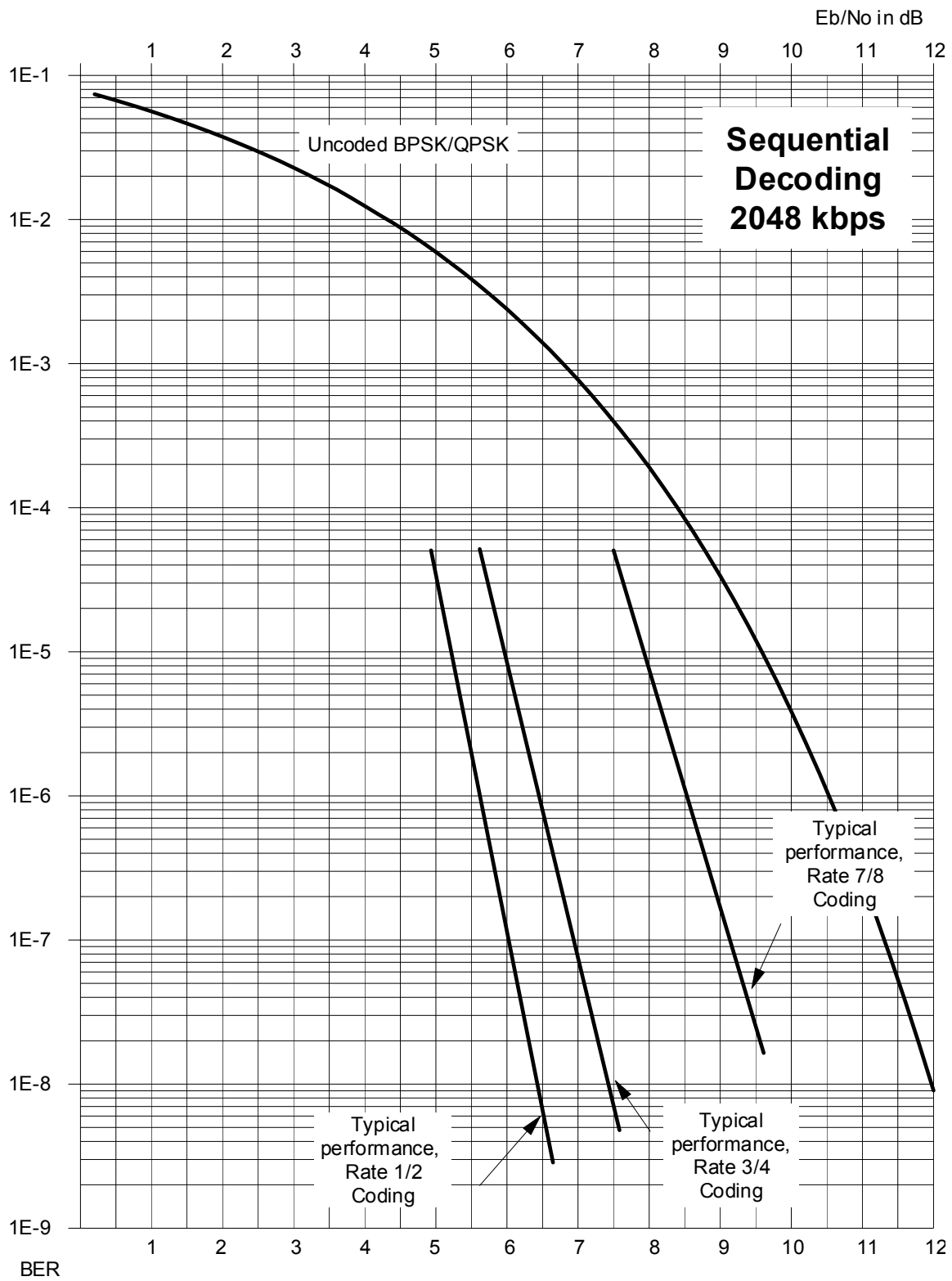

Figure 7-3. Sequential Decoding 1024 kbps



**Figure 7-4. Sequential Decoding 2048 kbps**

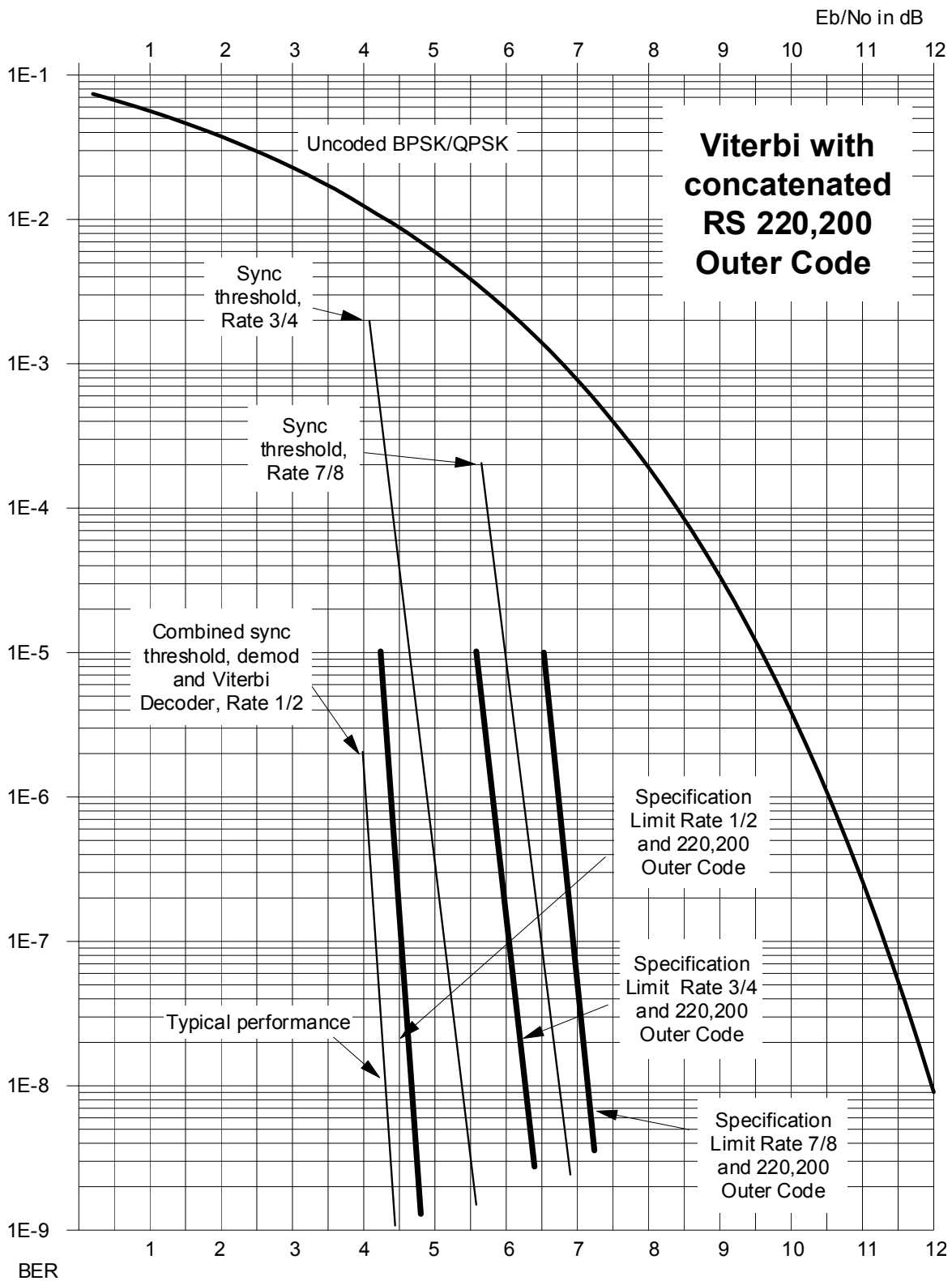

Figure 7-5. Viterbi with concatenated R-S Outer Code

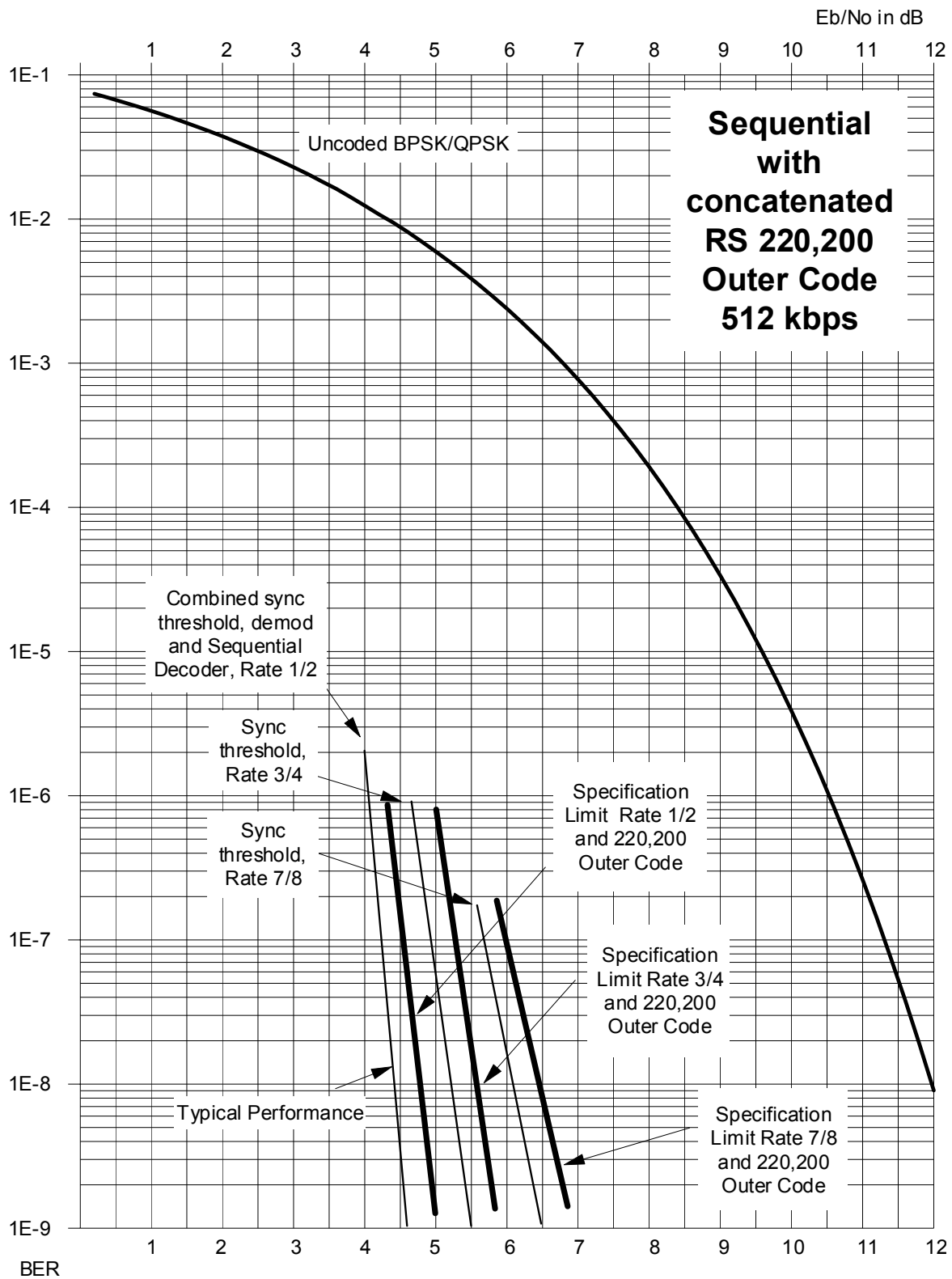
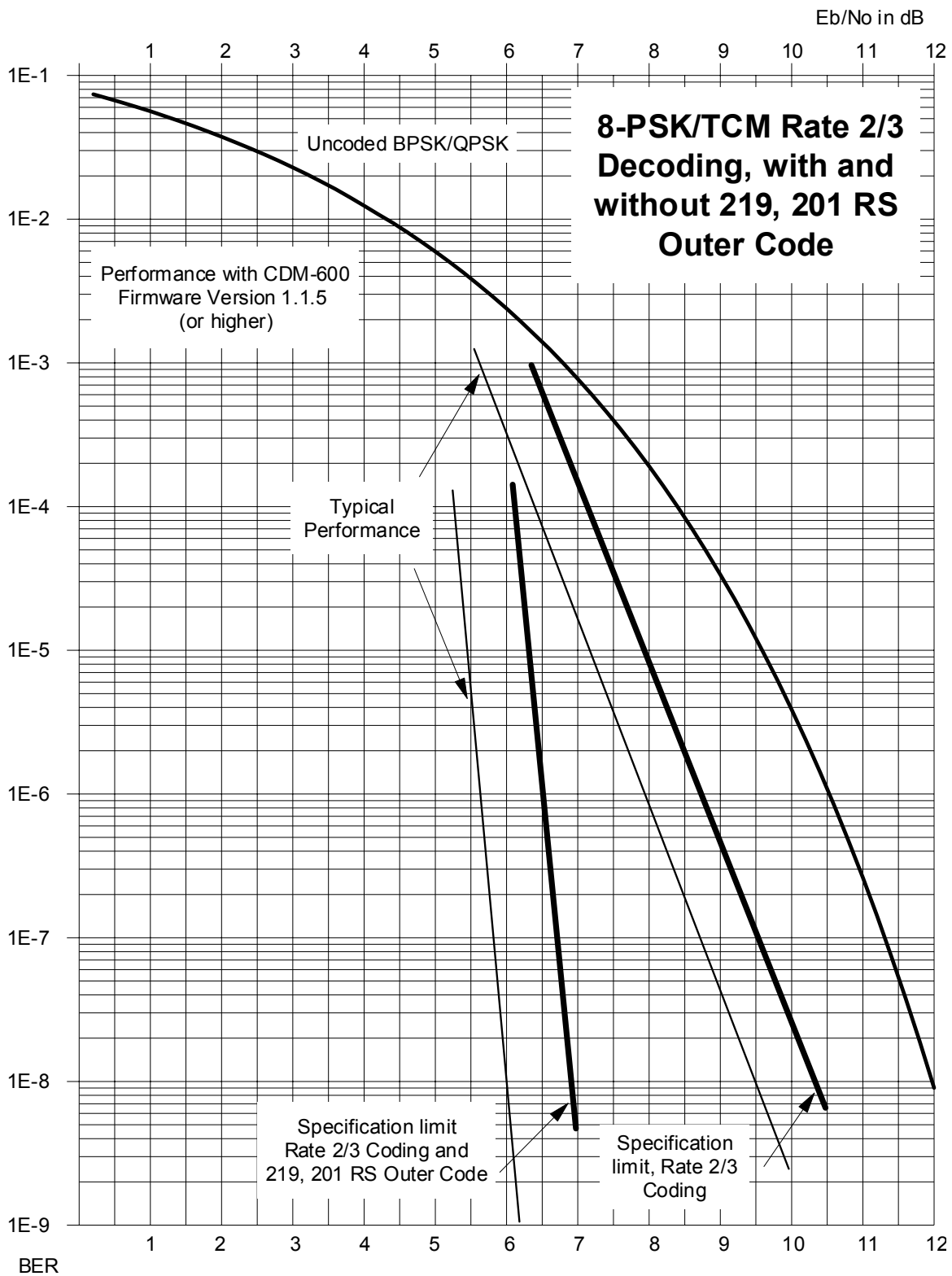
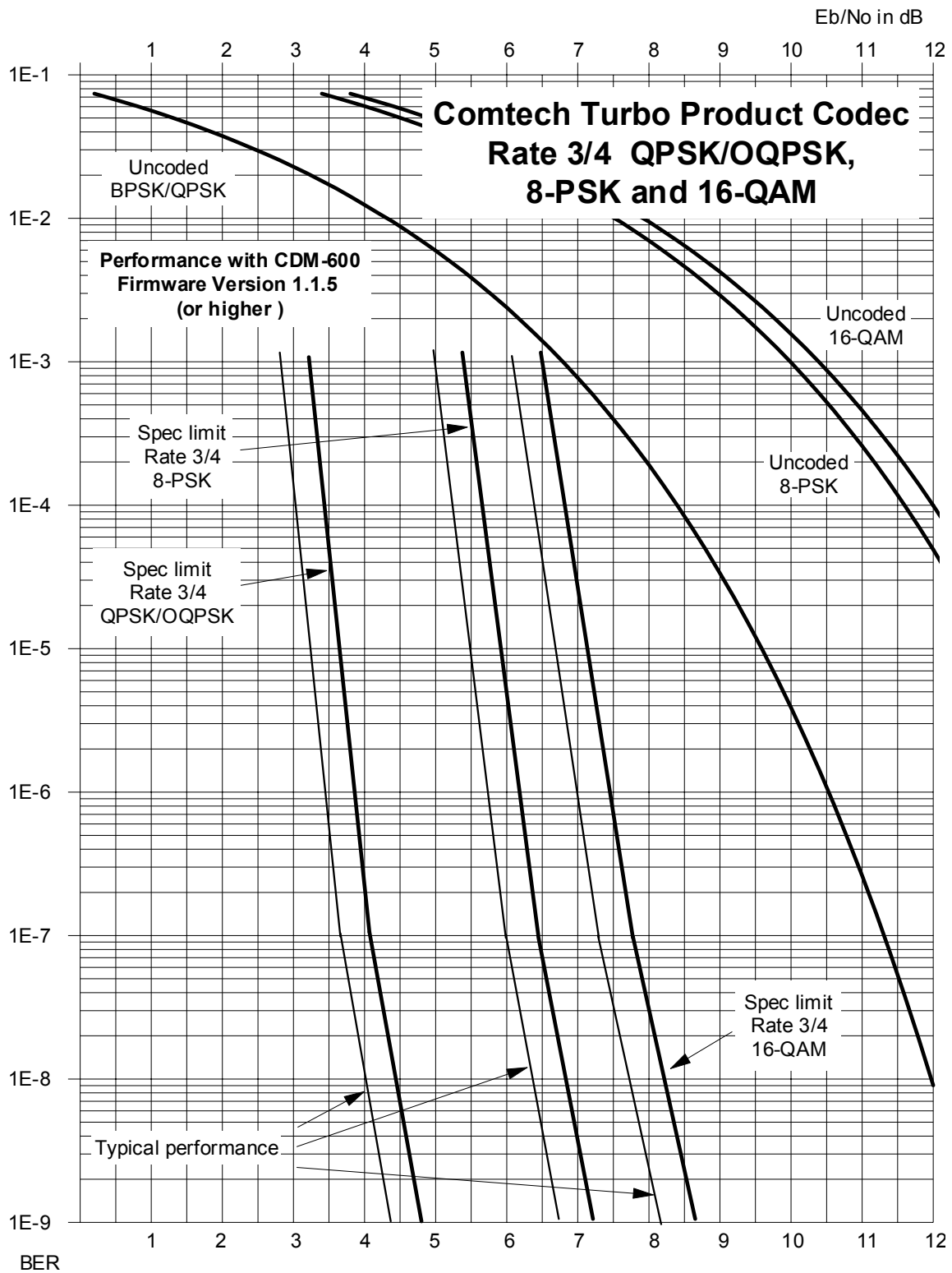

Figure 7-6. Sequential with concatenated R-S Outer Code

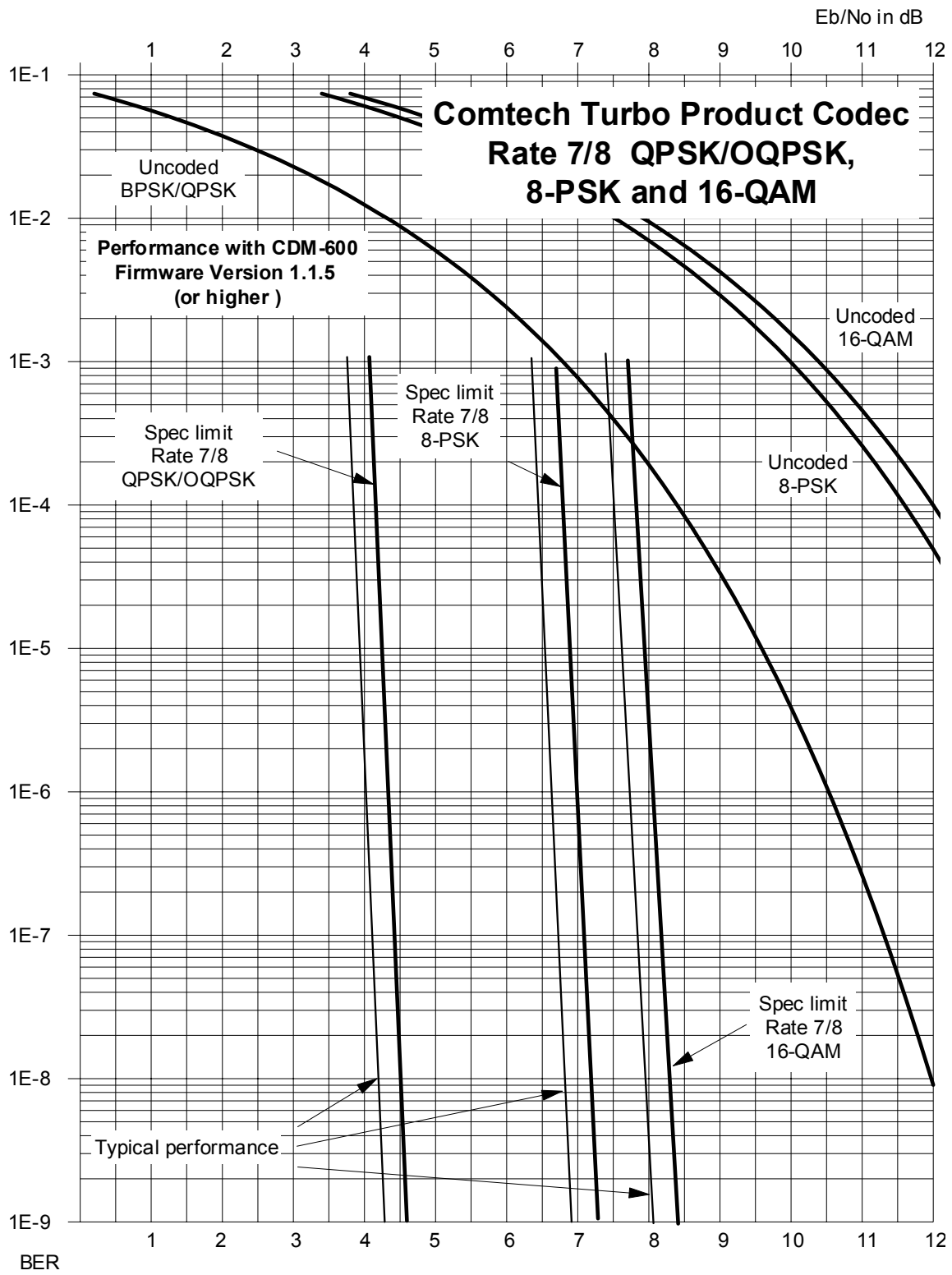

**Figure 7-7. 8-PSK/TCM Rate 2/3 with and without concatenated RS Outer Code**



**Figure 7-8. Comtech EF Data Turbo Product Codec  
Rate 3/4 QPSK/OQPSK, 8-PSK and 16-QAM**





**Figure 7-9. Comtech EF Data Turbo Product Codec  
Rate 7/8 QPSK/OQPSK, 8-PSK and 16-QAM**

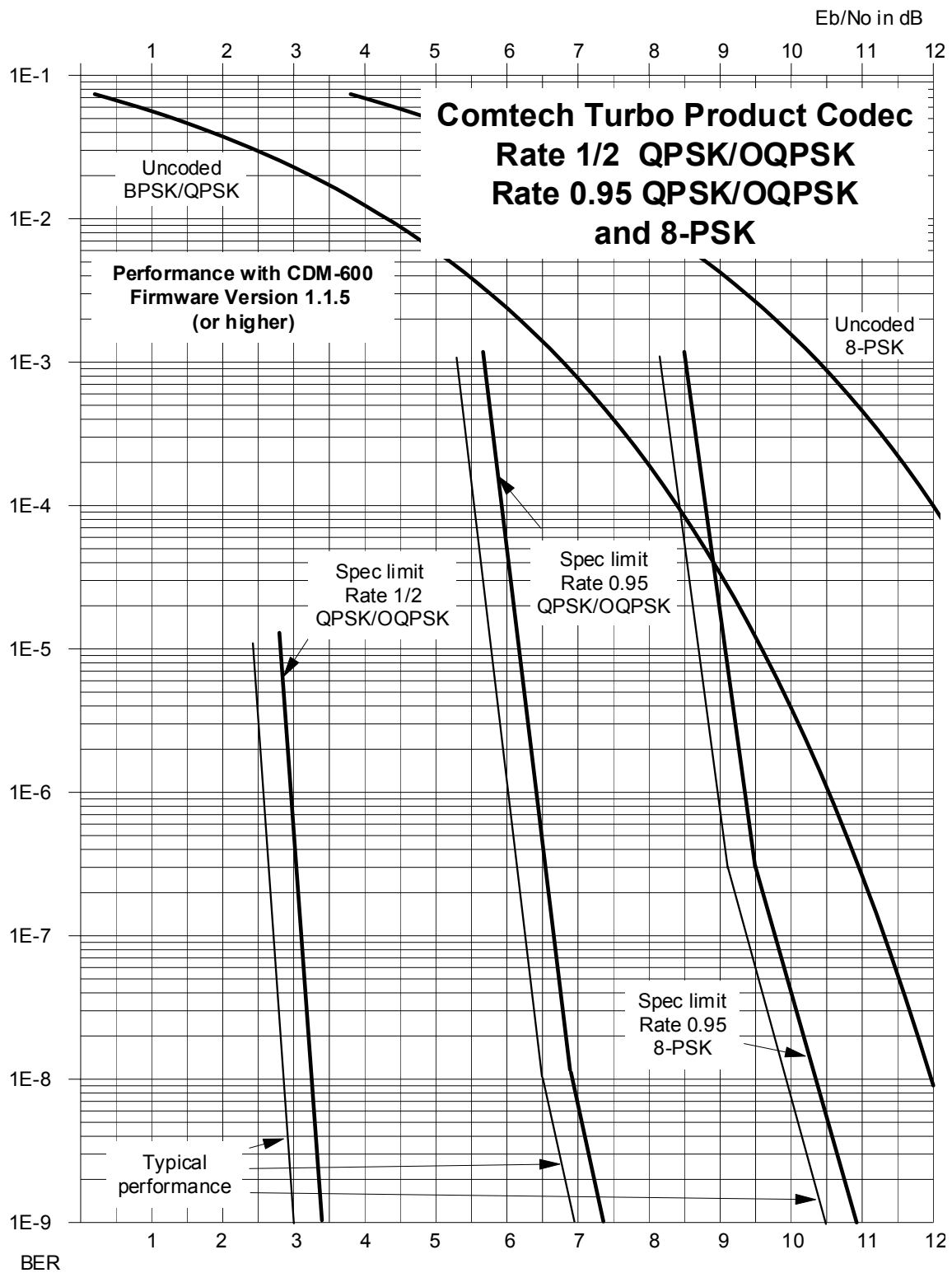

Figure 7-10. Rate 1/2 QPSK, Rate 0.95 QPSK and Rate 0.95 8-PSK

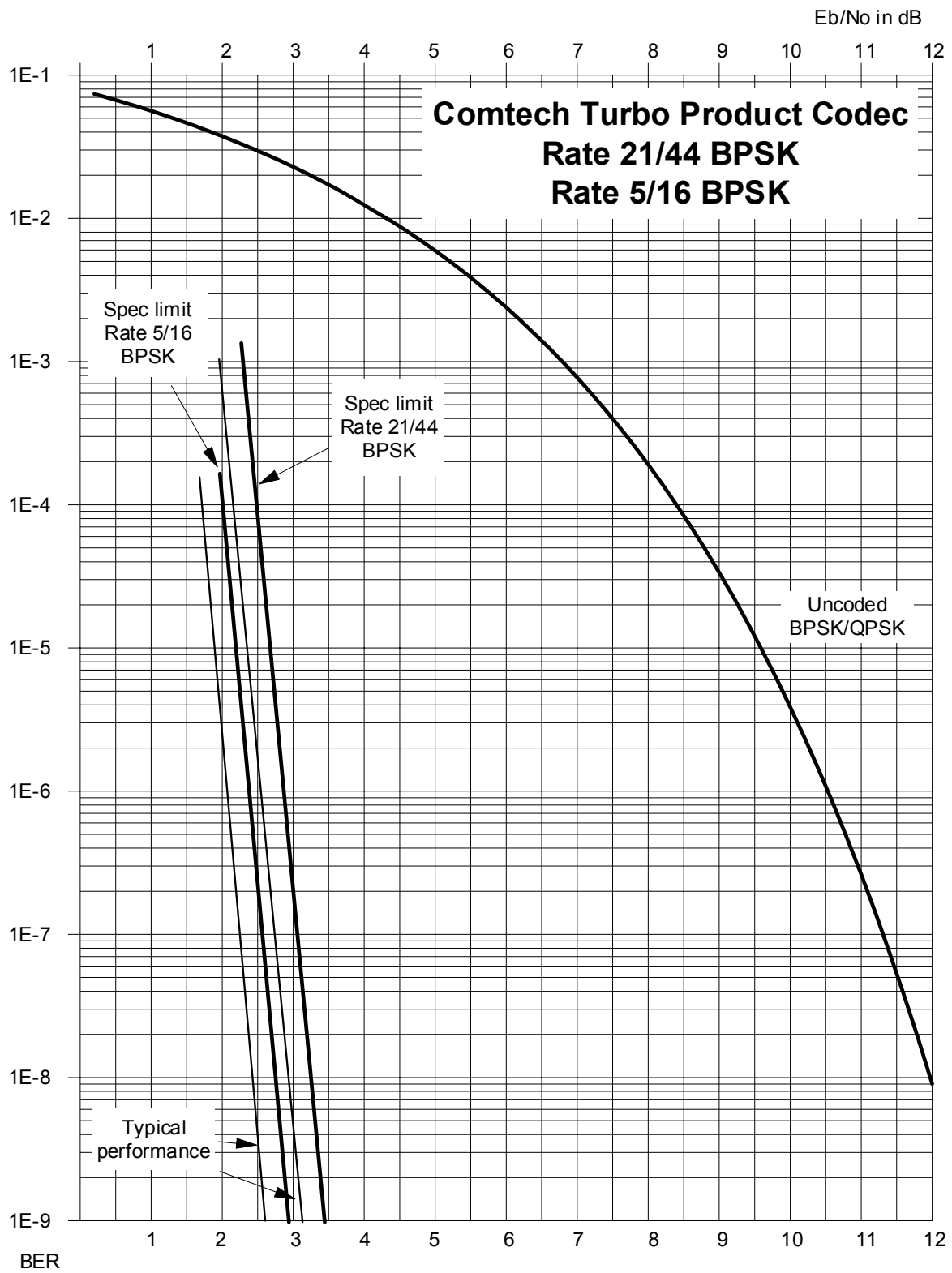

Figure 7-11. Rate 21/44 BPSK and Rate 5/16 BPSK Turbo

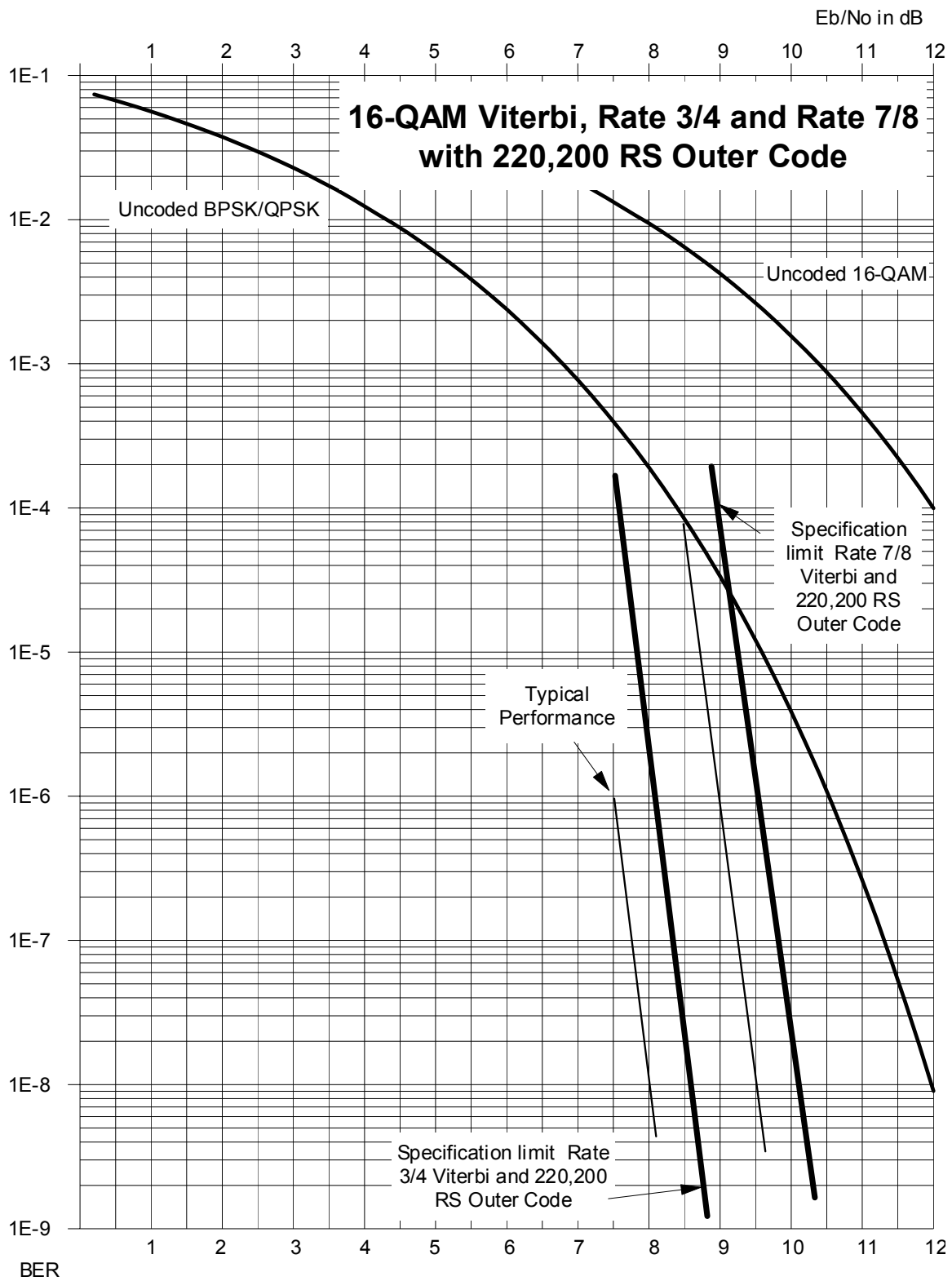

Figure 7-12. 16-QAM Viterbi, Rate 3/4 and Rate 7/8 with 220,200 RS Outer Code

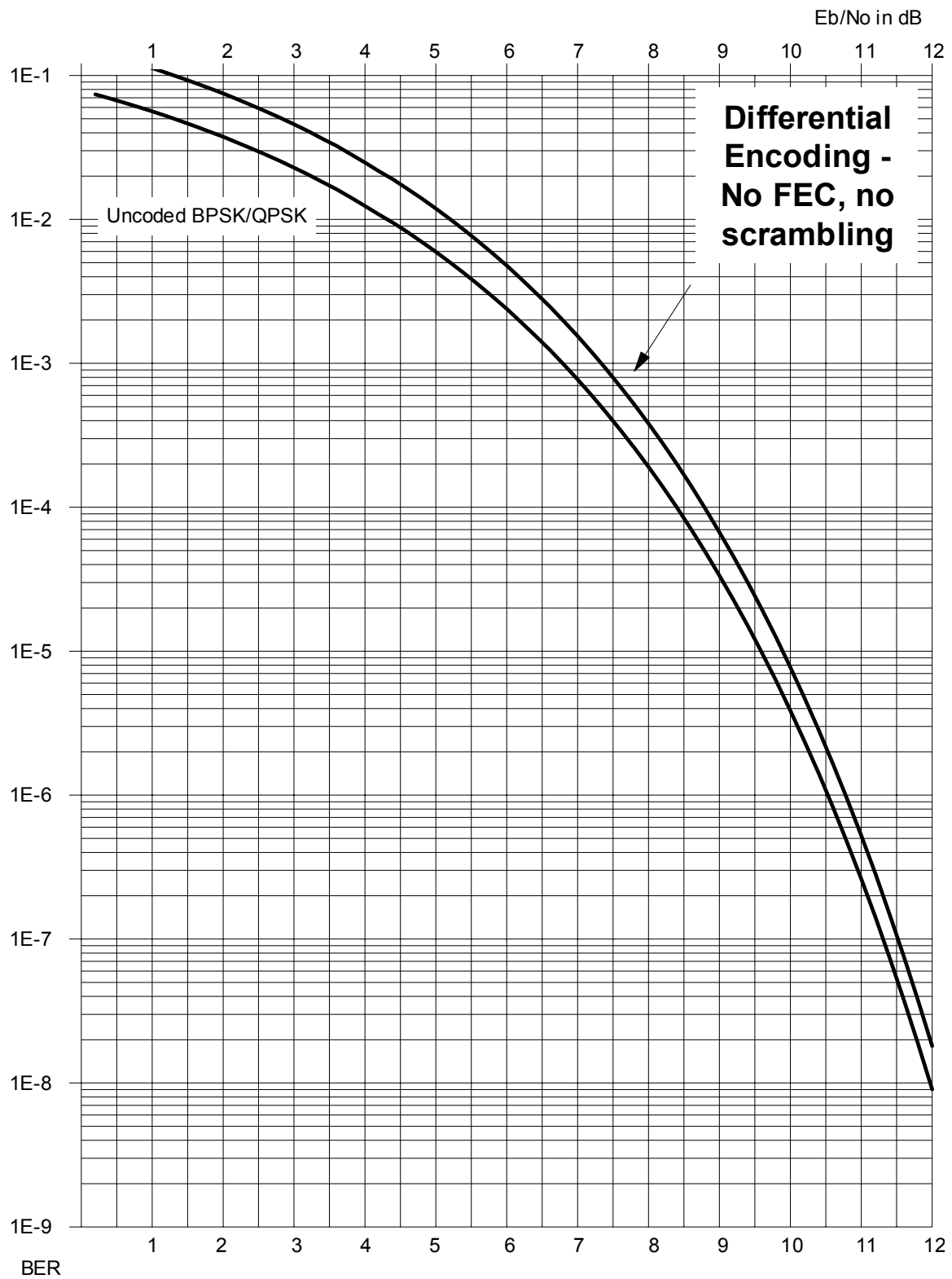

Figure 7-13. Differential Encoding - No FEC, No Scrambling

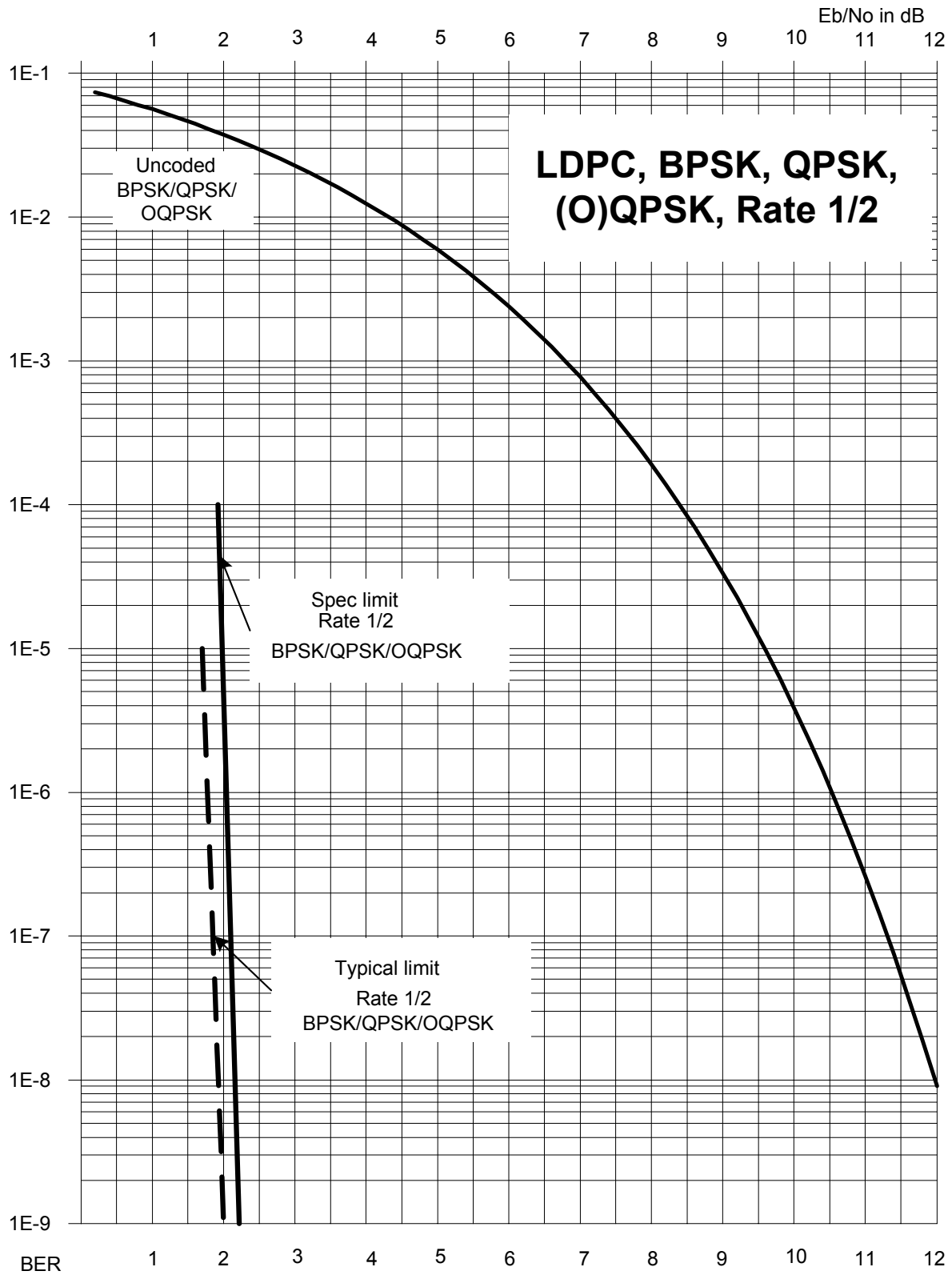

Figure 7-14. LDPC, Rate 1/2, BPSK, (O)QPSK

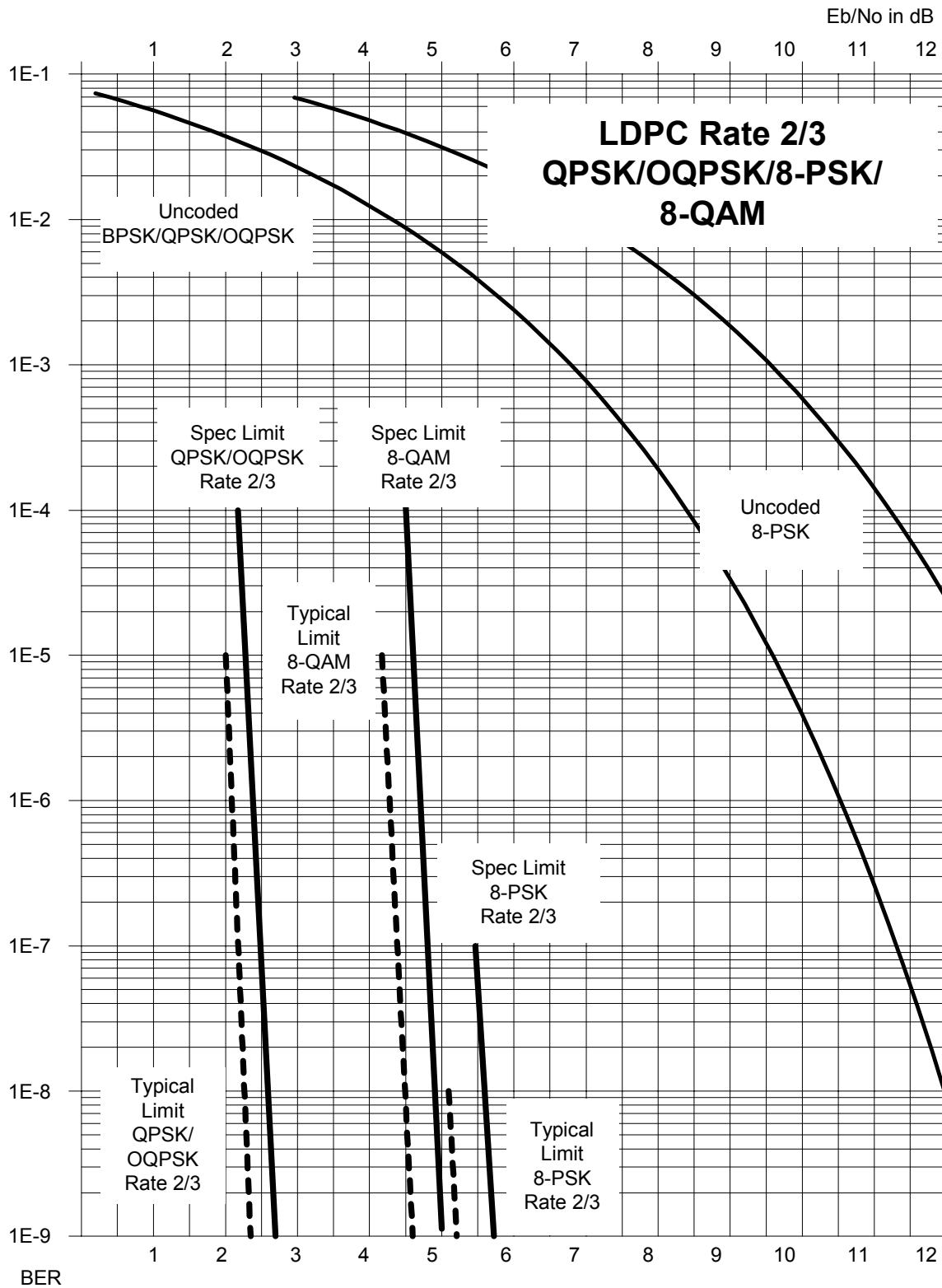

Figure 7-15. LDPC, Rate 2/3, (O)QPSK/8-PSK/8-QAM

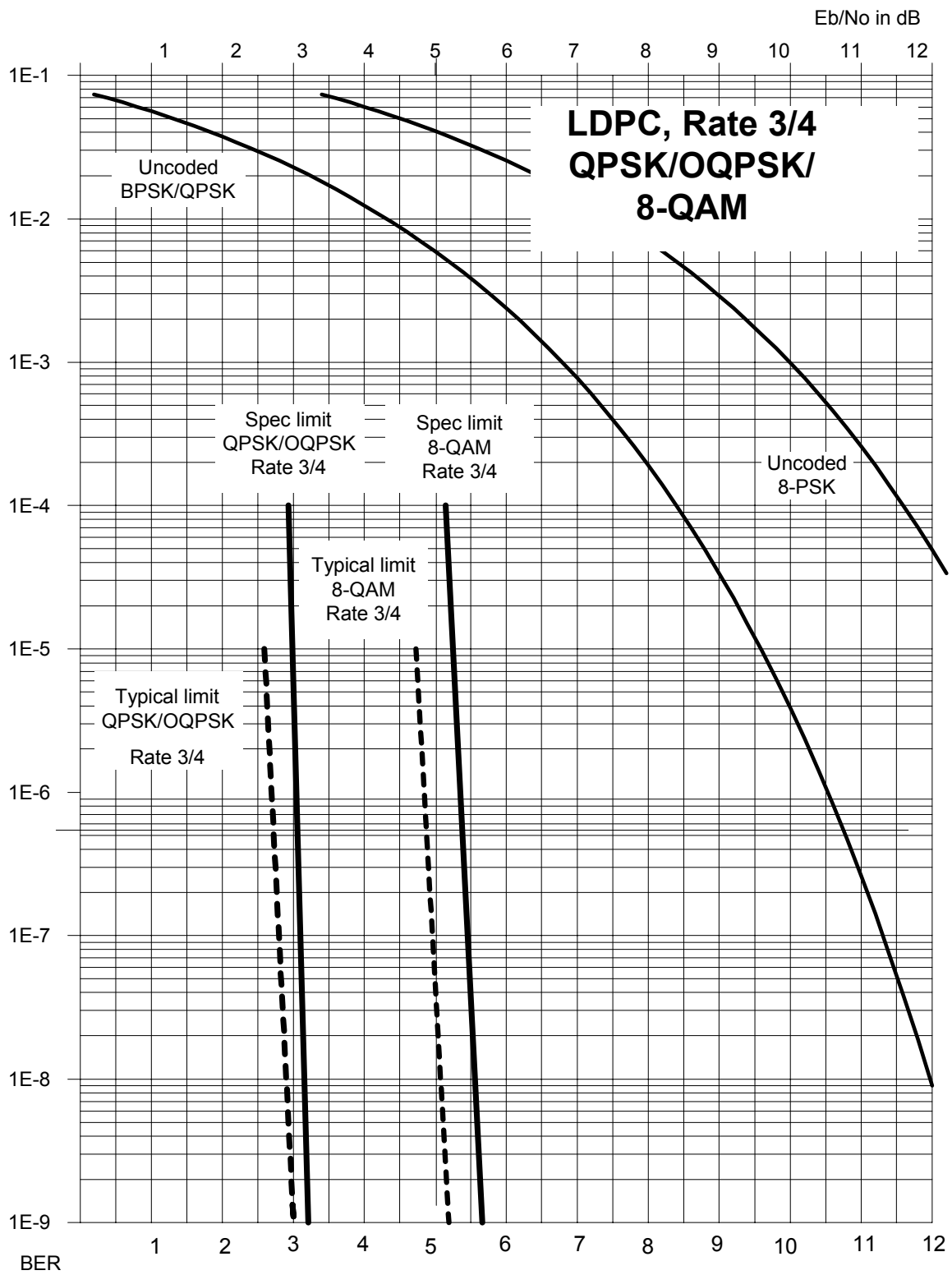
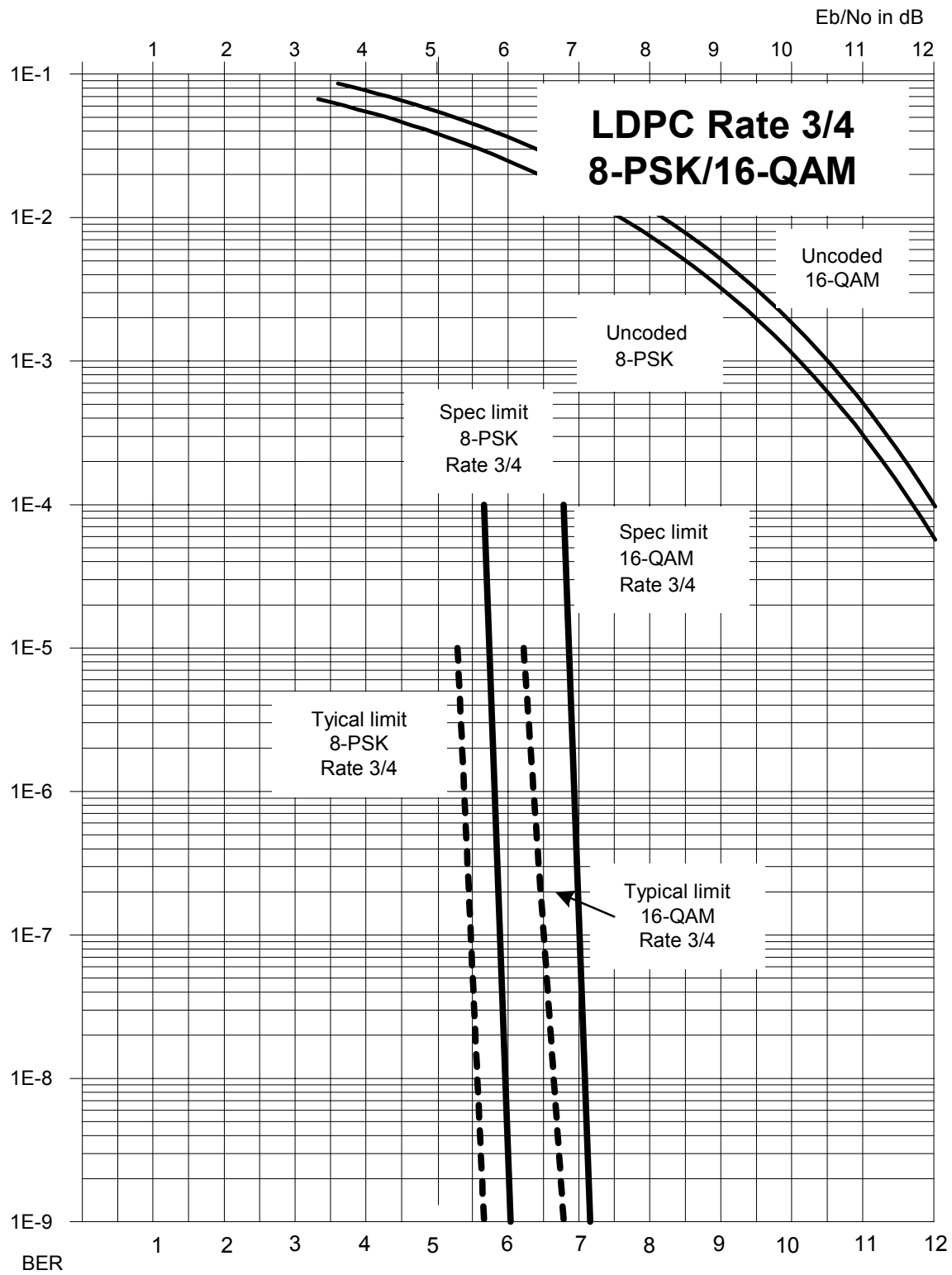

Figure 7-16. LDPC, Rate 3/4, (O)QPSK/8-QAM





**Figure 7-17. LDPC, Rate 3/4, 8-PSK / 8-QAM**

This page is intentionally blank

# Chapter 8. OFFSET QPSK OPERATION

Offset QPSK modulation is a variation of normal QPSK, which is offered in the CDM-600. Normal, bandlimited, QPSK produces an RF signal envelope that necessarily goes through a point of zero amplitude when the modulator transitions through non-adjacent phase states. This is not considered to be a problem in most communication systems, as long as the entire signal processing chain is linear.

However, when bandlimited QPSK is passed through a non-linearity (for instance, a saturated power amplifier), there is a tendency for the carefully-filtered spectrum to degrade. This phenomenon is termed 'spectral re-growth', and at the extreme (hard limiting) the original, unfiltered  $\sin(x)/x$  spectrum would result. In most systems, this would cause an unacceptable level of interference to adjacent carriers, and would cause degradation of the BER performance of the corresponding demodulator.

To overcome the problem of the envelope collapsing to a point of zero amplitude, Offset QPSK places a delay between I and Q channels of exactly  $1/2$  symbol. Now the modulator cannot transition through zero when faced with non-adjacent phase states. The result is that there is far less variation in the envelope of the signal, and non-linearities do not cause the same level of degradation.

The demodulator must re-align the I and Q symbol streams before the process of carrier recovery can take place. For various reasons this makes the process of acquisition more difficult.

The two consequences of this are:

1. Acquisition may be longer, especially at low data rates.
2. The acquisition threshold is higher than for normal QPSK, although the demodulator will maintain lock down to its normal levels. For Firmware Versions prior to 1.3.1, the acquisition thresholds are as follows:

7.0 dB Eb/No for Rate 1/2

5.2 dB Eb/No for Rate 3/4

4.8 dB Eb/No for Rate 7/8

4.0 dB Eb/No for Uncoded operation (No FEC)

Firmware Versions of 1.3.1, or higher, have improved these figures by approximately 2-3 dB.

# Chapter 9. OPEN NETWORK OPERATIONS

---

## 9.1 Introduction

This section summarizes the functionality and specifications of the various Open Network operating modes (IDR, IBS and Drop and Insert).

---

## 9.2 IBS

Primary Data Rates Supported	
G.703	1544, 2048, 6312 and 8448 kbps SD, RD
EIA-422, V.35, LVDS	N x 64 kbps SD, RD (up to 8448 kbps)
ADPCM Audio (2 Channels)	64 kbps only, full duplex

Engineering Service Channel	
Earth Station-to-Earth Station Channel	EIA-232 data synchronous at 1/480 of the primary data EIA-232 data asynchronous at 1/2000 of the primary data

High Rate Engineering Service Channel	
ESC Data Interface Type	Async – configurable async character format, EIA-232 at up to 1/20 <sup>th</sup> of primary data rate
ESC Data Rate	Example: 2400 baud at 64 kbps

Faults and Alarms	
Satellite Backward Alarm	1 (per IESS-309)
Receive BWA Output	Enabled onto terrestrial secondary alarm

### 9.2.1 IBS Clock/data recovery and De-jitter

Performs clock and data recovery on the G.703 format. Clock de-jitter and data encoding/decoding is done as with the IDR configuration.

### 9.2.2 IBS Framing

Multiplexes/demultiplexes the primary data in compliance with the standard IESS-309 overhead ratio of 1/15 (4 overhead bytes per 60 data bytes) and provides the rate exchanged transmit clock to the modulator portion of the base modem.

### 9.2.3 IBS Engineering Service Channel

Bi-directional processing of the components of the ESC channel, including the ASYNC or SYNC EIA-232 data channel, and fault/alarm indications.

For units with FW version 1.3.1 or greater a second high-rate ESC channel, at up to 1/20<sup>th</sup> of the primary data rate, is available, using async EIA-232 format.

### 9.2.4 IBS Scrambling

Provides the synchronous scrambling/descrambling of the satellite-framed data specified in IESS-309. Base modem scrambling/descrambling is disabled in this mode.

---

## 9.3 Drop and Insert

Primary Data Rates Supported	
G.703, EIA-422, V.35 and Serial LVDS	1544 kbps SD, RD, DDO, IDI 2048 kbps SD, RD, DDO, IDI
Satellite Data Rates Supported (all have 16/15 overhead)	N x 64 kbps N = 1, 2, 3, 4, 5, 6, 8, 10, 12, 15, 16, 20, or 24 (T1) N = 1, 2, 3, 4, 5, 6, 8, 10, 12, 15, 16, 20, 24, or 30 (E1-CCS) N = 1, 2, 4, 6, 8, 12, 16, 24, 30 (E1-CAS)
Terrestrial Framing Supported	G.732/G.733, G.704
Satellite Overhead Rate	16/15 of data rate per IESS-308 Rev. 6 and IESS-309 Rev. 3, or higher
Timeslot Selection Range	1 to 24 (all T1 modes) 1 to 30 (E1-CAS and E1-CCS) Arbitrary order, non-contiguous available
Plesiochronous Buffer Sizes	Selectable size of 64 to 262,144 bits, in 16-bit steps (with added limitations for G.704 frame boundaries)

Buffer Clock Reference	Derived from Insert Data In (Insert Clock) External, RX (satellite) or TX (Terrestrial)
<b>Asynchronous Engineering Service Channel</b>	
ESC Data Interface Type	EIA-232, Asynchronous
ESC Data Rate	1/2000 of primary data rate
ESC Data Circuits Supported	SD, RD, DSR

<b>Synchronous Engineering Service Channel</b>	
ESC Data Interface Type	EIA-232, synchronous to primary data
ESC Data Rate	1/480 of primary data rate
ESC Data Circuits Supported	SD, ST, RD, RT, DSR

<b>Faults and Alarms</b>	
Satellite Backward Alarm	1 (per IESS-309)
Receive BWA Output	Enabled onto terrestrial secondary alarm

### 9.3.1 D&I Primary Data Interfaces

When configured for D&I operation, multiplexing/demultiplexing follows the IBS satellite frame structure and ESC features, but with the following changes:

- Accepts and outputs primary data through the G.703 connectors.
- The data rate must be at T1 or E1 rates only. This includes additional links for Drop Data Out and Insert Data In.
- Clock recovery, dejitter, and encoding/decoding are performed as before.

### 9.3.2 D&I Framing

The IBS satellite framing/deframing is applied only to selected time slots of the data's G.704 terrestrial structure.

## 9.4 IDR

Primary Data Rates Supported	
G.703	1544 kbps SD, RD
EIA-422 (Replaces 8K Overhead)	2048 kbps SD, RD
V.35 (Replaces 8K Overhead)	6312 kbps SD, RD
	8448 kbps SD, RD

Engineering Service Channel	
ESC Audio	2 duplex ADPCM channels
Audio Encoding	CCITT G.721
Audio Interface Type	600Ω transformer-balanced 4-wire
Audio Input Level	Nominal Input : 0dBm0 (-3dBm, 600Ω) Adjustment range: -6 to +8 dB, 2 dB steps
Audio Output Level	Adjustment range: -6 to +8 dB, 2 dB steps
Audio Filtering	Internal 300 to 3400 Hz input and output
ESC Data Interface Type	EIA-422
ESC Data Rate	8 kbps, also 64 kbps if ADPCM audio is not used
ESC Data Circuits Supported	SD, ST, RD, RT, Octet in, Octet out
Data Signal Phasing	Per EIA-449, data changes on the rising clock transition, is sampled on the falling clock edge
Octet Timing	Octet high with every 8 <sup>th</sup> bit, aligns with frame bit d8

Faults and Alarms	
Backward Alarms Supported	4 input, 4 output
Backward Alarm Inputs	1 kΩ pull up to ground, set high to activate.
Backward Alarm Outputs	Form C Relay, N/O, N/C, Com



### 9.4.1 IDR Primary Data Interfaces

When configured for IDR operation, the board performs these functions:

- Receives and performs clock and data recovery on incoming G.703 T1 and E1 pseudo-ternary data.
- Clock dejitter is performed per G.823 and G.824, and any data decoding (AMI, B8Z5, or HDB3) required per G.703 is also accomplished.  
IDR Framing

Multiplexes in compliance with the standard IESS-308 96 kbps ESC overhead onto the data and provides both the data and rate exchanged clock to the modulator portion of the base modem.

Performs the corresponding demultiplexing of Rx satellite data received from the demodulator portion of the modem. Resulting G.703 data is optionally encoded (AMI, B8ZS, or HDB3) before being output.

### 9.4.2 IDR Engineering Service Channel

Bi-directional processing of the components of the ESC channel, including the ADPCM audio channels, 8 kbps data channel, and fault indications specified by IESS-403 and IESS-308.

Option of using the ADPCM portion of the satellite overhead for a single 64 kbps ESC data channel in addition to (and with the same format as) the 8 kbps data channel.

When using G.703 format for the primary IDR data path, the P3B primary data interface (25-pin) is used for the 8kbps overhead channel. If EIA-422 or V.35 is used, P3B becomes the primary interface and the 8kbps channel is unavailable.

This page is intentionally blank

# Chapter 10. CLOCK MODES AND DROP AND INSERT (D&I)

When dealing with satellite modems, the subject of clocking can be a complex issue. This section describes the various clocking options that are available with the CDM-600. There are two fundamentally different interfaces provided by the modem:

- Synchronous clock and data interfaces (EIA-422, V.35, etc) that permit great flexibility concerning the source and direction of clocks. These cause the most confusion.
- G.703 interfaces, in which the clock and data are combined into a single signal (and are referred to as *self-clocking*). In their basic form these are less flexible, and hence easier to understand. However, when used with Drop and Insert operation, the subject again becomes more complex.

---

## 10.1 Transmit Clocking

There are five transmit clocking modes in the CDM-600. EIA-422/449 signal mnemonics will be used for illustration, but the description applies equally to V.35, and synchronous EIA-232.

### 10.1.1 Internal Clock

In this mode, the modem, assumed always to be the DCE, supplies the clock to the DTE. (The EIA-422/449 name for this signal is Send Timing, or ST.) The DTE then clocks from this source, and gives the modem transmit data (Send Data, or SD), synchronous with this clock. It is optional whether the DTE also returns the clock (Terminal Timing, or TT) - the modem can accept it if it is present, but uses ST if it is not. At rates above 2 Mbps, Comtech EF Data highly recommends that the user returns TT to ensure the correct clock/data relationship.

**G.703:** The internal clock mode does not apply – the clock is always recovered from the incoming signal, and the modem locks its modulator clocks to this.

### 10.1.2 Tx Terrestrial

In this mode, the modem expects to see the DTE provide the clock, so that it can phase-lock its internal circuits. In this case, the modem does not provide any signal on ST, but instead requires a clock signal on Terminal Timing (TT), synchronous with the data. If no clock is present, an alarm will be generated and the modem will substitute its internal clock.

**G.703:** This is the ‘natural’ clock mode.

### 10.1.3 Rx Loop-Timed, RX=TX

In certain circumstances, a terminal at the distant-end of a satellite link may be required to provide a clock to the DTE equipment which is locked to the receive satellite signal. This is similar to Internal Clock mode, in that the modem will source Send Timing (ST) to the DTE, but now the timing is derived from the demodulator. The DTE then clocks from this source, and gives the modem transmit data (Send Data, or SD), synchronous with this clock. It is optional whether the DTE also returns the clock (Terminal Timing, or TT) - the modem can accept it, if it is present, but uses ST if it is not. If the demodulator loses lock, the modem’s internal clock will be substituted, so an accurate and stable clock is present on ST, rather than a clock that may jitter and wander in a random fashion.

**G.703:** Does not apply.

### 10.1.4 Rx Loop-Timed, RX<>TX (Asymmetric Loop Timing)

The CDM-600 incorporates circuitry which permits loop timing when the TX and RX data rates are not the same. In this case the clock frequency appearing at ST will be whatever the TX data rate is programmed to, but phase-locked to the demodulator’s receive symbol clock. In all other respects the operation is the same as for ‘standard’ loop timing.

**G.703:** Does not apply.

### 10.1.5 External Clock

The modem will accept a station clock at the rear of the modem to serve as its ST clock directly. In this case, the station clock must be equal to the transmit data rate being used.

**G.703:** Does not apply.

---

## 10.2 Receive Clocking

There are three receive clocking modes in the CDM-600, plus an additional setting used for Drop and Insert only – see later section.

### 10.2.1 Buffer Disabled (RX Satellite)

When the buffer is disabled, the receive clock (Receive Timing, or RT) is derived directly from the demodulator, and hence will be subject to plesiochronous and Doppler offsets. In certain instances, this may be acceptable. There is still a minimum buffer in use to de-jitter the effects of removing overhead framing.

G.703: Applicable.

### 10.2.2 Buffer Enabled, TX=RX (TX Terrestrial or External Clock)

In this instance, it is required that buffer be enabled, so that the clock and data appearing on Receive Timing and Receive Data (RT and RD respectively) are synchronous with the transmit clock or the external reference input. This is a relatively simple case, as the output clock for the buffer is derived directly from either ST, TT or the external source.

G.703: Applicable.

### 10.2.3 Buffer Enabled, RX<>TX (TX Terrestrial or External Clock)

This is an uncommon case, where the receive data rate does not equal the transmit or external reference. The modem will generate a phase-locked buffer output clock which uses the selected reference, regardless of its frequency in relation to the receive data rate.

G.703: Applicable.

---

## 10.3 X.21 Notes

For X.21 operation, use the RS-422 pins, but ignore Receive Clock if the Modem is DTE, and ignore Transmit clocks if the Modem is DCE.

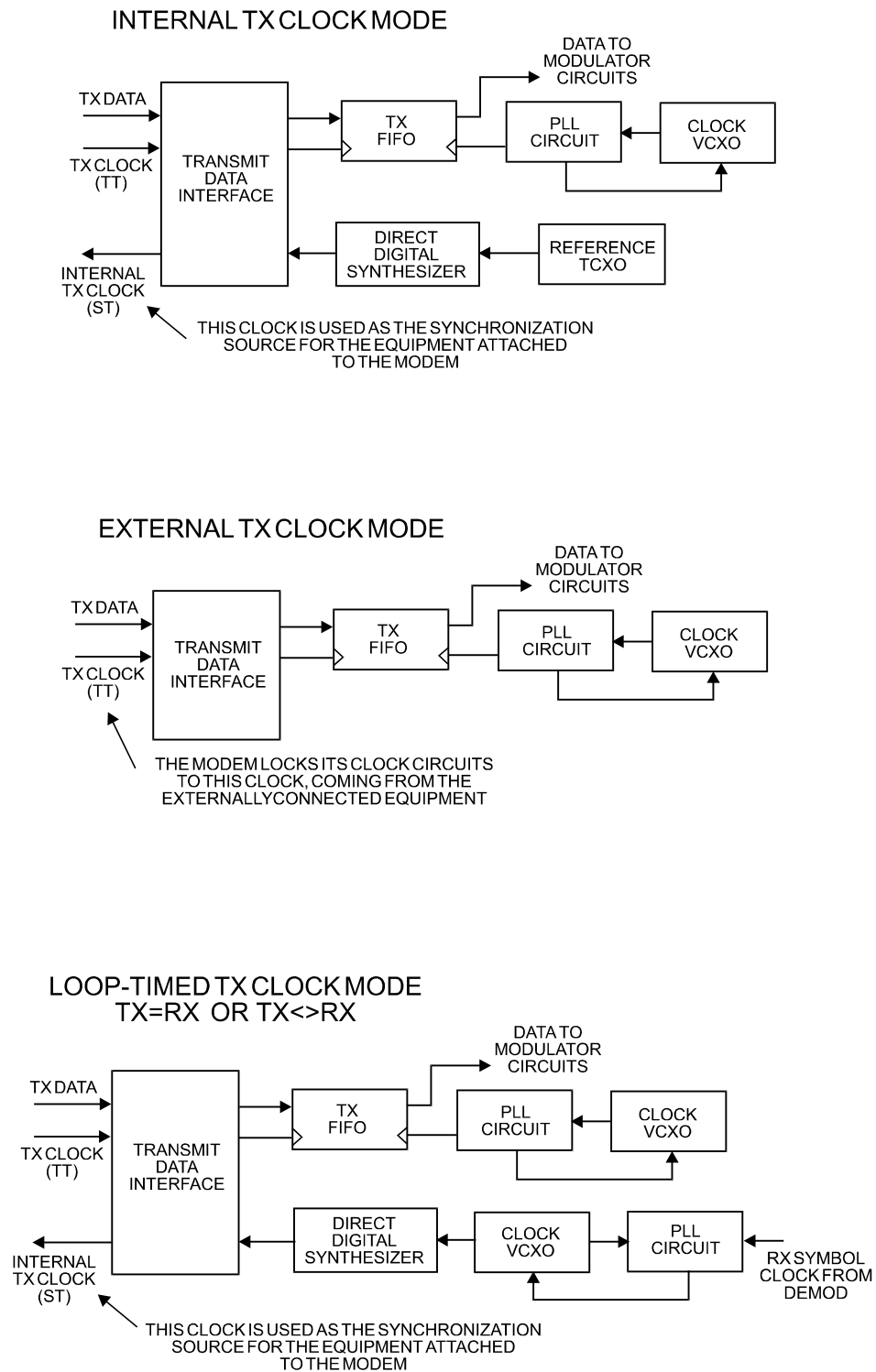

**Figure 10-1. Tx Clock Modes**

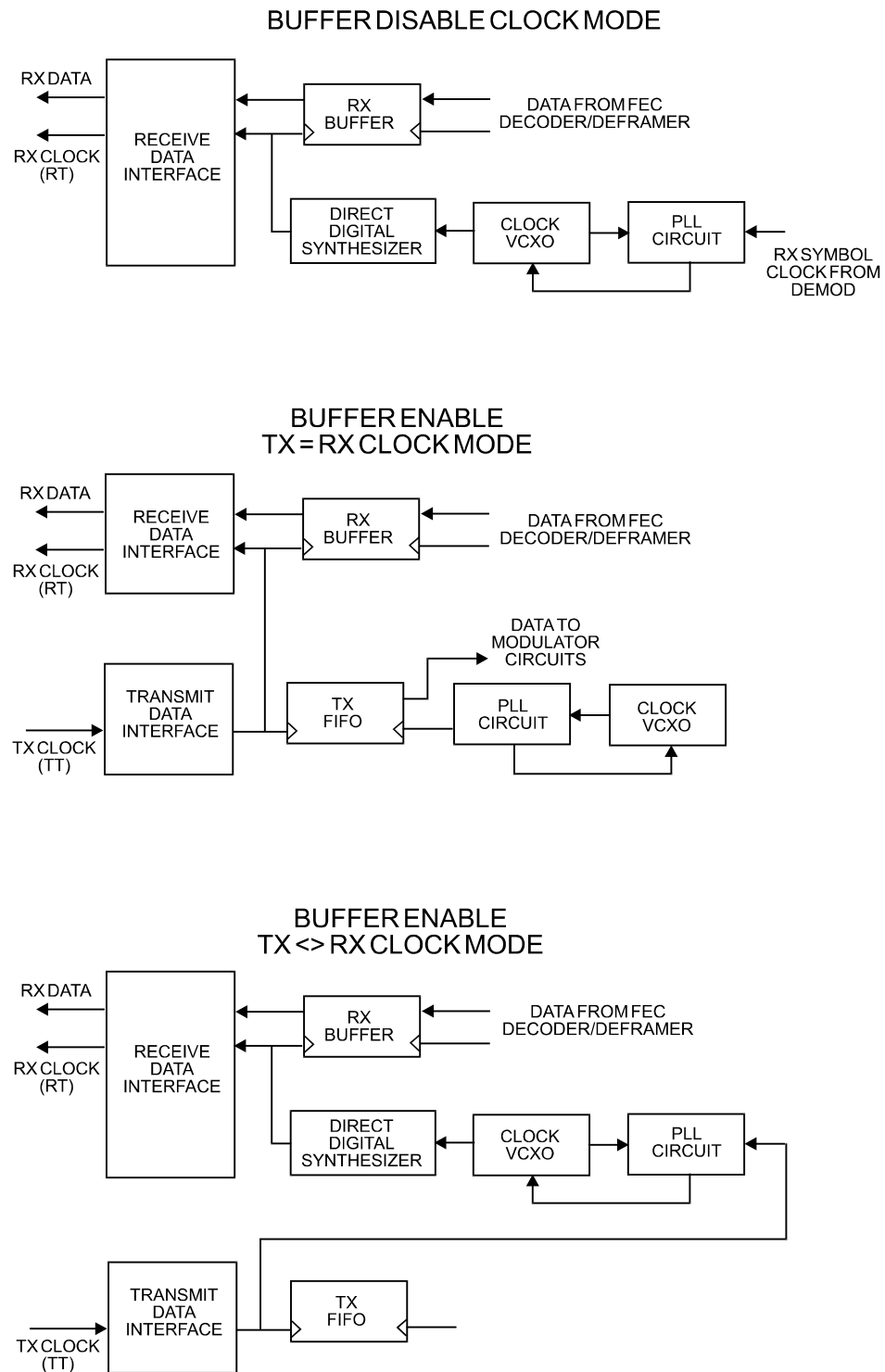

Figure 10-2. Rx Clock Modes

---

## 10.4 Drop and Insert

The Drop and Insert (D&I) multiplexer works in conjunction with the G.703 interfaces to enable the modem to transmit or receive fractional parts of a T1 or E1 data stream.

The D&I option provides fully compliant baseband processing in accordance with Intelsat IESS-309 for the terrestrial information rate of 2048 kbps (E1) and 1544 kbps (T1), using G.703 interfaces. The data rate sent over the satellite link is  $n \times 64$  kbps. See the Frame Formats diagram for the permissible values of  $n$ . The modem provides the interface to transmission level framing compliant to IESS-309 data type 2.

### Notes:

1. For Hardware Version 2.0 or higher, Firmware Version 1.3.1 or higher, D&I operation is possible through the 25-pin data port in either RS-422 or V.35 format. If used, the DDO/IDI 'inner loop' is not available.
2. For Firmware Version 1.5.0 or higher, D&I operation can also be done using the proprietary D&I++ framing mode.



## 10.5 Frame Formats

The E1 and T1 frame formats that are supported are shown in Figure 10-3:

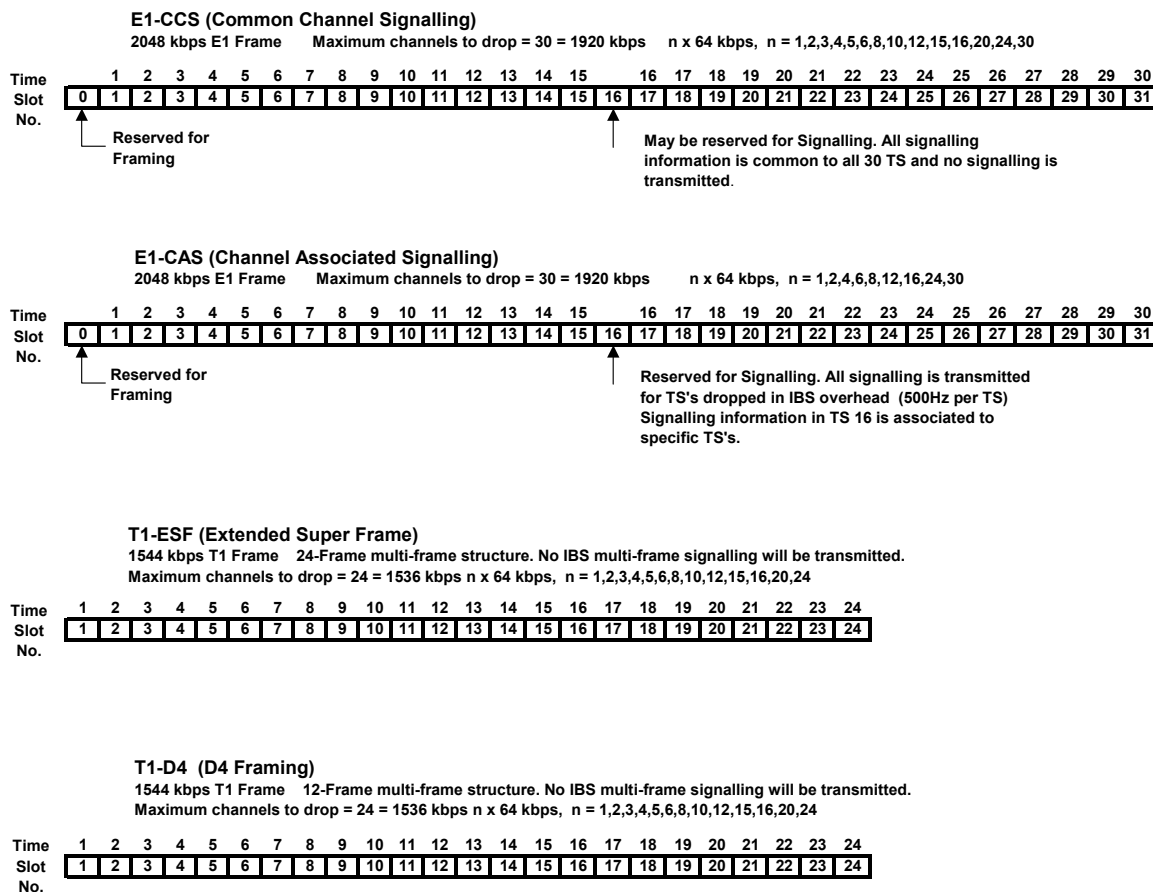

**Figure 10-3 Supported T1 and E1 Framing formats**

Note that for D&I++, the smaller overhead frame structure does not support CAS signaling, although E1 timeslot 16 may still be one of the channels transmitted.

---

## 10.6 Time Slot Selection

Selection of the transmit and receive data rates may be made in certain 64 kbps increments and may be independent of each other. The actual satellite rates for open network D&I are 16/15 of the transmit or receive data rate to include IBS overhead per IESS-309, although this is transparent to the user. For E1, the user can select any time slot (TS) from 1 to 31. Selection of TS 0 is not permitted. For T1, the user can select any time slot (TS) from 1 to 24. The user may also select “N/A” to leave a satellite channel unused.

The configuration menu allows time slots to be selected for transmission or reception up to the maximum dictated by the selected transmit or receive data rate, and may be selected in arbitrary order. As an example, if the data rate is set to 256 kbps, the maximum number of time slots that can be dropped or inserted is 4 (being 4 x 64 kbps).

Note that for 1920 kbps data rate the timeslots may not be manipulated. This is the ‘fixed channel’ mode where Timeslot 1 is assigned to Channel 1, and so on.

For D&I++ framing, all increments of 64 kbps are allowed up to a maximum of 24 (1536 kbps). For this mode, the satellite rate is 46/45 of the front panel data rate (2.22%).

## 10.7 Drop and Insert Clocking

The general arrangement for Drop and Insert clocking in the CDM-600 is shown below:

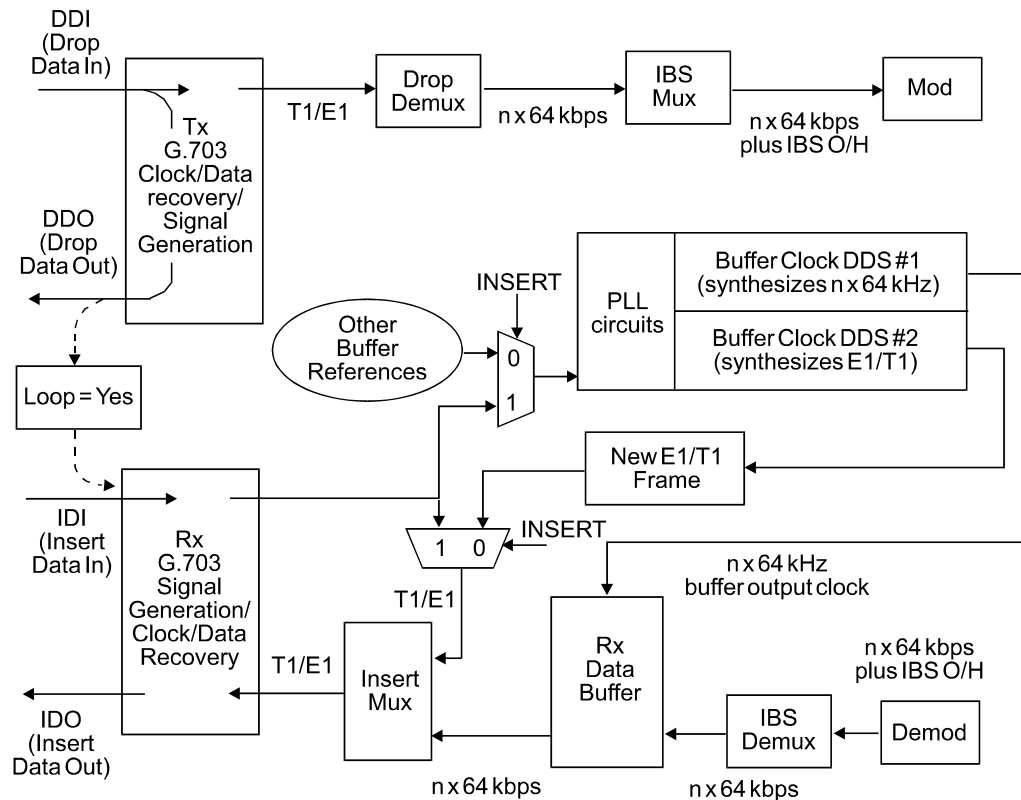

**Figure 10-4 Drop and Insert Clocking**

Note that there are two inputs and two outputs shown for Drop and Insert Operation. These are:

- Drop Data In (DDI)
- Drop Data Out (DDO)
- Insert Data In (IDI)
- Insert Data Out (IDO)

This arrangement permits the user to choose between fully independent operation of the incoming and outgoing E1/T1 signal, or to use the same T1/E1 signal for both Dropping and Inserting (looped mode). If 'Loop' has been selected under the Drop and Insert configuration menu, the Drop Data Out (DDO) signal is automatically looped internally, to become the Insert Data In (IDI).

In this mode, timeslots are dropped from an incoming E1/T1 signal for transmission over the satellite, and the *same* E1/T1 signal has time slots re-inserted into it that will overwrite data in existing timeslots.

## 10.8 Rx Buffer Clock = Insert (D&I only)

The E1 or T1 clock recovery from the IDI G.703 port serves as the Rx Buffer reference. In addition, the recovered data is the E1/T1 input to the Insert Mux. If the Rx G.703 recovery circuit detects no activity at IDI input, or cannot detect the expected frame format, Buffer Clock = Rx Satellite will be chosen as a fall-back.

If 'Insert' is *not* the selected buffer clock reference, the clock and data from the IDI port is ignored, and a new E1/T1 frame is generated. The time slots coming from the satellite are then re-inserted into the selected timeslots of this new blank frame, and output on the IDO port.

## 10.9 Single-Source Multiple Modems

Two ways to connect a single T1 or E1 stream to several modems are by looming or daisy-chaining modems. Each method is illustrated in Figure 10-5 for Looming and Figure 10-6 for daisy chain and each requires the RX Buffer Clock = Insert setting.

- Assign all timeslots to not overlap.
- Assign modems to number of TX/RX channels as required.

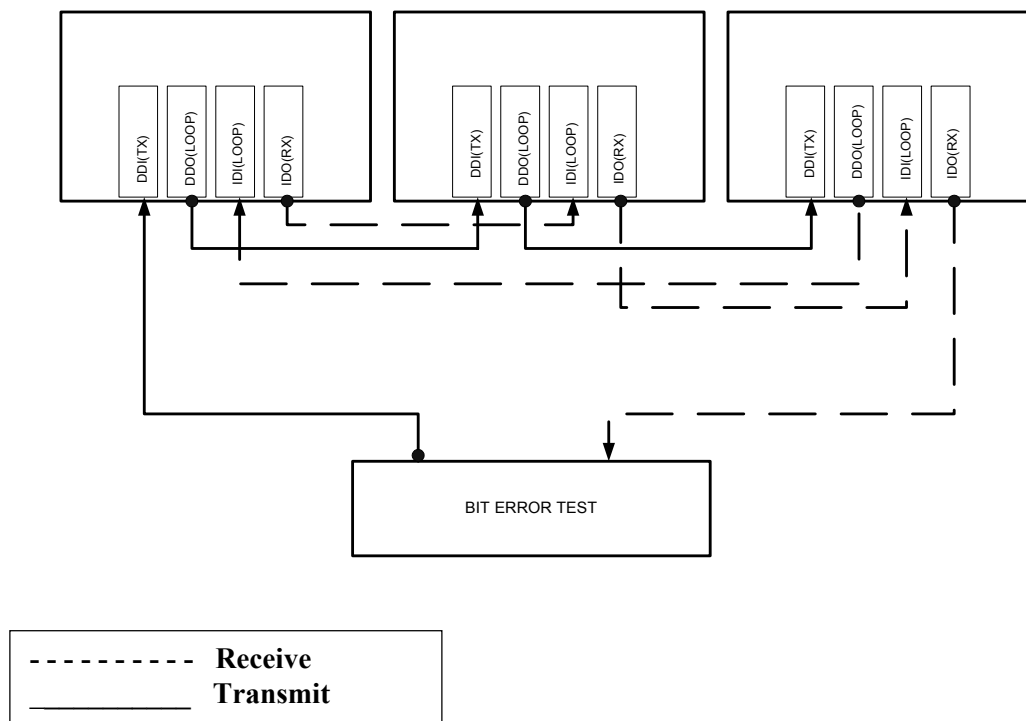
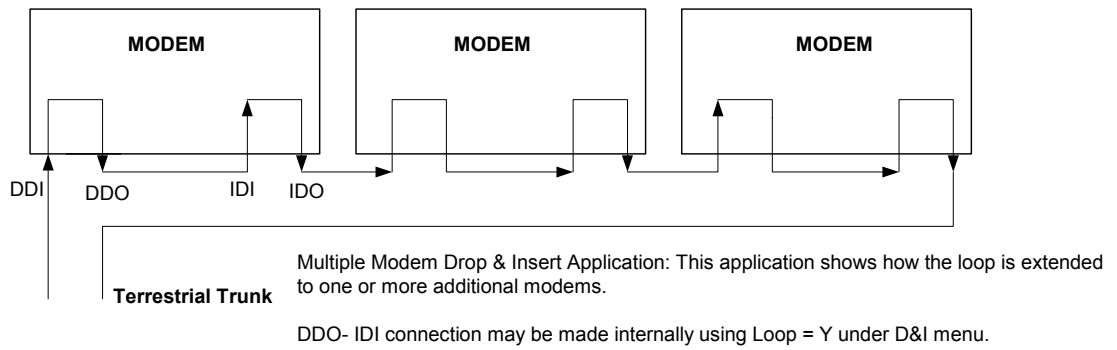

Figure 10-5. Single-Source Multiple Modems (Looming)



**Figure 10-6. Single-Source Multiple Modems (Daisy Chain)**

This page is intentionally left blank.

# Chapter 11. EDMAC CHANNEL

---

## 11.1 Theory Of Operation

As explained earlier, EDMAC is an acronym for **E**mbded **D**istant-end **M**onitor **A**nd **C**ontrol. This is a feature that permits the user to access the M&C features of modems which are at the distant-end of a satellite link.

This is accomplished by adding extra information to the user's data, but in a manner which is completely transparent to the user.

On the transmit side:

The data is split into frames - each frame containing 1008 bits (except Rate 21/44 BPSK Turbo, or when the data rates exceed 2048 kbps, where the frame length is 2928 bits, and Rate 5/16 BPSK Turbo where the frame length is 3072 bits). 48 bits in each frame are overhead, and the rest of these bits are the user's data. This increases the rate of transmission by 5% (approximately 1.5% for the Turbo BPSK cases, and for all data rates greater than 2.048 Mbps). For example, if the user's data rate is 64 kbps, the actual transmission rate will now be at 67.2 kbps.

At the start of each frame, a 12-bit synchronization word is added. This allows the demodulator to find and lock to the start of frame. At regular intervals throughout the frame, additional data bytes and flag bits are added (a further 36 bits in total). It is these additional bytes that convey the M&C data.

When framing is used, the normal V.35 scrambler is no longer used. This V.35 approach is called 'self synchronizing', because in the receiver, no external information is required in order for the de-scrambling process to recover the original data. The disadvantage of this method is that it multiplies errors. On average, if one bit error is present at the input of the descrambler, 3 output errors are generated. However, there is an alternative when the data is in a framed format. In this case, a different class of scrambler may be used - one which uses the start of frame information to start the scrambling process at an exact

known state. In the receiver, having synchronized to the frame, the de-scrambler can begin its processing at exactly the right time. This method does not multiply errors, and therefore has a clear advantage over V.35 scrambling. This is fortunate, as there is a penalty to be paid for adding the framing. By adding the extra 5% to the transmitted data rate, the effective  $E_b/N_0$  seen by the user will degrade by a factor of  $10\log(1.05)$ , or 0.21 dB (0.07dB in the case of the two BPSK Turbo rates). The use of an externally synchronized scrambler and descrambler almost exactly compensates for this degradation. The net effect is that the user will see effectively identical BER performance whether framing is used or not.

On the receive side:

When the demodulator locks to the incoming carrier, it must go through the additional step of searching for, and locking to the synchronization word. This uniquely identifies the start of frame, and permits the extraction of the overhead bytes and flag bits at the correct position within the frame. In addition, the start of frame permits the de-scrambler to correctly recover the data. The user's data is extracted, and sent through additional processing, in the normal manner. The extracted overhead bytes are examined to determine if they contain valid M&C bytes.

---

## 11.2 M&C Connection

Data to be transmitted to the distant-end is sent to a local unit via the remote control port. A message for the distant-end is indistinguishable from a 'local' message - it has the same structure and content, only the address will identify it as being for a distant-end unit.

Before the M&C data can be successfully transmitted and received, pairs of units must be split into EDMAC Masters and EDMAC Slaves. Masters are local to the M&C Computer, and Slaves are distant-end.

Now, a unit that has been designated an EDMAC master not only responds to its own unique bus address, but it will also be configured to listen for the address that corresponds to its EDMAC Slave. When a complete message packet has been received by the EDMAC Master, it will begin to transmit this packet over the satellite channel, using the overhead bytes that become available.

**Note:** The 'normal' protocol for the message packet is not used over the satellite path, as it is subject to errors. For this reason, a much more robust protocol is used which incorporates extensive error checking.

At the distant-end, the EDMAC slave, configured for the correct address, receives these bytes, and when a complete packet has been received, it will take the action requested, and then send the appropriate response to the EDMAC Master, using the return overhead path on the satellite link. The EDMAC Master assembles the complete packet, and transmits the response back to the M&C Computer.



Apart from the round-trip satellite delay, the M&C Computer does not see any difference between local and distant-end units - it sends out a packet, addressed to a particular unit, and gets back a response. It can be seen that the EDMAC Master simply acts as forwarding service, in a manner which is completely transparent.

This approach does not require any additional cabling - connection is made using the normal M&C remote port. Furthermore, the user does not have to worry about configuring the baud rate of the M&C connection to match the lowest data rate modem in the system. The M&C system can have mixed data-rate modems, from 2.4 kbps to 2048 kbps, and still run at speeds in excess of 19,200 baud. It should be pointed out that at 2.4 kbps, the effective throughput of the overhead channel is only 11 async characters/second. For a message of 24 bytes, the time between sending a poll request and receiving a response will be around 5 seconds. (Note that when either of the BPSK Turbo rates is in use, the overhead rate is reduced by a factor of three, and therefore the response time will be around 15 seconds.)

---

### 11.3 Setup Summary

To access a distant-end unit:

- Designate a Master/Slave pair - Master at the local-end, Slave at the distant-end.
- On the local-end unit, enable framing, and EDMAC, define the unit as MASTER, then enter the bus address. This is constrained to be 'base 10' meaning that only addresses such as 10, 20, 30, 40 etc, are allowed.
- Choose a unique bus address for the distant-end. This should normally be set to the 'base 10' address + 1. For example, if the MASTER unit is set to 30, choose 31 for the distant-end unit.
- On the distant-end unit, enable framing, and EDMAC, define the unit as SLAVE, then enter the bus address. The orange EDMAC Mode LED should be illuminated.
- Set the local-end unit to RS485 remote control, and set the bus address of this local unit. The orange Remote Mode LED should be illuminated.
- Once the satellite link has been established, connect the M&C Computer, and begin communications, with both the local and distant end units.

**NOTE:** EDMAC modes are fully compatible with AUPC modes.

---

## 11.4 Drop & Insert ++

A new variation of EDMAC is available with D&I++ framing. With this, each frame contains 2944 bits, with 64 overhead bits and 2880 user data bits. The portion of the overhead used for the EDMAC link performs identically to that of the EDMAC frame, but because D&I++ uses a smaller overhead, the two modes are not compatible with each other.

# Chapter 12. AUTOMATIC UPLINK POWER CONTROL

---

## 12.1 Introduction

Automatic Uplink Power Control (AUPC) is a feature whereby a local modem is permitted to adjust its own output power level in order to attempt to maintain the Eb/No at the remote modem.



*The user **MUST** obtain permission from the Satellite Operator to use this feature.*

*Improper use of this feature could result in a transmitting terminal seriously exceeding its allocated flux density on the Operator's satellite. This could produce interference to other carriers, and could cause transponder saturation problems*

To accomplish this, either the EDMAC or D&I++ framing types may be used. The remote modem constantly sends back information about the demodulator Eb/No using reserved bytes in the overhead structure. The local modem then compares this value of Eb/No with a pre-defined target value. If the Remote Eb/No is below the target, the local modem will increase its output power, creating a closed-loop feedback system over the satellite link. A particularly attractive benefit of this feature is that whenever framed operation is selected, the remote demodulator's Eb/No can be viewed from the front panel display of the local modem. Note that both EDMAC and AUPC can be used simultaneously with either framing type.

There are several important parameters associated with this mode of operation, and the user needs to understand how the AUPC feature works, and the implications of setting these parameters.

---

## 12.2 Setting AUPC Parameters

- 1) The user, under the menu (**CONFIG, MODE**) first ensures that EDMAC is selected. EDMAC may be selected as IDLE, or the unit may be defined as an EDMAC Master or Slave. The important consideration is that EDMAC framing should be enabled.
- 2) The user should verify that the remote modem also has EDMAC framing enabled.
- 3) The user, under the menu (**CONFIG, TX, POWER**) sets the nominal output power of the modem. This is done by selecting the MANUAL mode, then editing the TX output power level displayed.
- 4) The user will then select AUPC as the operating mode. At this point the user will be prompted to define four key parameters:

### 12.2.1 Target Eb/No

This is value of Eb/No that the user desires to keep constant at the remote modem.

If the Eb/No exceeds this value, the AUPC control will reduce the TX output power, but will never drop below the nominal value set.

If the Eb/No falls below this value, the AUPC control will increase the TX output power, but will never exceed the value determined by the parameter MAX RANGE.

- The minimum value the user can enter is 0.0 dB
- The maximum value the user can enter is 9.9 dB
- The default value is 3.0 dB
- The resolution is 0.1 dB

### 12.2.2 Max Range

This defines how much the modem is permitted to increase the output level, under AUPC control.

- The minimum value the user can enter is 0 dB
- The maximum value the user can enter is 9 dB
- The default value is 1 dB
- The resolution is 1 dB

### 12.2.3 Alarm

This parameter defines how the user wants the modem to act if, under AUPC control, the maximum power limit is reached.

The two choices are:

- NONE (no action)
- TX ALARM (generate a TX alarm)

The default setting is NONE.

### 12.2.4 Demod Unlock

This defines the action the modem will take if the remote demodulator loses lock.

The two choices are:

- NOMINAL (reduce the TX Output Power to the nominal value)
- MAXIMUM (increase the TX Output Power to the maximum value permitted by the parameter MAX RANGE)

The default setting is NOMINAL.

(Note that if the local demod loses lock, the modem will automatically move its output power to the nominal value.)

---

## 12.3 Compensation Rate

As with any closed-loop control system, the loop parameters must be chosen to ensure stability at all times. Several features have been incorporated to ensure that the AUPC system does overshoot, or oscillate.

- First, the rate at which corrections to the output power can be made is fixed at once every 4 seconds. This takes into account the round trip delay over the satellite link, the time taken for a power change to be reflected in the remote demodulator's value of  $E_b/N_0$ , and other processing delays in the modems.
- Second, if the comparison of actual and target  $E_b/N_0$  yields a result that requires a change in output power, the first correction made will be 80% of the calculated step. This avoids the possibility of overshoot. Subsequent corrections are made until the difference is less than 0.5 dB. At this point, the output power is only changed in increments of 0.1 dB, to avoid 'hunting' around the correct set point.

---

## 12.4 Monitoring

The remote demodulator's value of  $E_b/N_0$  can be monitored at all times, either from the front panel (**MONITOR, AUPC**) or via the remote control interface. The resolution of the reading is 0.2 dB. For all values greater than or equal to 16 dB, the value 16.0 dB will be displayed. As long as framing is enabled, the value will still be available, even though AUPC may be disabled.

Also displayed is the current value of TX power increase. If EDMAC framing is enabled, but AUPC is disabled, this will indicate 0.0 dB. This value is also available via the remote control interface.



***Comtech EF Data strongly cautions against the use of large values of permitted power level increase under AUPC control. Users should consider using the absolute minimum range necessary to improve rain-fade margin.***

# Chapter 13. ESC++

---

## 13.1 Introduction

The ESC++ mode of operation is a new, closed network frame structure which combines Automatic Uplink Power Control (AUPC) with a high speed asynchronous order-wire channel. The AUPC works identically to that offered with EDMAC and D&I++ framing, but is not compatible with either. This is because ESC++ framing uses a different overhead percentage than the other closed network framing modes.

*In order to use this feature, Firmware Version 2.0.1 (or higher) must be installed.*

---

## 13.2 Overhead Details

Baud rates from 1200 to 38400 bits/sec are offered using RS-232 format. As with the main remote port (P4B), three data formats are available: 8N1, 7E2 and 7O2. Pins 5 and 6 of P3A are the input and output, respectively, for this data channel. Because 38.4 kbaud is the maximum rate available, the actual overhead percentage for ESC++ framing changes as the data rate increases, thereby saving bandwidth at high data rates. The added overhead is as follows:

<u>Data rate</u>	<u>Overhead ratio (percentage)</u>
64 kbps to < 768 kbps	19/17 (11.76%)
768 kbps to 1.5 Mbps	12/11 (9.09%)
> 1.5 Mbps to 2.5 Mbps	29/27 (7.4%)
> 2.5 Mbps to 7 Mbps	19/18 (5.56%)
> 7 Mbps	64/63 (1.58%)

Note that 64 kbps is the minimum data rate allowable with ESC++. Depending upon code rate and modulation used, the modem's maximum data rate of 20 Mbps may be used with ESC++. In all cases, if the Reed-Solomon outer codec is used, the 126/112 ratio is employed with ESC++. The new frame structure may be used with any FEC codec type available with the CDM-600.

### 13.3 Available Baud Rates

At the lowest data rates, the 11.76% overhead may not allow all baud rates. The following table shows available rates:

<u>Data rate</u>	<u>Baud rates available</u>
64 to 127.999 kbps	1200, 2400, 4800
128 to 191.999 kbps	1200 to 9600
192 to 255.999 kbps	1200 to 14400
256 to 383.999 kbps	1200 to 19200
384 to 511.999 kbps	1200 to 28800
512 kbps and above	1200 to 38400

### 13.4 Configuration

To use this mode, the user should select **ESC++** from the **CONFIG, MODE** menu. The baud rate and async character format are then selected from the **CONFIG, MISC, HIGH-RATE ESC** menu. This is described in Chapter 6 (Front Panel Operations).

### 13.5 Effect on Eb/No performance

Because, particularly at lower data rates, where the percentage overhead is large, the increase in transmitted data rate will cause a decrease in the Eb/No performance. Therefore, all of the published data concerning BER versus Eb/No needs to be modified according to the table below:

<u>Data rate</u>	<u>Overhead ratio (percentage)</u>	<u>Eb/No degradation</u>
64 kbps to < 768 kbps	19/17 (11.76%)	0.48 dB
768 kbps to 1.5 Mbps	12/11 (9.09%)	0.38 dB
> 1.5 Mbps to 2.5 Mbps	29/27 (7.4%)	0.31 dB
> 2.5 Mbps to 7 Mbps	19/18 (5.56%)	0.23 dB
> 7 Mbps	64/63 (1.58%)	0.07 dB

The degradation is simply  $10 * \log(\text{Overhead ratio})$

The Eb/No displayed by the modem (**MONITOR, RX-PARAMETERS**) takes this into account in the value that is calculated.



# Chapter 14. FLASH UPGRADING

The CDM-600 eliminates the need for updating firmware by physically replacing EPROMs. Instead, the CDM-600 modem uses ‘flash memory’ technology internally, and new firmware can be uploaded to the unit from an external PC, as follows:

Go to: [www.comtechefdata.com](http://www.comtechefdata.com)  
Click on: downloads  
Click on: flash upgrades

This makes software upgrading very simple, and updates can now be sent via the Internet, E-mail, or on disk. The upgrade can be performed without opening the unit, by simply connecting the modem to the serial port of a computer.

The cable to connect the PC to the modem is the same as is used for normal EIA-232 remote control, and comprises 3-wires between 9 pin ‘D’ type female connectors. This is shown in Appendix A.

Comtech EF Data will distribute a free software utility, that is designed to run under Windows 95/98® or Windows NT®. This utility program is called **600Flash.exe**, and should be copied to the user’s computer hard disk. Along with this, the user will receive the latest firmware file (for example, F1422AD.ccc), which the user should copy to the same sub-directory (folder).

Before initiating uploading, the 25-pin data connector should be disconnected from the modem. The user then connects the modem remote control port to an unused serial port on the user’s computer, and executes the program. The user should follow the instructions presented on the screen, and the upload will take place automatically. Following the successful upload process, the modem will automatically re-start, running the new version of firmware. During this process, the non-volatile RAM, storing the configuration of the modem, will be erased, so the user is then required to re-enter the desired configuration parameters.

Full on-line help is provided with **600Flash.exe**, but if users experience a problem, or have a question, they should contact Comtech EF Data Customer Support department.



**The Remote Control port EIA-232 lines used for Flash upgrading also are connected to the Primary 25-pin data connector (P3B), and are used when 1:N Redundancy Switch is connected. Please ensure that NOTHING is connected to P3B pins 4, 21 and 22 – if these pins are used, the EIA-232 remote control port will not function, and Flash upgrading will be impossible.**

# Chapter 15. SUMMARY OF SPECIFICATIONS

## 15.1 Modulator

<b>Modulation</b>	BPSK, QPSK, OQPSK, 8-PSK, 8-QAM and 16-QAM
<b>Symbol rate range</b>	4.8 ksps to 10.0 Msps
<b>Data rate range</b>	See Section 14.9
<b>Operating modes</b>	<p>Open Network, per Intelsat IESS-308/309/310/314 (IDR, IBS/SMS)  E1/T1 Drop and Insert  Transparent, Closed Network, IESS-315 (VSAT Turbo)  Proprietary EDMAC framed mode:  * 5% overhead - all modes except BPSK Turbo, Rate 1/2 OQPSK Turbo, and data rates &lt; 2.048 Mbps  * 1.5% overhead - Rate 21/44, 5/16 Turbo, Rate 1/2 OQPSK Turbo, and all other rates &gt;2.048 Mbps</p> <p>R-S Outer Codec  Turbo Product Codec – Low Rate, 1<sup>st</sup> Generation (optional):  * Rate 5/16 BPSK  * Rate 21/44 BPSK  * Rate 3/4 QPSK/OQPSK/8-PSK/16-QAM</p> <p>Turbo Product Codec – High Rate, 2<sup>nd</sup> Generation (optional):  * Rate 21/44 BPSK  * Rate 5/16 BPSK  * Rate 1/2 QPSK/OQPSK (exact Code Rate is actually 0.477)  * Rate 3/4 QPSK/OQPSK/8-PSK/16-QAM  * Rate 7/8 QPSK/OQPSK/8-PSK/16-QAM  * Rate 0.95 QPSK/OQPSK/8-PSK (exact Code Rate is actually 0.944)</p> <p>LDPC Codec (optional – includes all 2<sup>nd</sup> Generation TPC modes):  * Rate 1/2 BPSK/QPSK/OQPSK  * Rate 2/3 QPSK/OQPSK/8-PSK/8-QAM  * Rate 3/4 QPSK/OQPSK/8-PSK/8-QAM/16-QAM</p> <p>Automatic Uplink Power Control (AUPC) mode  High Rate ESC (<b>FAST</b>, with Firmware version. 1.3.1 or higher)  ESC++ (with firmware version 2.0.1 or higher)  Drop &amp; Insert ++ (with firmware version 1.5.0 or higher)</p>
<b>Transmit filtering</b>	Per INTELSAT IESS-308 (FIR digital filter implementation)

<b>Scrambling</b>	IDR Mode, no RS, - per ITU V.35 (Intelsat variant) IBS mode, no RS - per IESS-309, externally frame synchronized Transparent Closed Network mode, no R-S or Turbo coding - per ITU V.35 (Intelsat variant) EDMAC mode, no R-S coding - externally frame synchronized - proprietary Turbo Product Code mode - externally frame synchronized - proprietary All R-S modes - externally frame synchronized per IESS-308/309/310
<b>FEC</b>	<b>None:</b> Uncoded BPSK/QPSK/OQPSK <b>Viterbi:</b> k=7, per IESS-308/309 BPSK: Rate 1/2 QPSK/OQPSK: Rate 1/2, Rate 3/4 and Rate 7/8 16-QAM: Rate 3/4 and Rate 7/8 (Viterbi plus Reed-Solomon only) <b>Sequential:</b> k=36 (Rate 1/2) per IESS-309 k= 63 (Rate 3/4) per IESS-309 k= 87 (Rate 7/8) <i>Important note: Sequential decoding limits the data rate to a maximum of 2.048 Mbps for OQPSK and 1.024 Mbps for BPSK.</i> <b>Reed-Solomon (Open Network):</b> IDR modes: 225/205 for T1 219/201 for E1 and IESS-310 mode, 194/178 for T2 and E2 IBS modes: 126/112 219/201 for IESS-310 mode <b>Reed-Solomon (Closed Network):</b> 220,200 outer code (transparent mode) 225,205 outer code (transparent mode, EF Data compatible, V.35 scrambling) 126,112 outer code (transparent mode, IBS parameters, D&I++ mode) 219,201 outer code (transparent mode, IESS-310 parameters) 200,180 outer code (EDMAC modes) Interleaver depth = 4 or 8 (Viterbi, depending on mode) Interleaver depth = 8 (Sequential) <b>8-PSK/TCM Rate 2/3 (Trellis): Per IESS-310</b> <b>Turbo Product Codec, Low Rate (1<sup>st</sup> Generation)</b> (Optional plug-in card): Rate 3/4 QPSK/OQPSK/8-PSK/16-QAM - 2 dimensional Rate 21/44 BPSK - 3 dimensional Rate 5/16 BPSK - 3 dimensional <b>Turbo Product Codec, High Rate (2<sup>nd</sup> Generation)</b> (Optional plug-in card): Rate 5/16 BPSK - 2 dimensional Rate 21/44 BPSK - 3 dimensional Rate 1/2 QPSK/OQPSK - 3 dimensional (exact Code Rate is actually 0.477) Rate 3/4 QPSK/OQPSK/8-PSK/16-QAM - 2 dimensional Rate 7/8 QPSK/OQPSK/8-PSK/16-QAM - 2 dimensional Rate 0.95 QPSK/OQPSK/8-PSK - 2 dimensional TPC (exact Code Rate is actually 0.944) <b>Low Density Parity Check (LDPC) Codec</b> (Optional plug-in card): Rate 1/2 BPSK/QPSK/OQPSK Rate 2/3 QPSK/OQPSK/8-PSK/8-QAM Rate 3/4 QPSK/OQPSK/8-PSK/8-QAM/16-QAM
<b>Output frequency</b>	<b>CDM-600:</b> 52 - 88 MHz, 104 - 176 MHz, 100 Hz resolution – units manufactured prior to February 2005 <b>CDM-600(E):</b> 50 - 90 MHz, 100 - 180 MHz, 100 Hz resolution – units manufactured after February 2005 Stability $\pm 1.5$ ppm, 0 to 50°C (32 to 122 °F) (standard stability internal reference) Stability $\pm 0.02$ ppm, 0 to 50°C (32 to 122 °F) ( <b>Optional High-stability internal reference</b> )
<b>Harmonics/spurious</b>	Better than -55 dBc/4 kHz (typically <-60 dBc/4kHz) – measured from 25 to 400 MHz
<b>Transmit on/off ratio</b>	55 dB minimum
<b>Output phase noise</b>	< 0.48 <sup>0</sup> rms double sided, 100 Hz to 1MHz (minimum of 16 dB better overall than the INTELSAT IESS-308/309 requirement)
<b>Output power</b>	0 to -20 dBm, 0.1 dB steps - manual mode. See Automatic Uplink Power Control section also.
<b>Power accuracy</b>	$\pm 0.5$ dB over frequency and temperature
<b>Output impedance</b>	50 and 75 $\Omega$ , front panel selectable 21 dB minimum return loss
<b>Output connector</b>	BNC female
<b>Clocking options</b>	Internal, $\pm 1.5$ ppm or 0.02 ppm (SCT) External, locking over a $\pm 100$ ppm range (TT) Loop timing (Rx satellite clock) - supports asymmetric operation - Rx and Tx data rates do not need to be identical External Clock
<b>External TX Carrier Off</b>	By TTL 'low' signal or external contact closure - hardware function automatically over-rides processor

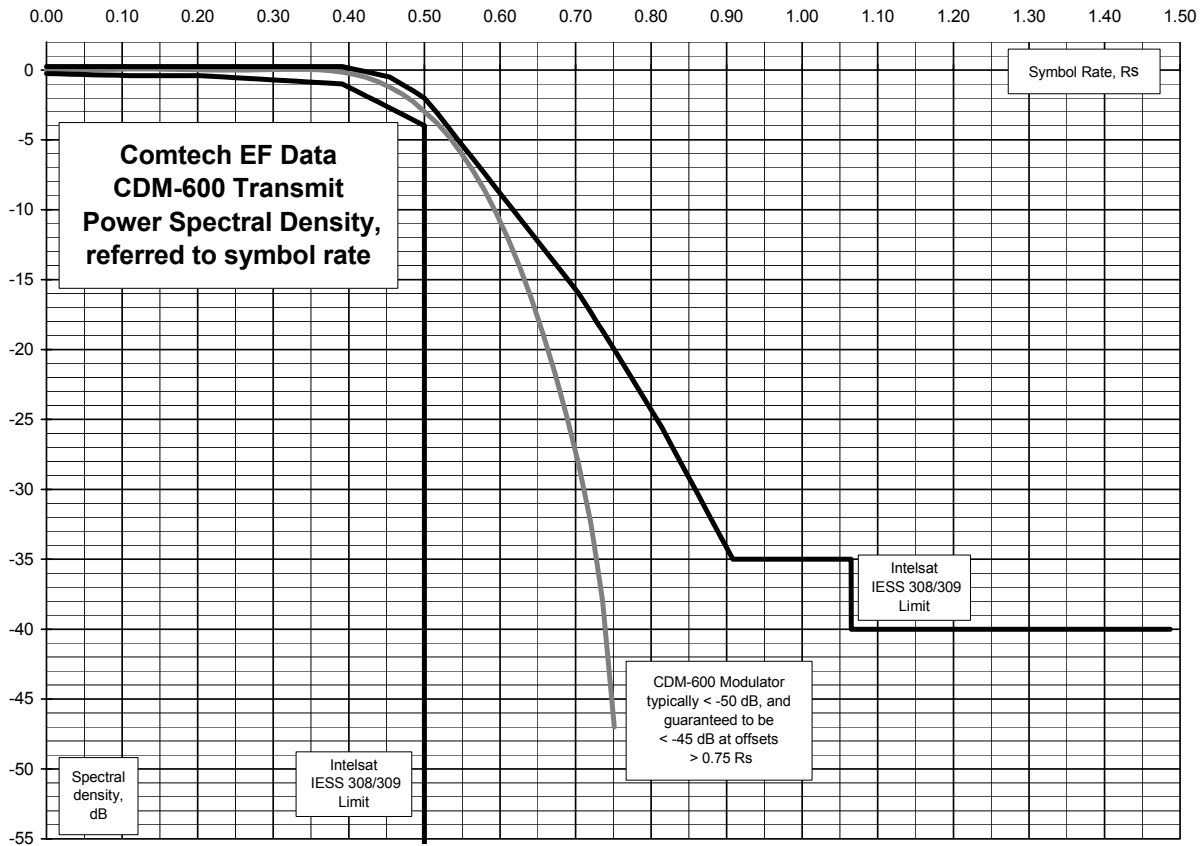

## 15.2 Demodulator

Data rate range, operating modes, de-scrambling, input impedance/return loss etc, as per Modulator

<b>Input power range</b>	-30 to -60 dBm (desired carrier) +35 dBC maximum composite, up to -5 dBm
<b>FEC</b>	<b>Viterbi:</b> 3 bit soft decision <b>Sequential:</b> 2 bit soft decision <b>Trellis:</b> Per IESS-310 <b>Reed-Solomon(Open Network):</b> Per IESS-308/309/310 <b>Reed-Solomon(Closed Network):</b> Proprietary <b>Turbo Product Codec:</b> 6 bit soft decision, proprietary <b>LDPC:</b> 5 bit soft decision, proprietary
<b>Acquisition range</b>	$\pm 1$ to $\pm 32$ kHz, programmable in 1kHz increments
<b>Acquisition time</b>	Highly dependent on data rate, FEC rate, and demodulator acquisition range. <b>Examples:</b> 200 ms average at 64 kbps, R1/2 QPSK, $\pm 32$ kHz acquisition sweep range, 6dB Eb/No 5 s average at 9.6 kbps, R1/2 QPSK, $\pm 10$ kHz, 6dB Eb/No <b>Note</b> that Reed-Solomon increases acquisition time, due to the additional time taken for the RS decoder to declare synchronization.
<b>Clock tracking range</b>	$\pm 100$ ppm min

<b>VITERBI BER performance (met in the presence of two adjacent carriers, each 7 dB higher than the desired carrier)</b>	For: BER=10 <sup>-5</sup>  BER=10 <sup>-6</sup>  BER=10 <sup>-7</sup>	<b>Rate 1/2 (B, Q, OQ)</b> Guaranteed Eb/No: (typical value in parentheses)  5.4 dB (4.9 dB)  6.0 dB (5.5 dB)  6.7 dB (6.2 dB)	<b>Rate 3/4 (Q, OQ)</b> Guaranteed Eb/No: (typical value in parentheses)  6.8 dB (6.3 dB)  7.4 dB (6.9 dB)  8.2 dB (7.7 dB)	<b>Rate 7/8 (Q, OQ)</b> Guaranteed Eb/No: (typical value in parentheses)  7.7 dB (7.2 dB)  8.4 dB (7.9 dB)  9.0 dB (8.6 dB)
<b>SEQUENTIAL @ 64 kbps BER (met in the presence of two adjacent carriers, each 7 dB higher than the desired carrier)</b>	For: BER=10 <sup>-5</sup>  BER=10 <sup>-6</sup>  BER=10 <sup>-7</sup>	<b>Rate 1/2 (B, Q, OQ)</b> GuaranteedEb/No: (typical value in parentheses)  4.8 dB (4.2 dB)  5.2 dB (4.5 dB)  5.6 dB (4.8 dB)	<b>Rate 3/4 (Q, OQ)</b> Guaranteed Eb/No: (typical value in parentheses)  5.8 dB (5.3 dB)  6.4 dB (5.8 dB)  6.9 dB (6.3 dB)	<b>Rate 7/8 (Q, OQ)</b> Guaranteed Eb/No: (typical value in parentheses)  7.0 dB (6.6 dB)  7.5 dB (7.2 dB)  8.0 dB (7.7 dB)
<b>SEQUENTIAL @ 1024 kbps BER (met in the presence of two adjacent carriers, each 7 dB higher than the desired carrier)</b>	For: BER=10 <sup>-5</sup>  BER=10 <sup>-6</sup>  BER=10 <sup>-7</sup>	<b>Rate 1/2 (B, Q, OQ)</b> Guaranteed Eb/No: (typical value in parentheses)  5.2 dB (4.8 dB)  5.7 dB (5.2 dB)  6.1 dB (5.7 dB)	<b>Rate 3/4 (Q, OQ)</b> Guaranteed Eb/No: (typical value in parentheses)  5.9dB (5.5dB)  6.5dB (6.0dB)  7.0dB (6.5dB)	<b>Rate 7/8 (Q, OQ)</b> Guaranteed Eb/No: (typical value in parentheses)  7.2 dB (6.6 dB)  7.7 dB (7.2 dB)  8.3 dB (7.7 dB)
<b>VITERBI and RS 220,200 or 200,180 Outer Code BER (with two adjacent carriers, each 7 dB higher than the desired carrier)</b>	For: BER=10 <sup>-5</sup>  BER=10 <sup>-6</sup>  BER=10 <sup>-7</sup>	<b>Rate 1/2 (B, Q, OQ)</b> Guaranteed Eb/No: (typical value in parentheses)  4.3 dB (4.0 dB)  4.4 dB (4.1 dB)  4.5 dB (4.2 dB)	<b>Rate 3/4 (Q, OQ)</b> Guaranteed Eb/No: (typical value in parentheses)  5.6 dB (4.7 dB)  5.8 dB (4.8 dB)  6.0 dB (5.2 dB)	<b>Rate 7/8 (Q, OQ)</b> Guaranteed Eb/No: (typical value in parentheses)  6.5 dB (6.0 dB)  6.7 dB (6.2 dB)  6.9 dB (6.5 dB)
<b>SEQUENTIAL and RS 220,200 or 200,180 Outer Code @ 512 kbps (two adjacent carriers, each 7 dB higher than the desired carrier)</b>	For:  BER=10 <sup>-7</sup>  BER=10 <sup>-8</sup>	<b>Rate 1/2 (B, Q, OQ)</b> Guaranteed Eb/No: (typical value in parentheses)  4.6 dB (4.3 dB)  4.8 dB (4.5 dB)	<b>Rate 3/4 (Q, OQ)</b> Guaranteed Eb/No: (typical value in parentheses)  5.3 dB (4.9 dB)  5.6 dB (5.3 dB)	<b>Rate 7/8 (Q, OQ)</b> Guaranteed Eb/No: (typical value in parentheses)  6.0 dB (5.7 dB)  6.4 dB (6.1 dB)
<b>8-PSK/TCM CODEC BER (With two adjacent carriers, each 7 dB higher than the desired carrier)</b>	For:  BER=10 <sup>-5</sup>  BER=10 <sup>-7</sup>  BER=10 <sup>-8</sup>	<b>Rate 2/3 8-PSK/TCM</b> Guaranteed Eb/No: (typical value in parentheses)  7.9 dB (7.2 dB)  9.5 dB (8.7 dB)  10.4 dB (9.5dB)	<b>Rate 2/3 8-PSK/TCM w/concatenated RS</b> Guaranteed Eb/No: (typical value in parentheses)  6.3 dB (5.4 dB)  6.7 dB (5.8 dB)  6.9 dB (6.0 dB)	

<b>TURBO PRODUCT CODEC BER</b> <b>Rate 1/2 QPSK</b> <b>Rate 21/44 BPSK</b> <b>Rate 5/16 BPSK BER</b> (With two adjacent carriers, each 7 dB higher than the desired carrier)	For:	<b>Rate 1/2 (Q, OQ)</b> Guaranteed Eb/No: (typical value in parentheses)	<b>Rate 21/44 (B)</b> Guaranteed Eb/No: (typical value in parentheses)	<b>Rate 5/16 (B)</b> Guaranteed Eb/No: (typical value in parentheses)
	BER=10 <sup>-6</sup>	2.9 dB (2.6 dB)	2.8 dB (2.5dB)	2.4 dB (2.1dB)
	BER=10 <sup>-7</sup>	3.1 dB (2.7 dB)	3.1 dB (2.8 dB)	2.6 dB (2.3dB)
	BER=10 <sup>-8</sup>	3.3 dB (2.8 dB)	3.3 dB (2.90dB)	2.7 dB (2.4dB)
<b>TURBO PRODUCT CODEC BER</b> <b>Rate 3/4 QPSK</b> <b>Rate 3/4 8-PSK</b> <b>Rate 3/4 16-QAM BER</b> (With two adjacent carriers, each 7 dB higher than the desired carrier)	For:	<b>Rate 3/4 (Q, OQ)</b> Guaranteed Eb/No: (typical value in parentheses)	<b>Rate 3/4 (8-PSK)</b> Guaranteed Eb/No: (typical value in parentheses)	<b>Rate 3/4 (16-QAM)</b> Guaranteed Eb/No: (typical value in parentheses)
	BER=10 <sup>-6</sup>	3.8dB (3.4dB)	6.2 dB (5.8 dB)	7.4dB (7.0 dB)
	BER=10 <sup>-7</sup>	4.1dB (3.7dB)	6.4 dB (6.0 dB)	7.8 dB (7.3 dB)
	BER=10 <sup>-8</sup>	4.4dB (4.0dB)	6.8 dB (6.3 dB)	8.2 dB (7.7 dB)
<b>TURBO PRODUCT CODEC BER</b> <b>Rate 7/8 QPSK</b> <b>Rate 7/8 8-PSK</b> <b>Rate 7/8 16-QAM BER</b> (With two adjacent carriers, each 7 dB higher than the desired carrier)	For:	<b>Rate 7/8 (Q, OQ)</b> Guaranteed Eb/No: (typical value in parentheses)	<b>Rate 7/8 (8-PSK)</b> Guaranteed Eb/No: (typical value in parentheses)	<b>Rate 7/8 (16-QAM)</b> Guaranteed Eb/No: (typical value in parentheses)
	BER=10 <sup>-6</sup>	4.3 dB (4.0 dB)	7.0 dB (6.6 dB)	8.1 dB (7.7 dB)
	BER=10 <sup>-7</sup>	4.4 dB (4.1 dB)	7.1 dB (6.7 dB)	8.2 dB (7.8 dB)
	BER=10 <sup>-8</sup>	4.5 dB (4.2 dB)	7.2 dB (6.8 dB)	8.3 dB (7.9 dB)
<b>TURBO PRODUCT CODEC BER</b> <b>Rate 0.95 QPSK</b> <b>Rate 0.95 8-PSK BER</b> (With two adjacent carriers, each 7 dB higher than the desired carrier)	For:	<b>Rate 0.95 (Q, OQ)</b> Guaranteed Eb/No: (typical value in parentheses)	<b>Rate 0.95 (8-PSK)</b> Guaranteed Eb/No: (typical value in parentheses)	
	BER=10 <sup>-6</sup>	6.4 dB (6.0 dB)	9.3 dB (8.9 dB)	
	BER=10 <sup>-7</sup>	6.7 dB (6.3 dB)	9.8 dB (9.4 dB)	
	BER=10 <sup>-8</sup>	6.9 dB (6.5 dB)	10.3 dB (9.9 dB)	
<b>16-QAM VITERBI/RS BER</b> (With two adjacent carriers, each 7 dB higher than the desired carrier)	For:	<b>16-QAM Rate 3/4 Viterbi/RS</b> Guaranteed Eb/No: (typical value in parentheses)	<b>16-QAM Rate 7/8 Viterbi/RS</b> Guaranteed Eb/No: (typical value in parentheses)	
	BER=10 <sup>-6</sup>	8.1 dB (7.5 dB)	9.5 dB (9.0 dB)	
	BER=10 <sup>-8</sup>	8.6 dB (8.0 dB)	10.1 dB (9.5 dB)	
<b>LDPC CODEC BER</b> <b>Rate 1/2 B/Q/OQPSK</b> <b>Rate 2/3 Q/OQPSK</b> <b>Rate 1/2 Q/OQPSK</b> (With two adjacent carriers, each 7 dB higher than the desired carrier)	For:	<b>BPSK/QPSK/OQPSK Rate 1/2 LDPC</b> Guaranteed Eb/No: (typical value in parentheses)	<b>QPSK/OQPSK Rate 2/3 LDPC</b> Guaranteed Eb/No: (typical value in parentheses)	<b>QPSK/OQPSK Rate 3/4 LDPC</b> Guaranteed Eb/No: (typical value in parentheses)
	BER=10 <sup>-5</sup>	2.0 dB (1.7 dB)	2.3 dB (2.0 dB)	3.0 dB (2.6 dB)
	BER=10 <sup>-9</sup>	2.3 dB (2.0 dB)	2.7 dB (2.3 dB)	3.3 dB (3.0 dB)

LDPC CODEC BER Rate 2/3 8-PSK Rate 3/4 8-PSK (With two adjacent carriers, each 7 dB higher than the desired carrier)	For:	<b>8-PSK Rate 2/3 LDPC</b> Guaranteed Eb/No: (typical value in parentheses)	<b>8-PSK Rate 3/4 LDPC</b> Guaranteed Eb/No: (typical value in parentheses)	
	BER=10 <sup>-5</sup>	-	5.7 dB (5.3 dB)	
LDPC CODEC BER Rate 2/3 8-QAM Rate 3/4 8-QAM (With two adjacent carriers, each 7 dB higher than the desired carrier)	For:	<b>8-QAM Rate 2/3 LDPC</b> Guaranteed Eb/No: (typical value in parentheses)	<b>8-QAM Rate 3/4 LDPC</b> Guaranteed Eb/No: (typical value in parentheses)	
	BER=10 <sup>-5</sup>	4.6 dB (4.2 dB)	5.2 dB (4.7 dB)	
LDPC CODEC BER Rate 3/4 16-QAM (With two adjacent carriers, each 7 dB higher than the desired carrier)	For:	<b>16-QAM Rate 3/4 LDPC</b> Guaranteed Eb/No: (typical value in parentheses)		
	BER=10 <sup>-5</sup>	6.8 dB (6.2 dB)		
Plesiochronous/ Doppler Buffer	For:			
	BER=10 <sup>-5</sup>	7.1 dB (6.8 dB)		
Monitor Functions	Selectable size of 64 to 262,144 bits, in 16-bit steps (with added limitations for G.704 frame boundaries) Size selection is displayed in bytes and milliseconds Supports asymmetric operation - when buffer is clocked from Tx clock, Rx and Tx rates do not need to be identical			
	Eb/No estimate, 2 to 16 dB (± 0.25 dB accuracy) Corrected Bit Error Rate, 1E-3 to 1E-10 Frequency offset, ± 32 kHz range, 100 Hz resolution Buffer fill state, in percent Receive signal level (-20 to -60 dBm, accuracy is ± 2.5 dB)			

## 15.3 Data Interfaces

<b>Primary Data</b> (3 selectable modes)	RS-422/EIA-530 DCE (Rates up to 10 Mbps) (also supports X.21 DCE & DTE and 8k ESC orderwire for IDR) V.35 DCE (Rates up to 10 Mbps) Synchronous EIA-232 (Rates up to 300 kbps) LVDS serial (Rates up to 20 Mbps) HSSI - <b>Requires optional CIC-20 Converter</b> (Rates up to 20 Mbps)	25-pin D-sub (female)
<b>G.703 (Tx In, Drop Out, Insert In, Rx Out)</b>	1.544 Mbps T1 (Balanced 100 Ω) 6.312 Mbps T2 (unbalanced 75 Ω or balanced 110 Ω) 2.048 Mbps E1 (unbalanced 75 Ω or balanced 120 Ω) 8.448 Mbps E2 (unbalanced 75 Ω) <b>Note:</b> All Drop and Insert modes are a <b>FAST</b> option.	15-pin D-sub (female) or BNC (female)
<b>External Reference In</b>	2.4 kHz - 10 MHz, in 1 Hz steps (locks baseband clocks only) TTL level (unbalanced) or sine wave @ 0dBm nominal	BNC (female)
<b>Overhead Data</b>	RS-422 octet clocks for IDR ESC & IBS RS-422 IDR 64 kbps ESC data & clock RS-232 IBS ESC data & clock RS-422 External Clock input IDR BWA Inputs RS-232 High Rate ESC data ( <b>FAST</b> , with Firmware V. 1.3.1 or higher) RS-232 ESC++ data (with Firmware V. 2.0.1 or higher)	25-pin D-sub (male)



<b>Modem Alarms</b>	Relay outputs (Tx, Rx & unit faults) Demodulator I & Q test outputs (constellation) Demodulator Rx Signal Level output (0 to 2.5 volts) External carrier off input	15-pin D-sub (male)
<b>IDR BWA Outputs</b>	4 backward alarm Form C relay outputs	15-pin D-sub (female)
<b>Remote Control</b>	RS-232 or RS-485 modem control and monitoring	9-pin D-sub (male)
<b>ADPCM Audio Interface</b>	2 audio channels, each occupying 32 kbps bandwidth as part of IDR overhead or as a 64 kbps primary data rate option. 600 $\Omega$ balanced – 0 dBm0 nominal, -6 to +8 dB, 2 dB steps	9-pin D-sub (female)
<b>Auxiliary Serial</b>	RS-232 link to other modem in 1:1 pair, via CRS-150	USB Type B Socket

## 15.4 Automatic Uplink Power Control

<b>Operating Mode</b>	Requires Closed Network Framed mode (EDMAC, D&I++, or ESC++) for transport of Eb/No information from remote modem (EDMAC can be enabled or disabled)
<b>Target Eb/No range</b>	0 to 9.9 dB at remote demod (default is 4.0 dB)
<b>Max AUPC range</b>	0 to 9 dB (default is 3 dB)
<b>Monitor functions</b>	Remote demod Eb/No Tx power level increase (front panel or via remote control interface)

## 15.5 Framing Summary

	Transparent	EDMAC	IDR	IBS	D&I	D&I++	ESC++
<b>Overhead added</b>	None	To 2 Mbps: 1.5% Above 2 Mbps: 1.5% (see Note 2)	Fixed 96 kHz	1/15 of front panel data rate	1/15 of front panel data rate Terrestrial is T1 or E1	1/45 of front panel data rate Terrestrial is T1 or E1	Variable: between 11.76% at 64 kbps to 1.58% above 7 Mbps
<b>Available data rates and format</b>	All rates and formats	All rates and formats	T1, E1, T2 and E2; all formats	64 to 2048 kbps only; all formats	Specific multiples of 64 kbps only	Any multiple of 64 kbps, up to $n = 24$ .	All rates and formats
<b>Overhead components</b>	None	Remote control link between modems' processor plus AUPC	EIA-422 ESC (8 kbps) EIA-422 ESC (64 kbps or 2 audio links) 4 BW alarms	EIA-232 Earth station link at 1/480 <sup>th</sup> of primary data rate One BW alarm	EIA-232 Earth station link at 1/480 <sup>th</sup> of primary data rate One BW alarm	Same as EDMAC, plus EIA-232 Earth station link at 1/576 <sup>th</sup> of primary data rate	EIA-232 Earth station link at variable rate, plus AUPC
<b>Additional Reed-Solomon Overhead</b>	200/180 219/201 for IESS-310 mode	200/180	T1 = 225/205 E1 = 219/201 and IESS-310 mode T2/E2 = 94/178	126/112 219/201 for IESS-310 mode	126/112 219/201 for IESS-310 mode	126/112	126/112
<b>Scrambling (see Note 1)</b>	Basic ITU V.35 (Intelsat)	Proprietary scrambler	Basic ITU V.35 (Intelsat)	IESS-309 scrambler	IESS-309 scrambler	Basic ITU V.35 (Intelsat)	Proprietary scrambler

**Notes:**

1. Reed-Solomon is Off.
2. 1.5 % for Rates 5/16 or 21/44 BPSK Turbo, Rate 1/2 QPSK/OQPSK Turbo, and all rates > 2 Mbps

## 15.6 Data Rate Ranges

Code Rate/Modulation	FEC Type	Data Rate Range
Uncoded BPSK	None	4.8 kbps to 10.0 Mbps
Uncoded QPSK/OQPSK	None	9.6 kbps to 20 Mbps
Rate 1/2 BPSK	Viterbi	2.4 kbps to 5.0 Mbps
Rate 1/2 BPSK	Sequential	2.4 kbps to 1.024 Mbps
Rate 1/2 BPSK	Viterbi with R-S	2.4 kbps to 4.444 Mbps
Rate 1/2 BPSK	Sequential with R-S	2.4 kbps to 1.024 Mbps
Rate 1/2 QPSK/OQPSK	Viterbi	4.8 kbps to 10.0 Mbps
Rate 1/2 QPSK/OQPSK	Sequential	4.8 kbps to 2.048 Mbps
Rate 1/2 QPSK/OQPSK	Viterbi with R-S	4.8 kbps to 8.888 Mbps
Rate 1/2 QPSK/OQPSK	Sequential with R-S	4.8 kbps to 2.048 Mbps
Rate 3/4 QPSK/OQPSK	Viterbi	7.2 kbps to 15 Mbps
Rate 3/4 QPSK/OQPSK	Sequential	7.2 kbps to 2.048 Mbps
Rate 3/4 QPSK/OQPSK	Viterbi with R-S	7.2 kbps to 13.333 Mbps
Rate 3/4 QPSK/OQPSK	Sequential with R-S	7.2 kbps to 2.048 Mbps
Rate 7/8 QPSK/OQPSK	Viterbi	8.4 kbps to 17.5 Mbps
Rate 7/8 QPSK/OQPSK	Sequential	8.4 kbps to 2.048 Mbps
Rate 7/8 QPSK/OQPSK	Viterbi with R-S	8.4 kbps to 15.555 Mbps
Rate 7/8 QPSK/OQPSK	Sequential with R-S	8.4 kbps to 2.048 Mbps
Rate 2/3 8-PSK	TCM	9.6 kbps to 20.0 Mbps
Rate 2/3 8-PSK	TCM with R-S	9.6 kbps to 17.777 Mbps
Rate 3/4 16-QAM	Viterbi with R-S	14.4 kbps to 20.0 Mbps
Rate 7/8 16-QAM	Viterbi with R-S	16.8 kbps to 20.0 Mbps
Rate 21/44 BPSK	TPC	4.8 kbps to 3.2 Mbps <i>(to 4.77 Mbps with High Rate Turbo card)</i>
Rate 5/16 BPSK	TPC	4.8 kbps to 2.048 Mbps <i>(to 3.12 Mbps with High Rate Turbo card)</i>
Rate 3/4 QPSK/OQPSK	TPC	7.2 kbps to 5.0 Mbps <i>(to 15 Mbps with High Rate Turbo card)</i>
Rate 3/4 8-PSK	TPC	10.8 kbps to 5.0 Mbps <i>(to 20 Mbps with High Rate Turbo card)</i>
Rate 3/4 16-QAM	TPC	14.4 kbps to 5.0 Mbps <i>(to 20 Mbps with High Rate Turbo card)</i>
Rate 1/2 QPSK/OQPSK	TPC	4.8 kbps to 9.54 Mbps <i>(High Rate Turbo card only)</i>
Rate 7/8 QPSK/OQPSK	TPC	8.4 kbps to 17.5 Mbps <i>(High Rate Turbo card only)</i>
Rate 0.95 QPSK/OQPSK	TPC	9.1 kbps to 18.888 Mbps <i>(High Rate Turbo card only)</i>
Rate 7/8 8-PSK	TPC	12.6 kbps to 20 Mbps <i>(High Rate Turbo card only)</i>
Rate 0.95 8-PSK	TPC	13.6 kbps to 20 Mbps <i>(High Rate Turbo card only)</i>
Rate 7/8 16-QAM	TPC	16.8 kbps to 20 Mbps <i>(High Rate Turbo card only)</i>
Rate 1/2 BPSK	LDPC	2.4 kbps to 5.0 Mbps
Rate 1/2 QPSK/OQPSK	LDPC	4.8 kbps to 10.0 Mbps
Rate 2/3 QPSK/OQPSK	LDPC	6.4 kbps to 13.333 Mbps
Rate 3/4 QPSK/OQPSK	LDPC	7.2 kbps to 15.0 Mbps
Rate 2/3 8-PSK/8-QAM	LDPC	9.6 kbps to 19.0 Mbps
Rate 3/4 8-PSK/8-QAM	LDPC	10.8 kbps to 20.0 Mbps
Rate 3/4 16-QAM	LDPC	14.4 kbps to 20.0 Mbps
<b>Important Notes:</b>		
1) If EDMAC framing is employed, the upper data rate will be reduced by 5% for data rates up to 2.048 Mbps, and by 1.58% for data rates above 2.048 Mbps)		
2) If ESC++ framing is employed, the upper data rate will be reduced 1.58%.		

## 15.7 Miscellaneous

<b>Front panel</b>	Tactile keypad, 6 keys (Up/Down, Left/Right, Enter/Clear) Vacuum Fluorescent Display (blue) - 2 lines of 40 characters
<b>Loopbacks</b>	Internal IF loopback, RF loopback, digital loopback, and inward/outward loopback
<b>Fault relays</b>	Hardware fault, Rx and Tx Traffic Alarms, Open Network Backward Alarms
<b>M&amp;C Interface</b>	EIA-232 and EIA-485 (addressable multidrop, 2-wire or 4-wire)
<b>M&amp;C Software</b>	SATMAC or CMCS software for control of local and distant units
<b>Dimensions</b>	1U high, 12 inches (305 mm) deep
<b>Weight</b>	10 lbs (4.5 kgs) max
<b>AC consumption</b>	25 watts (typical) 40 watts (maximum)
<b>Operating voltage</b>	100 - 240 volts AC, +6%/-10% - autosensing (total absolute max. range is 90 - 254 volts AC)
<b>Operating temperature</b>	0 to 50°C (32 to 122°F)

## 15.8 Approvals

<b>"CE" as follows:</b>	EN 55022 Class B (Emissions) EN 50082-1 (Immunity) EN 60950 (Safety)	EN 61000-3-2 EN 61000-3-3 EN 61000-4-2 EN 61000-4-4 EN 61000-4-5	EN 61000-4-6 EN 61000-4-8 EN 61000-4-9 EN 61000-4-11 EN 61000-4-13
<b>FCC</b>	FCC Part 15 Class B		

This page is intentionally left blank.

# Chapter 16. REMOTE CONTROL

---

## 16.1 Introduction

This section describes the protocol and message command set for remote monitor and control of the CDM-600 Modem.

The electrical interface is either an EIA-485 multi-drop bus (for the control of many devices) or an EIA-232 connection (for the control of a single device), and data is transmitted in asynchronous serial form, using ASCII characters. Control and status information is transmitted in packets, of variable length, in accordance with the structure and protocol defined in later sections.

---

## 16.2 EIA-485

For applications where multiple devices are to be monitored and controlled, a full-duplex (or 4-wire) EIA-485 is preferred. Half-duplex (2-wire) EIA-485 is possible, but is not preferred.

In full-duplex EIA-485 communication there are two separate, isolated, independent, differential-mode twisted pairs, each handling serial data in different directions. It is assumed that there is a 'controller' device (a PC or dumb terminal), which transmits data, in a broadcast mode, via one of the pairs. Many 'target' devices are connected to this pair, which all simultaneously receive data from the controller. The controller is the only device with a line-driver connected to this pair - the target devices only have line-receivers connected.

In the other direction, on the other pair, each target has a tri-stateable line driver connected, and the controller has a line-receiver connected. All the line drivers are held in high-impedance mode until one (and only one) target transmits back to the controller.

Each target has a unique address, and each time the controller transmits, in a framed 'packet' of data, the address of the intended recipient target is included. All of the targets receive the packet, but only one (the intended) will reply. The target enables its output line driver, and transmits its return data packet back to the controller, in the other direction, on the physically separate pair.

EIA 485 (full duplex) summary:

- Two differential pairs - one pair for controller to target, one pair for target to controller.
- Controller-to-target pair has one line driver (controller), and all targets have line-receivers.
- Target-to-controller pair has one line receiver (controller), and all targets have tri-state drivers.

---

### **16.3 EIA-232**

This is a much simpler configuration in which the controller device is connected directly to the target via a two-wire-plus-ground connection. Controller-to-target data is carried, via EIA-232 electrical levels, on one conductor, and target-to-controller data is carried in the other direction on the other conductor.

---

### **16.4 Basic Protocol**

Whether in EIA-232 or EIA-485 mode, all data is transmitted as asynchronous serial characters, suitable for transmission and reception by a UART. In this case, the asynchronous character formats include 7O2, 7E2, and 8N1. The baud rate may vary between 1200 and 38,400 baud.

All data is transmitted in framed packets. The controller is assumed to be a PC or ASCII dumb terminal, which is in charge of the process of monitor and control. The controller is the only device that is permitted to initiate, at will, the transmission of data. Targets are only permitted to transmit when they have been specifically instructed to do so by the controller.

All bytes within a packet are printable ASCII characters, less than ASCII code 127. In this context, the Carriage Return and Line Feed characters are considered printable.

All messages from controller to target require a response (with one exception). This will be either to return data that has been requested by the controller, or to acknowledge reception of an instruction to change the configuration of the target. The exception to this is when the controller broadcasts a message (such as Set time/date) using Address 0, when the target is set to EIA-485 mode.

## 16.5 Packet Structure

Controller-to-target:

Start of Packet	Target Address	Address De-limiter	Instruction Code	Code Qualifier	Optional Arguments	End of Packet
< ASCII code 60  (1 character)	(4 characters)	/ ASCII code 47  (1 character)	(3 characters)	= or ? ASCII code 61 or 63 (1 character)	(n characters)	Carriage Return ASCII code 13  (1 character)

Example: <0135/TFT=1[CR]

Target-to-controller:

Start of Packet	Target Address	Address De-limiter	Instruction Code	Code Qualifier	Optional Arguments	End of Packet
> ASCII code 62  (1 character)	(4 characters)	/ ASCII code 47  (1 character)	(3 characters)	=, ?, !, or * ASCII code 61, 63, 33 or 42 (1 character)	(From 0 to n characters)	Carriage Return, Line Feed ASCII code 13,10 (2 characters)

Example: >0654/RSW=32[CR][LF]

Each of the components of the packet is now explained.

### 16.5.1 Start Of Packet

Controller to Target: This is the character '<' (ASCII code 60)

Target to Controller: This is the character '>' (ASCII code 62)

Because this is used to provide a reliable indication of the start of packet, these two characters may not appear anywhere else within the body of the message.

### 16.5.2 Address

Up to 9,999 devices can be uniquely addressed. In EIA-232 applications this value is set to 0. In EIA-485 applications, the permissible range of values is 1 to 9999. It is programmed into a target unit using the front panel keypad.

Important note: The controller sends a packet with the address of a target - the destination of the packet. When the target responds, the address used is the same address, to indicate to the controller the source of the packet. The controller does not have its own address.

### 16.5.3 Instruction Code

This is a three-character alphabetic sequence that identifies the subject of the message. Wherever possible, the instruction codes have been chosen to have some significance. For example TFQ for transmit frequency, RMD for receive modulation type, etc. This aids in the readability of the message, should it be displayed in its raw ASCII form. Only upper case alphabetic characters may be used (A-Z, ASCII codes 65 - 90).

### 16.5.4 Instruction Code Qualifier

This is a single character that further qualifies the preceding instruction code.

Code Qualifiers obey the following rules:

- 1) From Controller to Target, the only permitted values are:
  - = (ASCII code 61)
  - ? (ASCII code 63)

They have these meanings:

The '=' code (controller to target) is used as the assignment operator, and is used to indicate that the parameter defined by the preceding byte should be set to the value of the argument(s) which follow it.

For example, in a message from controller to target, TFQ=070.0000 would mean 'set the transmit frequency to 70 MHz'

The '?' code (controller to target) is used as the query operator, and is used to indicate that the target should return the current value of the parameter defined by the preceding byte.

For example, in a message from controller to target, TFQ? would mean 'return the current value of the transmit frequency'

- 2) From Target to Controller, the only permitted values are:
  - = (ASCII code 61)
  - ? (ASCII code 63)
  - ! (ASCII code 33)
  - \* (ASCII code 42)
  - # (ASCII code 35)
  - ~ (ASCII Code 126)

They have these meanings:

The '=' code (target to controller) is used in two ways:

First, if the controller has sent a query code to a target (for example TFQ?, meaning 'what's the Transmit frequency?'), the target would respond with TFQ=xxx.xxxx, where xxx.xxxx represents the frequency in question.



Second, if the controller sends an instruction to set a parameter to a particular value, then, providing the value sent in the argument is valid, the target will acknowledge the message by replying with TFQ= (with no message arguments).

The ? code (target to controller) is only used as follows:

If the controller sends an instruction to set a parameter to a particular value, then, if the value sent in the argument is not valid, the target will acknowledge the message by replying (for example) with TFQ? (with no message arguments). This indicates that there was an error in the message sent by the controller.

The \* code (target to controller) is only used as follows:

If the controller sends an instruction to set a parameter to a particular value, then, if the value sent in the argument is valid, BUT the modem will not permit that particular parameter to be changed at that time, the target will acknowledge the message by replying (for example) with TFQ\* (with no message arguments).

The ! code (target to controller) is only used as follows:

If the controller sends an instruction code which the target does not recognize, the target will acknowledge the message by echoing the invalid instruction, followed by the ! character with. Example: XYZ!

The # code (target to controller) is only used as follows:

If the controller sends a correctly formatted command, BUT the modem is not in remote mode, it will not allow reconfiguration, and will respond with TFQ#.

The ~ code (target to controller) is only used as follows:

If a message was sent via a local modem to a distant end device or ODU, the message was transmitted transparently through the local modem. In the event of the distant-end device not responding, the local modem would generate a response e.g. 0001/RET~, indicating that it had finished waiting for a response and was now ready for further comms.

## 16.5.5 Message Arguments

Arguments are not required for all messages. Arguments are ASCII codes for the characters 0 to 9 (ASCII 48 to 57), A to Z (ASCII 65 to 90), period (ASCII 46), space (ASCII 32), \* (ASCII 42), + (ASCII 43), - (ASCII 45), / (ASCII 47), and comma (ASCII 44).

## 16.5.6 End Of Packet

Controller to Target: This is the 'Carriage Return' character (ASCII code 13)

Target to Controller: This is the two-character sequence 'Carriage Return', 'Line Feed'. (ASCII code 13, and code 10.)

Both indicate the valid termination of a packet.

---

## 16.6 Alphabetical list of Remote Commands

<b>A</b>	ITD?, 16-14	RNS?, 16-30
ADJ?, 16-25	ITS?, 16-39	RRS?, 16-20
APP?, 16-13	ITY?, 16-22	RSI?, 16-20
AUP?, 16-13		RSL?, 16-33
<b>B</b>	<b>L</b>	RSW?, 16-21
BFS?, 16-33	LRS?, 16-34	RTC, 16-22
<b>C</b>	<b>M</b>	RTE?, 16-22
CAE=, 16-32	MGC?, 16-28	RVL?, 16-22
CAS=, 16-31	MGC?n, 16-28	<b>S</b>
CID?, 16-27	MSK?, 16-26	SCP?, 16-24
CLD=, 16-29		SNO?, 16-34
CST=, 16-29	<b>N</b>	SSI?, 16-30
CTD?, 16-26	NUE?, 16-31	SWR?, 16-34
<b>D</b>	NUS?, 16-30	<b>T</b>
DAY?, 16-29	<b>O</b>	TBA?, 16-15
DNI?, 16-38	ODU?, 16-27	TCK?, 16-14
DNI?n, 16-38	<b>P</b>	TCR?, 16-11
DTS?, 16-38	PLI?, 16-14	TDR?, 16-11
DTY?, 16-15	<b>R</b>	TET?, 16-15
<b>E</b>	RBA?, 16-22	TFM?, 16-9
EBA?, 16-21	RBS?, 16-21	TFQ?, 16-4
EBN?, 16-33	RCB=, 16-29	TFT?, 16-10
EFM?, 16-23	RCK?, 16-21	TIM?, 16-29
EFR?, 16-25	RCR?, 16-18	TIP?, 16-16
EID?, 16-36	RDR?, 16-19	TIT?, 16-9
ESA?, 16-23	RDS?, 16-20	TMD?, 16-10
ESC?, 16-24	REB?, 16-14	TMP?, 16-35
<b>F</b>	RED?, 16-34	TPL?, 16-12
FCS?, 16-35	REF?, 16-20	TRS?, 16-12
FLT?, 16-32	RET?, 16-23	TSC?, 16-12
FSW=, 16-39	RFM?, 16-17	TSI?, 16-12
<b>I</b>	RFO?, 16-33	TST?, 16-26
IEP=, 16-32	RFQ?, 16-16	TTA?, 16-15
IRD?, 16-21	RFT?, 16-17	TTC?, 16-15
ISP=, 16-31	RIP?, 16-23	TVL?, 16-14
	RIT?, 16-16	TXO?, 16-13
	RMD?, 16-18	<b>W</b>
	RNE?, 16-32	WRM?, 16-25

Parameter Type	Command (Instruction Code and Qualifier)	Arguments for Command or Response to Query	Description of Arguments	Response to Command	Query (Instruction Code and Qualifier)	Response to Query
<b>Tx Frequency</b>	<b>TFQ=</b>	<b>8 bytes</b>	<b>Command or Query.</b> With hardware revision xx.0: standard frequency range: 52 MHz to 88 MHz, or 104 MHz to 176 MHz. With hardware revision xx.1: extended frequency range: 50 MHz to 90 MHz, or 100 MHz to 180 MHz. (Use HRV? to obtain the hardware revision level)\ Resolution=100Hz. Example: TFQ=072.9872 Note: The CDM600 supports both 70 and 140 MHz bands.	<b>TFQ=</b> <b>TFQ?</b> <b>TFQ*</b> <b>TFQ#</b>	<b>TFQ?</b>	<b>TFQ=xxx.xxxx</b> (see description of arguments)
<b>Tx Interface Type</b>	<b>TIT=</b>	<b>1 byte, value of 0 thru 6</b>	<b>Command or Query.</b> Tx Interface Type, where: 0=RS422 1=V.35 2=RS232 (synchronous) 3=Balanced G.703 4=Unbalanced G.703 5=Audio (Data rate fixed at 64 kbps) (IBS/EDMAC only) 6=LVDS  Example: TIT=1 (selects V.35)	<b>TIT=</b> <b>TIT?</b> <b>TIT*</b> <b>TIT#</b>	<b>TIT?</b>	<b>TIT=x</b> (see description of arguments)
<b>Tx Framing Mode</b>	<b>TFM=</b>	<b>1 byte, value of 0 thru 6</b>	<b>Command or Query.</b> Tx Framing mode, where: 0=Unframed 1=IBS 2=IDR 3=DROP (requires D&I FAST option) 4=EDMAC 5=D&I++ (requires D&I FAST option) (version 1.5.0 or higher) 6=ESC++ (requires version 2.0.1 or higher) Example: TFM=0 (selects Unframed mode)	<b>TFM=</b> <b>TFM?</b> <b>TFM*</b> <b>TFM#</b>	<b>TFM?</b>	<b>TFM=x</b> (see description of arguments)

Priority System = TIT (Highest priority) , TFM, TFT, TMD, TCR, and TDR (Lowest Priority), indicated by shading. Any change to a higher priority parameter can override any of the parameters of lower priority.

**Exception:** Select DROP or D&I++ mode using TFM (Transmit Framing type) which is highest priority

Parameter Type	Command (Instruction Code and Qualifier)	Arguments for Command or Response to Query	Description of Arguments	Response to Command	Query (Instruction Code and Qualifier)	Response to Query
<b>Tx FEC Type</b>	<b>TFT=</b>	<b>1 byte, value of 0 thru 9</b>	<p><b>Command or Query.</b>  <b>Tx FEC coding type, where:</b>            0=None (uncoded, rate 1/1) with differential encoding ON            1=Viterbi            2=Viterbi + Reed-Solomon            3=Sequential            4=Sequential + Reed-Solomon            5=TCM (Trellis Code Modulation) (Forces TCR=3 2/3)            6=TCM + Reed-Solomon (Forces TCR=3 2/3)            7=Turbo (TPC)            8=None (uncoded, rate 1/1) with differential encoding OFF            9=LDPC (Requires TPC/LDPC Codec)</p> <p><b>Example: TFT=1 (which is Viterbi coding)</b></p>	<p><b>TFT=</b>  <b>TFT?</b>  <b>TFT*</b>  <b>TFT#</b></p>	<b>TFT?</b>	<b>TFT=x</b> (see description of arguments)
<b>Tx Modulation Type</b>	<b>TMD=</b>	<b>1 byte, value of 0 thru 5</b>	<p><b>Command or Query.</b>  <b>Tx Modulation type, where:</b>            0=BPSK            1=QPSK            2=QPSK            3=8-PSK            4=16-QAM (Turbo or Viterbi + RS only)            5=8-QAM (LDPC only) (Requires TPC/LDPC Codec and FAST option.)</p> <p>Depending on FEC type, not all of these selections will be valid.</p> <p><b>Example: TMD=2 (which is QPSK)</b></p>	<p><b>TMD=</b>  <b>TMD?</b>  <b>TMD*</b>  <b>TMD#</b></p>	<b>TMD?</b>	<b>TMD=x</b> (see description of arguments)

Parameter Type	Command (Instruction Code and Qualifier)	Arguments for Command or Response to Query	Description of Arguments	Response to Command	Query (Instruction Code and Qualifier)	Response to Query
<b>Tx FEC Code Rate</b>	<b>TCR=</b>	<b>1 byte, value of 0 thru 7</b>	<p><b>Command or Query</b>  <b>Tx Modulation Type, where:</b>  <b>0=Rate 1/2</b>  <b>1=Rate 3/4</b>  <b>2=Rate 7/8</b>  <b>3=Rate 2/3 (8-PSK TCM or LDPC only)</b>  <b>4=Rate 1/1 (Uncoded or No FEC)</b>  <b>5=Rate 21/44 (Turbo Only)</b>  <b>6=Rate 5/16 (Turbo Only)</b>  <b>7=Rate 0.95 (Turbo Only)</b></p> <p>Depending on FEC type, not all of these selections will be valid.</p> <p><b>Example: TCR=1 (which is Rate 3/4)</b></p>	<p><b>TCR=</b>  <b>TCR?</b>  <b>TCR*</b>  <b>TCR#</b></p>	<b>TCR?</b>	<b>TCR=x</b> (see description of arguments)
<b>Tx Data Rate</b>	<b>TDR=</b>	<b>9 bytes</b>	<p><b>Command or Query.</b>  <b>Tx Data rate, in kbps, between 2.4 kbps and 20 Mbps</b>  <b>Resolution=1 bps</b></p> <p><b>Example: TDR=02047.999 (which is 2047.999 kbps)</b></p> <p>For Hardware Version 2.0 or higher, and Firmware 1.3.1 or higher, additional auxiliary G.703 sub-rates are available. These are selected using:  <b>00512.AUX</b>  <b>01024.AUX</b>  <b>02048.AUX</b></p> <p>The connectors used for the Aux rates are IDI/DDO. These Aux rates are not available with Drop &amp; Insert or IDR.</p>	<p><b>TDR=</b>  <b>TDR?</b>  <b>TDR*</b>  <b>TDR#</b></p>	<b>TDR?</b>	<b>TDR=xxxxx.xxx</b> (see description of arguments)

Parameter Type	Command (Instruction Code and Qualifier)	Arguments for Command or Response to Query	Description of Arguments	Response to Command	Query (Instruction Code and Qualifier)	Response to Query
<b>Tx Reed-Solomon Encoding</b>	<b>TRS=</b>	<b>1 byte, value of 0 thru 3</b>	<p>Command or Query.</p> <p>Tx RS encoding</p> <p>0=Normal (based on the Open Network framing mode selected)</p> <p>1=IESS-310 mode, available all framing modes, except EDMAC.</p> <p>2=EF Data legacy standard (225,205) – unframed only</p> <p>3=IBS (126,112) – unframed only</p> <p>Example: TRS=0 (This is a ‘don’t care’ if no RS is selected under FEC Type) Available all framing modes, except EDMAC.</p>	<p>TRS=</p> <p>TRS?</p> <p>TRS*</p> <p>TRS#</p>	TRS?	TRS=x (see description of arguments)
<b>Tx Spectrum Invert</b>	<b>TSI=</b>	<b>1 byte, 0 or 1</b>	<p>Command or Query.</p> <p>Tx Spectrum Invert selection, where:</p> <p>0=Normal</p> <p>1=Tx Spectrum Inverted</p> <p>Example:TSI=0 (which is normal)</p>	<p>TSI=</p> <p>TSI?</p> <p>TSI*</p> <p>TSI#</p>	TSI?	TSI=x (see description of arguments)
<b>Tx Scrambler</b>	<b>TSC=</b>	<b>1 byte, 0 or 1</b>	<p>Command or Query.</p> <p>Tx Scrambler state, where:</p> <p>0=Off</p> <p>1=Normal</p> <p>2=IESS-315 when in Turbo mode</p> <p>2=‘Special’ when uncoded or Viterbi (needs FAST Special opt 1)</p> <p>Example: TSC=1 (Scrambler On)</p>	<p>TSC=</p> <p>TSC?</p> <p>TSC*</p> <p>TSC#</p>	TSC?	TSC=x (see description of arguments)
<b>Tx Power Level</b>	<b>TPL=</b>	<b>4 bytes</b>	<p>Command or Query.</p> <p>Tx Output power level between 0 and -20 dBm (minus sign assumed).</p> <p>Example: TPL=13.4 (Command not valid in AUPC mode)</p>	<p>TPL=</p> <p>TPL?</p> <p>TPL*</p> <p>TPL#</p>	TPL?	TPL=xx.x (see description of arguments)

Parameter Type	Command (Instruction Code and Qualifier)	Arguments for Command or Response to Query	Description of Arguments	Response to Command	Query (Instruction Code and Qualifier)	Response to Query
<b>Tx Carrier State</b>	<b>TXO=</b>	<b>1 byte, value of 0 thru 3</b>	<p>Command or Query.</p> <p>Tx Carrier State, where:</p> <p>0=OFF due to front panel or remote control command</p> <p>1=ON</p> <p>2=RTI (receive/transmit inhibit)</p> <p>3=OFF due to ext H/W Tx Carrier Off command (not a valid argument when used as a command, and not indicated in MGC? response)</p> <p>Example: TXO=1 (Tx Carrier ON)</p>	<p>TXO=</p> <p>TXO?</p> <p>TXO*</p> <p>TXO#</p>	<b>TXO?</b>	<b>TXO=x</b> (see description of arguments)
<b>AUPC Enable</b>	<b>AUP=</b>	<b>1 byte, 0 or 1</b>	<p>Command or Query.</p> <p>AUPC mode enable/disable, where:</p> <p>0=Disabled</p> <p>1=Enabled</p> <p>Example: AUP=1</p> <p>Note: EDMAC or D&amp;I++ or ESC++ framing must be selected for the AUPC feature to be available.</p>	<p>AUP=</p> <p>AUP?</p> <p>AUP*</p> <p>AUP#</p>	<b>AUP?</b>	<b>AUP=x</b> (see description of arguments)
<b>AUPC Parameters</b>	<b>APP=</b>	<b>6 bytes</b>	<p>Command or Query.</p> <p>Defines AUPC operating parameters. Has the form abc.cd, where:</p> <p>a=Defines action on max. power condition. (0=do nothing, 1=generate Tx alarm)</p> <p>b=Defines action on remote demod unlock. (0=go to nominal power, 1=go to max power)</p> <p>c.c=target Eb/No value, for remote demod, from 0.0 to 9.9 dB</p> <p>d =Max increase in Tx Power permitted, from 0.0 to 9.0 dB</p> <p>Example: APP=015.67 (Sets no alarm, max power, 5.6 dB target and 7 dB power increase.</p>	<p>APP=</p> <p>APP?</p> <p>APP*</p> <p>APP#</p>	<b>APP?</b>	<b>APP=abc.cd</b> (see description of arguments)

Parameter Type	Command (Instruction Code and Qualifier)	Arguments for Command or Response to Query	Description of Arguments	Response to Command	Query (Instruction Code and Qualifier)	Response to Query
Remote Eb/No	N/A	4 bytes	<p>Query only. Returns the value of Eb/No of the remote demod. Responds 99.9 = remote demod unlocked. Responds xx.x if EDMAC is disabled. xx.x=02.0 to 16.0</p> <p>Example: REB=12.4 Note: For values &gt; 16.0 dB, the reply will be 16.0</p>	N/A	REB?	REB=xx.x (see description of arguments)
Tx Power Level Increase	N/A	3 bytes	<p>Query only. Returns the increase in Tx power level, in dB (from the nominal setting) due to the action of AUPC. Responds x.x if AUPC is disabled.</p> <p>Example: PLI=2.3</p>	N/A	PLI?	PLI=x.x (see description of arguments)
Tx Clock Source	TCK=	1 byte, value of 0 thru 3	<p>Command or Query. Tx Clock Source, where: 0=Internal 1=Tx Terrestrial 2=Rx Loop-Timed 3=External Clock</p> <p>Example: TCK=0 (selects Internal)</p>	TCK= TCK? TCK* TCK#	TCK?	TCK=x (see description of arguments)
Invert Tx Data	ITD=	1 byte, 0 or 1	<p>Command or Query. Invert Transmit Data 0=Normal 1=Inverted</p> <p>Example: ITD = 1 (selects Inverted TX Data)</p>	ITD= ITD? ITD* ITD#	ITD?	ITD=x (see description of arguments)
Tx Audio Volume Control	TVL=	4 bytes	<p>Command or Query. (Audio/IDR Parameter) Tx Audio Volume control, in the form aabb, where: aa=Tx 1 volume control in dB, values defined below. bb=Tx 2 volume control in dB, values defined below. Valid values: -6, -4, -2, +0, +2, +4, +6, +8</p> <p>Example: TVL= -2+4 (sets Tx 1 to 2 dB and Tx 2 to +4 dB)</p>	TVL= TVL? TVL* TVL#	TVL?	TVL=aabb (see description of arguments)



Parameter Type	Command (Instruction Code and Qualifier)	Arguments for Command or Response to Query	Description of Arguments	Response to Command	Query (Instruction Code and Qualifier)	Response to Query
Transmit Terrestrial Alarm Mask	TTA=	1 byte, 0 or 1	Command or Query. (DROP mode parameter) Transmit terrestrial Alarm Mask conditions, where: 0=Alarm is active (unmasked). 1=Alarm is masked.  Example: TTA=1 (masks an alarm).	TTA= TTA? TTA* TTA#	TTA?	TTA=x (see description of arguments)
Drop Type	DTY=	1 byte, value of 0 thru 3	Command or Query. (DROP/D&I++ mode parameter) Drop Type where: 0=T1-D4 1=T1-ESF 2=E1-CCS 3=E1-CAS	DTY= DTY? DTY* DTY#	DTY?	DTY=x
Tx Ternary Code	TTC=	1 byte, value of 0 thru 3	Command or Query. (G.703 Parameter) Tx Ternary Code, where: 0=AMI 1=B8ZS 2=B6ZS 3=HDB3  Example: TTC=1 (selects B8ZS)	TTC= TTC? TTC* TTC#	TTC?	TTC=x (see description of arguments)
Transmit Backward Alarms Enable	TBA=	4 bytes, each a value of 0 thru 2	Command or Query. (IDR Parameter)  Enable Transmit backward alarm enable: 0=Disable 1=Enable Internal (S/W) 2=Enable External (H/W)  Example: TBA=0120	TBA= TBA? TBA* TBA#	TBA?	TBA=xxxx  Position indicates backward alarm numbers: 1234
Transmit ESC Type	TET=	1 byte, 0 or 1	Command or Query. (IDR Parameter) Sets or queries IDR ESC Type, where: 0=64k data channel 1=2 Audio channels	TET= TET? TET* TET#	TET?	TET=x

Parameter Type	Command (Instruction Code and Qualifier)	Arguments for Command or Response to Query	Description of Arguments	Response to Command	Query (Instruction Code and Qualifier)	Response to Query
<b>Tx IF Impedance</b>	<b>TIP=</b>	<b>1 byte, value of 5 or 7</b>	<p>Command or Query.</p> <p>Tx IF Impedance, where:  <b>5=50Ω</b>  <b>7=75Ω</b></p> <p>Both Tx and Rx sides will change with this selection.                      Example: TIP=5 (50Ω)</p>	<b>TIP=</b> <b>TIP?</b> <b>TIP*</b> <b>TIP#</b>	<b>TIP?</b>	<b>TIP=x</b> (see description of arguments)
<b>Rx Frequency</b>	<b>RFQ=</b>	<b>8 bytes</b>	<p>Command or Query.</p> <p>With hardware revision xx.0: standard frequency range:  <b>52 MHz to 88 MHz, or 104 MHz to 176 MHz.</b>                      With hardware revision xx.1: extended frequency range:  <b>50 MHz to 90 MHz, or 100 MHz to 180 MHz.</b></p> <p>Use HRV? to obtain the hardware revision level.</p> <p>Resolution=100Hz.</p> <p>Example: RFQ=072.9872</p> <p>Note: The CDM600 supports both 70 and 140 MHz bands.</p>	<b>RFQ=</b> <b>RFQ?</b> <b>RFQ*</b> <b>RFQ#</b>	<b>RFQ?</b>	<b>RFQ=xxx.xxxx</b> (see description of arguments)
<b>Rx Interface Type</b>	<b>RIT=</b>	<b>1 byte, value of 0 thru 6</b>	<p>Command or Query.</p> <p>Rx Interface Type, where:  <b>0=RS422</b>  <b>1=V.35</b>  <b>2=RS232 (synchronous)</b>  <b>3=Balanced G.703</b>  <b>4=Unbalanced G.703</b>  <b>5=Audio (Data rate is fixed at 64 kbps) (IBS/EDMAC only)</b>  <b>6=LVDS</b></p> <p>Example: RIT=1 (selects V.35)</p>	<b>RIT=</b> <b>RIT?</b> <b>RIT*</b> <b>RIT#</b>	<b>RIT?</b>	<b>RIT=x</b> (see description of arguments)

Parameter Type	Command (Instruction Code and Qualifier)	Arguments for Command or Response to Query	Description of Arguments	Response to Command	Query (Instruction Code and Qualifier)	Response to Query
Rx Framing Mode	RFM=	1 byte, value of 0 thru 6	<p>Command or Query. Rx Framing mode, where:</p> <ul style="list-style-type: none"> <li>0=Unframed</li> <li>1=IBS</li> <li>2=IDR</li> <li>3=INSERT (requires D&amp;I FAST option)</li> <li>4=EDMAC</li> <li>5=D&amp;I++ (requires D&amp;I FAST option) (version 1.5.0 or higher)</li> <li>6=ESC++ (requires version 2.0.1 or higher)</li> </ul> <p>Example: RFM=0 (selects Unframed mode)</p>	<p>RFM= RFM? RFM* RFM#</p>	RFM?	RFM=x (see description of arguments)
Rx FEC Type	RFT=	1 byte, value of 0 thru 9	<p>Command or Query. Rx FEC Type, where:</p> <ul style="list-style-type: none"> <li>0=None (uncoded) with differential encoding ON</li> <li>1=Viterbi</li> <li>2=Viterbi + Reed-Solomon</li> <li>3=Sequential</li> <li>4=Sequential + Reed-Solomon</li> <li>5=TCM (Trellis Code Modulation)</li> <li>6=TCM + Reed-Solomon</li> <li>7=Turbo (TPC)</li> <li>8=None (uncoded) with differential encoding OFF</li> <li>9=LDPC (Requires TPC/LDPC Codec)</li> </ul> <p>Example: RFT=1 (which is Viterbi only)</p>	<p>RFT= RFT? RFT* RFT#</p>	RFT?	RFT=x (see description of arguments)

Parameter Type	Command (Instruction Code and Qualifier)	Arguments for Command or Response to Query	Description of Arguments	Response to Command	Query (Instruction Code and Qualifier)	Response to Query
Rx Demod Type	RMD=	1 byte, value of 0 thru 5	<p>Command or Query. Rx Demodulation, where: 0=BPSK 1=QPSK 2=QPSK 3=8-PSK 4=16-QAM (Turbo or Viterbi + RS only) 5=8-QAM (LDPC only) (Requires TPC/LDPC Codec and FAST option)</p> <p>Depending on FEC type, not all of these selections will be valid.</p> <p>All other codes are invalid. Example: RMD=2 (selects OQPSK)</p>	RMD= RMD? RMD* RMD#	RMD?	RMD=x (see description of arguments)
Rx FEC Code Rate	RCR=	1 byte, value of 0 thru 7	<p>Command or Query. Rx FEC Code Rate, where: 0=Rate 1/2 1=Rate 3/4 2=Rate 7/8 3=Rate 2/3 (8-PSK TCM or LDPC only) 4=Rate 1/1 (Uncoded or No FEC) 5=Rate 21/44 (Turbo Only) 6=Rate 5/16 (Turbo Only) 7=Rate 0.95 (Turbo Only)</p> <p>Depending on FEC type, not all of these selections will be valid.</p> <p>Example: RCR=1 (selects Rate 3/4)</p>	RCR= RCR? RCR* RCR#	RCR?	RCR=x (see description of arguments)

Parameter Type	Command (Instruction Code and Qualifier)	Arguments for Command or Response to Query	Description of Arguments	Response to Command	Query (Instruction Code and Qualifier)	Response to Query
Rx Data Rate	RDR=	9 bytes	<p>Command or Query. Rx Data Rate, in kbps, between 2.4 kbps to 20 Mbps. Resolution=1 bps</p> <p>Example: RDR=02047.999.</p> <p>For Hardware Version 2.0 or higher, and Firmware 1.3.1 or higher, additional auxiliary G.703 sub-rates are available. These are selected using: 00512.AUX 01024.AUX 02048.AUX</p> <p>The connectors used for the Aux rates are IDI/DDO. These Aux rates are not available with D&amp;I or IDR.</p>	RDR= RDR? RDR* RDR#	RDR?	RDR=xxxxx.xxx (see description of arguments)

Priority System = RIT (Highest priority) , RFM, RFT, RMD, RCR, and RDR (Lowest Priority), indicated by shading. Any change to a higher priority parameter can override any of the parameters of lower priority.

Exception: Select INSERT or D&I++ mode using RFM (Receive Framing type) which is highest priority

Parameter Type	Command (Instruction Code and Qualifier)	Arguments for Command or Response to Query	Description of Arguments	Response to Command	Query (Instruction Code and Qualifier)	Response to Query
External Clock	REF=	10 bytes	<p>Command or Query.</p> <p>x=External Baseband Clock between 2.4 kHz and 20 MHz.</p> <p>y=U for Unbalanced, B for Balanced.</p> <p>Example: REF =10000.000U (Selects 10M, Unbalanced)</p>	REF= REF? REF* REF#	REF?	REF=xxxxx.xxy
Rx Reed-Solomon Decoding	RRS=	1 byte, value of 0 thru 3	<p>Command or Query.</p> <p>Rx RS decoding, where:</p> <p>0=Normal (based on the Open Network framing mode selected)</p> <p>1=IESS-310 mode, available all framing modes, except EDMAC.</p> <p>2=EF Data legacy standard (225,205) – unframed only</p> <p>3=IBS (126,112) – unframed only</p> <p>Note: Available in all framing modes, except EDMAC. (This is a 'don't care' if no RS is selected in FEC type)</p> <p>Example: RRS=0 (selects Normal)</p>	RRS= RRS? RRS* RRS#	RRS?	RRS=x (see description of arguments)
Rx Spectrum Invert	RSI=	1 byte, 0 or 1	<p>Command or Query.</p> <p>Rx Spectrum Invert, where:</p> <p>0=Normal</p> <p>1=Rx Spectrum Invert</p> <p>Example: RSI=0 (selects Normal)</p>	RSI= RSI? RSI* RSI#	RSI?	RSI=x (see description of arguments)
Rx Descrambler	RDS=	1 byte, 0 or 1	<p>Command or Query.</p> <p>Rx Descrambler state, where:</p> <p>0=Off</p> <p>1=Normal</p> <p>2=IESS-315 when in Turbo mode</p> <p>2=Special when uncoded or Viterbi, needs FAST Special Opt 1.</p> <p>Example: RDS=1 (Scrambler On)</p>	RDS= RDS? RDS* RDS#	RDS?	RDS=x (see description of arguments)

Parameter Type	Command (Instruction Code and Qualifier)	Arguments for Command or Response to Query	Description of Arguments	Response to Command	Query (Instruction Code and Qualifier)	Response to Query
Invert Rx Data	IRD=	1 byte, 0 or 1	<p>Command or Query. Invert Receive Data 0=Normal 1=Inverted</p> <p>Example: IRD = 1 (selects Inverted RX Data)</p>	IRD= IRD? IRD* IRD#	IRD?	IRD=x (see description of arguments)
Rx Demod Acquisition Sweep Width	RSW=	2 bytes	<p>Command or Query. Rx <math>\pm</math> acquisition sweep range of demodulator, in kHz, ranging from <math>\pm 1</math> to <math>\pm 32</math> kHz</p> <p>Example: RSW=09 (selects <math>\pm 9</math> kHz)</p>	RSW= RSW? RSW* RSW#	RSW?	RSW=xx (see description of arguments)
Rx Clock Source	RCK=	1 byte, value of 0 thru 3	<p>Command or Query. Rx Clock Source, where: 0=Rx Satellite 1=Tx-Terrestrial 2=External Clock Source 3=INSERT (command valid only when Rx framing is Insert or D&amp;I++ and interface is G.703 or set for D&amp;I loop.</p> <p>Example: RCK=1 (selects Tx-Terrestrial)</p>	RCK= RCK? RCK* RCK#	RCK?	RCK=x (see description of arguments)
Eb/No Alarm Point	EBA=	4 bytes	<p>Command or Query. Eb/No alarm point in dB, with a range between 0.1 and 16 dB. Resolution=0.1 dB</p> <p>Example: EBA=12.3</p>	EBA= EBA? EBA* EBA#	EBA?	EBA=xx.x (see description of arguments)
Rx Buffer Size	RBS=	5 bytes	<p>Command or Query. Rx Buffer Size, 16 to 32768 bytes, in 2-byte steps, unless other limitations apply. (See 6.3.1.5)</p> <p>Example: RBS=08192 (selects 8192 bytes)</p>	RBS= RBS? RBS* RBS#	RBS?	RBS=xxxxx (see description of arguments)

Parameter Type	Command (Instruction Code and Qualifier)	Arguments for Command or Response to Query	Description of Arguments	Response to Command	Query (Instruction Code and Qualifier)	Response to Query
Rx Audio Volume Control	RVL=	4 bytes	<p>Command or Query. (Audio/IDR Parameters) Rx Audio Volume control, in the form aabb, where: aa=Rx 1 volume control in dB, values defined below. bb=Rx 2 volume control in dB, values defined below. Valid values: -6, -4, -2, +0, +2, +4, +6, +8</p> <p>Example: RVL= -2+4 (sets Rx 1 to -2 dB and Rx 2 to +4 dB)</p>	RVL= RVL? RVL* RVL#	RVL?	RVL=aabb (see description of arguments)
Receive Terrestrial Alarm Enable	RTE=	1 byte, 0 or 1	<p>Command or Query. (INSERT mode parameter) Receive Terrestrial Alarm Enable conditions, where: 0=Disables the alarm 1=Enables the alarm.</p> <p>Example: RTE=0 (selects Disable the alarm).</p>	RTE= RTE? RTE* RTE#	RTE?	RTE=x (see description of arguments)
Insert Type	ITY=	1 byte, value of 0 thru 3	<p>Command or Query. (INSERT/D&amp;I++ mode parameter) Insert Type, where: 0=T1-D4 1=T1-ESF 2=E1-CCS 3=E1-CAS</p>	ITY= ITY? ITY* ITY#	ITY?	ITY=x
Rx Ternary Code	RTC=	1 byte, value of 0 thru 3	<p>Command or Query. (G.703 Parameter) Rx Ternary Code, where: 0=AMI 1=B8ZS 2=B6ZS 3=HDB3</p> <p>Example: RTC=1 (selects B8ZS)</p>	RTC= RTC? RTC* RTC#	RTC?	RTC=x (see description of arguments)
Receive Backward Alarms Enable	RBA=	4 bytes, each a value of 0 or 1	<p>Command or Query. (IDR Parameter) Enable Receive backward alarm enable: 0=Disable 1=External trigger Enable</p> <p>Example: RBA=0101</p>	RBA= RBA? RBA* RBA#	RBA?	RBA=xxxx



Parameter Type	Command (Instruction Code and Qualifier)	Arguments for Command or Response to Query	Description of Arguments	Response to Command	Query (Instruction Code and Qualifier)	Response to Query
Receive ESC Type	RET=	1 byte, 0 or 1	Command or Query. (IDR Parameter) Sets or queries IDR ESC Type, where: 0=64k data channel 1=2 Audio channels	RET= RET? RET* RET#	RET?	RET=x
Rx IF Impedance	RIP=	1 byte, value of 5 or 7	Command or Query. Rx IF Impedance, where: 5=50Ω 7=75Ω  Both Tx and Rx sides will change with this selection. Example: RIP=5 (50Ω)	RIP= RIP? RIP* RIP#	RIP?	RIP=x (see description of arguments)
EDMAC Framing Mode	EFM=	1 byte, 0 or 1	Command or Query EDMAC mode, where: 0=EDMAC OFF (Idle Mode) 1=EDMAC ON (Master Mode) 2=EDMAC ON (Slave Mode, Query Only)  Example: EFM=1 (EDMAC Enabled as Master)	EFM= EFM? EFM* EFM#	EFM?	EFM=x (see description of arguments)
EDMAC Slave Address Range	ESA=	4 bytes	Command or Query  EDMAC Slave Address Range - sets the range of addresses of distant-end units (modems or transceivers) that this unit, as the Master, will forward messages for. Only values which are integer multiples of ten are permitted. (0010, 0020, 0030, 0040 etc.)  Example: ESA=0090  This command is only valid for an EDMAC master. When used as a Query, it may be sent to an EDMAC slave, which will respond with the appropriate address.	ESA= ESA? ESA* ESA#	ESA?	ESA=xxxx (see description of arguments)

Parameter Type	Command (Instruction Code and Qualifier)	Arguments for Command or Response to Query	Description of Arguments	Response to Command	Query (Instruction Code and Qualifier)	Response to Query
Engineering Service Channel	ESC=	1 byte, 0 or 1	<p>Command or query. (IBS and ESC++ feature) ESC=x</p> <p>Where: x = 0 (Disable the high-rate ESC) x = 1 (Enable the high-rate ESC)</p> <p>IBS ESC may only be enabled when:</p> <ol style="list-style-type: none"> <li>Both Tx and Rx framing modes are set to IBS.</li> <li>Data rate is not 1544 kbps (as spare overhead bits are not available in this mode).</li> <li>IBS high-rate ESC FAST option is enabled.</li> </ol>	ESC= ESC? ESC* ESC#	ESC?	ESC=x (see description of arguments)
ESC Parameters	SCP=	2 bytes, numeric	<p>Command or query. (IBS and ESC++ feature)</p> <p>Allows control of the ESC baud rate and character format, where x is the index for baud rate:</p> <p>0=1200 baud 1=2400 baud 2=4800 baud 3=9600 baud 4=19200 baud 5=38400 baud 6=14400 baud 7=28800 baud</p> <p>and where y is the character format (data bits, parity, stop bits):</p> <p>0=8N1 char format 1=7E2 char format 2=7O2 char format</p> <p>The baud rate may be limited by the data rate. The ESC baud rate breakpoints (determined by data rate) are shown in Chapter 6 and Chapter 13. A response of SCP* will indicate if the data rate will not allow a selected baud rate to operate.</p>	SCP= SCP? SCP* SCP#	SCP?	SCP=xy (see description of arguments)

Parameter Type	Command (Instruction Code and Qualifier)	Arguments for Command or Response to Query	Description of Arguments	Response to Command	Query (Instruction Code and Qualifier)	Response to Query
External Frequency Reference	EFR=	1 byte, value of 0 thru 5	<p>Command or query. (Hi-stab Ref parameter) Requires hardware Rev. 2.0 or greater and High-Stability Frequency Reference module to be installed. 0 = Internal 10MHz (default when module is not installed) 1 = External 1 MHz 2 = External 2 MHz 3 = External 5 MHz 4 = External 10 MHz 5 = External 20 MHz</p> <p>See the EID response for indication that a high-stability module is installed.</p>	EFR= EFR? EFR* EFR#	EFR?	EFR=x (see description of arguments)
Internal 10MHz Reference Adjustment	ADJ=	4 bytes, numeric	<p>Command or query. (Hi-stab Ref parameter) This command provides fine adjustment of the Internal 10MHz Reference on the High-Stability Frequency Reference module.</p> <p>Format is sddd, where: s = sign (+ or -) ddd = value, 0-999</p> <p>If High-Stability module is not installed, response to query is ADJ*.</p>	ADJ= ADJ? ADJ* ADJ#	ADJ?	ADJ=sddd (see description of arguments)
Warm-up Delay	WRM=	1 byte, 0 or 1	<p>Command or query. (Hi-stab Ref parameter)</p> <p>0 = Delay off (instant on) 1 = Warm-up Delay on</p> <p>If Hi-Stability module is not installed, response to query is WRM*.</p>	WRM= WRM? WRM* WRM#	WRM?	WRM=x (see description of arguments)

Parameter Type	Command (Instruction Code and Qualifier)	Arguments for Command or Response to Query	Description of Arguments	Response to Command	Query (Instruction Code and Qualifier)	Response to Query
Countdown of Warm-up Delay remaining	CTD=	3 bytes, numeric	<p>Command or query. (Hi-stab Ref parameter) Requires High-Stability Frequency Reference module to be installed.</p> <p>xxx = countdown of the number of seconds remaining of the Warm-up time.</p> <p>As a command, the only permitted format is CTD=000, which abandons the delay.</p> <p>If Hi-Stability module is not installed, response to query is CTD*.</p>	CTD= CTD? CTD* CTD#	CTD?	CTD=xxx (see description of arguments)
Unit Test Mode	TST=	1 byte, value of 0 thru 6	<p>Command or Query. CDM-600 Test Mode, where: 0=Normal Mode (no test) 1=Tx CW 2=Tx Alternating 1,0 Pattern 3=IF Loopback 4=RF Loopback 5=Digital Loopback 6=I/O Loopback</p> <p>Example: TST=3 (IF Loopback)</p>	TST= TST? TST* TST#	TST?	TST=x (see description of arguments)
Unit Alarm Mask	MSK=	6 bytes	<p>Command or Query. Alarm mask conditions, in form abcdef, where: a=Tx AIS (0 = unmasked, 1 = masked) b=Rx AIS (0 = unmasked, 1 = masked) c=bufferslip Alarm (0 = unmasked, 1 = masked) d=spare e=Rx AGC Alarm (0 = unmasked, 1 = masked) f=Eb/No Alarm (0 = unmasked, 1 = masked)</p> <p>Example: MSK=010110</p>	MSK= MSK? MSK* MSK#	MSK?	MSK=abcdef (see description of arguments)

Parameter Type	Command (Instruction Code and Qualifier)	Arguments for Command or Response to Query	Description of Arguments	Response to Command	Query (Instruction Code and Qualifier)	Response to Query
<b>Circuit ID String</b>	<b>CID=</b>	<b>40 bytes</b>	<b>Command or Query</b> Sets or queries the user-defined Circuit ID string, which is a fixed length of 40 characters. Valid characters include: Space ( ) * + - , . / 0 9 and A thru Z	<b>CID=</b> <b>CID?</b> <b>CID*</b> <b>CID#</b>	<b>CID?</b>	<b>CID=x</b> (see description of arguments)
<b>Outdoor Unit Comms enable</b>	<b>ODU=</b>	<b>1 byte, 0 or 1</b>	<b>Command or Query.</b> Enables or disables communications, via the FSK link, with a Comtech EF Data transceiver (ODU), where: 0=Disabled 1=Enabled  <b>Example: ODU=0 (selects Disabled)</b>	<b>ODU=</b> <b>ODU?</b> <b>ODU*</b> <b>ODU#</b>	<b>ODU?</b>	<b>ODU=x</b> (see description of arguments)

Parameter Type	Command (Instruction Code and Qualifier)	Arguments for Command or Response to Query	Description of Arguments	Response to Command	Query (Instruction Code and Qualifier)	Response to Query	
<b>Global Configuration</b>	<b>MGC=</b>	<b>118 bytes, with numerical entries, fixed values and delimiters</b>	<p>Command or Query.Global Configuration of CDM600, in the form:</p> <p>FFF.FFFF=Tx Frequency            DDDDD.DDD=TX Data Rate            G=Tx FEC Type            Y=Tx Reed-Solomon Type            R=Tx FEC Rate            M=Tx Modulation Type            V=Tx Spectrum Inversion            S=Tx Scrambler State            PP.P Tx Power Level            B=AUPC Enable            aaa.aa=AUPC Parameter Setup            C=Tx Clock Source            X=Tx Carrier State            I=Tx Interface Type            K=Tx Ternary Code            N=Tx Framing Mode            Z=Tx IF Impedance            fff.fff=Rx Frequency            ddddd.ddd=Rx Data Rate            g=Rx FEC Type            y=Rx Reed-Solomon Type            r=Rx FEC Rate            m=Rx Modulation Type            v=Rx Spectrum Inversion            s=Rx Scrambler State            ww=Rx Sweep Width            c=Rx Clock Source            tt.t=Eb/No Alarm Point            bbbbb=Rx Buffer Size            i=Rx Interface Type            k=Rx Ternary Code            n=Rx Framing Mode            z=Rx IF Impedance            O=EDMAC or ESC Mode            EEEE=EDMAC Address or ESC Para            T=Unit Test Mode            AAAAA=Unit Alarm Mask            W=Hi-Stab module: REF Setting            e=Statistics Sampling Interval            L=Rx Terrestrial Alarm Enable            Q=Tx Terrestrial Alarm Enable            U=ODU Common Enable            HHHH= Tx Backward Alarm            hhhh= Rx Backward Alarm            JJJJ=Tx Audio Volume            jjjj= Rx Audio Volume            k=Drop Type, k=Insert Type            p=Tx ESC Type, q=Rx ESC Type            u=Invert Tx Data            x= Invert Rx Data</p>	<p>FFF.FFFFDDDD.DDDGYRMVSP.PBaaa.aa            CXIKNZfff.ffffdddd.dddgyrmvswctt.tbbbb            biknzOEEEEAAAAAAWeLQUHHHHhhhhJJ            JJJJJkKpqx, where:</p> <p>same as TFQ            same as TDR            same as TFT            same as TRS            same as TCR            same as TMD            same as TSI            same as TSC            same as TPL            same as AUP            same as APP            same as TCK            same as TXO            same as TIT            same as TTC            same as TFM            same as TIP            same as RFQ            same as RDR            same as RFT            same as RRS            same as RCR            same as RMD            same as RSI            same as RDS            same as RSW            same as RCK            same as same as EBA            same as RBS            same as RIT            same as RTC            same as RFM            same as RIP            same as EFM (or ESC, when in IBS mode)            same as ESA (or SCP, in IBS mode-xy00)            same as TST (read only)            same as MSK            same as EFR            same as SSI            same as RTE            same as TTA            same as ODU            same as TBA            same as RBA            same as TVL            same as RVL            same as DTY, ITY            same as TET, RET            same as ITD            same as IRD</p>	<p><b>MGC=</b>  <b>MGC?</b>  <b>MGC*</b>  <b>MGC#</b></p>	<p><b>MGC?</b></p> <p><b>MGC?n</b></p>	<p><b>MGC=FFF.FFFFDDDD            DD.DDDGYRMVSP.P            PBaaa.aaCXIKNZfff.f            fffdddd.dddgyrmvs            wctt.tbbbbiknzOE            EEEAAAAAAWeLQ            UHHHHhhhhJJJJjjj            Kkpqx</b>            (see description of arguments)</p> <p><b>Returns current configuration</b></p> <p><b>Where n = 0 to 9.            Returns the MGC portion of 1 of 10 stored configurations</b></p>

Parameter Type	Command (Instruction Code and Qualifier)	Arguments for Command or Response to Query	Description of Arguments	Response to Command	Query (Instruction Code and Qualifier)	Response to Query
Configuration Save	CST=	1 byte, value of 0 thru 9	<p>Command only.</p> <p>Command causes the CDM600 to store the current modem configuration in Configuration Memory location defined by the one-byte argument (0 to 9).</p> <p>Example: CST=4 (store the current configuration in location 4)</p>	<p>CST=</p> <p>CST?</p> <p>CST*</p> <p>CST#</p>	N/A	N/A
Configuration Load	CLD=	1 byte, value of 0 thru 9	<p>Command only.</p> <p>Causes the CDM600 to retrieve a previously stored modem configuration from Configuration Memory location defined by the one-byte argument (0 to 9).</p> <p>Example: CLD=4 (load modem configuration from location 4 to be the active configuration)</p>	<p>CLD=</p> <p>CLD?</p> <p>CLD*</p> <p>CLD#</p>	N/A	N/A
ReCenter Buffer	RCB=	None	<p>Command only.</p> <p>Forces the software to recenter the receive Plesiochronous/Doppler buffer.</p> <p>Note: This command takes no arguments.</p> <p>Example: RCB=</p>	<p>RCB=</p> <p>RCB?</p> <p>RCB*</p> <p>RCB#</p>	N/A	N/A
RTC Date	DAY=	6 bytes	<p>Command or Query.</p> <p>A date in the form ddmmyy (international format), where dd = day of the month (01 to 31), mm = month (01 to 12) yy = year (00 to 99)</p> <p>Example: DAY=240457 (April 24, 2057)</p>	<p>DAY=</p> <p>DAY?</p> <p>DAY*</p> <p>DAY#</p>	DAY?	DAY=ddmmyy (see description of arguments)
RTC Time	TIM=	6 bytes	<p>Command or Query.</p> <p>A time in the form hhmmss, indicating the time from midnight, where: hh = hours (00 to 23) mm = minutes (00 to 59) ss = seconds (00 to 59)</p> <p>Example: TIM=231259 (23 hours:12 minutes:59 seconds)</p>	<p>TIM=</p> <p>TIM?</p> <p>TIM*</p> <p>TIM#</p>	TIM?	TIM=hhmmss (see description of arguments)

Parameter Type	Command (Instruction Code and Qualifier)	Arguments for Command or Response to Query	Description of Arguments	Response to Command	Query (Instruction Code and Qualifier)	Response to Query
Statistics Sample Interval	SSI=	1 byte, numerical	<p>Command or Query. Used to set the sample interval for the Statistics Logging Function SSI=x, where x= 0 to 9 in 10 minute steps.</p> <p>Note: Setting this parameter to 0 disables the statistics logging function.</p> <p>Example: SSI=3 means 30 minutes</p>	SSI= SSI? SSI* SSI#	SSI?	SSI=x (see description for details of argument)
Number of Unread stored Statistics	N/A	3 bytes	<p>Query only. Unit returns the number of stored Statistics, which remain Unread, in the form xxx (0-199).</p> <p>Note: This means unread over the remote control.</p> <p>Example: NUS=187</p>	N/A	NUS?	NUS=xxx (see description of arguments)
Retrieve next 5 unread Stored Statistics	N/A	135 bytes	<p>Query only. Unit returns the oldest 5 Stored Statistics, which have not yet been read over the remote control. Reply format: [CR]sub-body[CR]sub-body[CR]sub-body[CR]sub-body[CR]sub-body, where Sub-body=AA.ABB.BC.CD.Dddmmyyhmmss, AA.A=Minimum Eb/No during sample period. BB.B=Average Eb/No during sample period. C.C=Max. Tx Power Level Increase during sample period. D.D=Average Tx Power Level Increase during sample period. ddmmyyhmmss = date/time stamp.</p> <p>If there are no new events, the unit replies with RNS*. If there are less than 5 statistics to be retrieved, the remaining positions are padded with zeros.</p>	N/A	RNS?	<p>RNS=[CR]AA.ABB.BC.CD.Dddmmyyhmmss[CR]AA.ABB.BC.CD.Dddmmyyhmmss[CR]AA.ABB.BC.CD.Dddmmyyhmmss[CR]AA.ABB.BC.CD.Dddmmyyhmmss[CR]AA.ABB.BC.CD.Dddmmyyhmmss[CR]AA.ABB.BC.CD.Dddmmyyhmmss</p> <p>(see description for details of arguments)</p>



Parameter Type	Command (Instruction Code and Qualifier)	Arguments for Command or Response to Query	Description of Arguments	Response to Command	Query (Instruction Code and Qualifier)	Response to Query
<b>Clear All Stored Statistics</b>	<b>CAS=</b>	<b>None</b>	<b>Command only.</b> <b>Forces the software to clear the software statistics log.</b>  <b>Example: CAS=</b> <b>Note: This command takes no arguments.</b>	<b>CAS=</b> <b>CAS?</b> <b>CAS*</b> <b>CAS#</b>	<b>N/A</b>	<b>N/A</b>
<b>Initialize Statistics Pointer</b>	<b>ISP=</b>	<b>None</b>	<b>Command only.</b> <b>Resets internal pointer to allow RNS? queries to start at the beginning of the statistics log.</b>	<b>ISP=</b> <b>ISP#</b>	<b>N/A</b>	<b>N/A</b>
<b>Number of Unread stored Events</b>	<b>N/A</b>	<b>3 bytes</b>	<b>Query only.</b> <b>Unit returns the Number of stored Events, which remain Unread, in the form xxx (0-199).</b> <b>Note: This means unread over the remote control.</b>  <b>Example: NUE=126</b>	<b>N/A</b>	<b>NUE?</b>	<b>NUE=xxx</b> <b>(see description of arguments)</b>

Parameter Type	Command (Instruction Code and Qualifier)	Arguments for Command or Response to Query	Description of Arguments	Response to Command	Query (Instruction Code and Qualifier)	Response to Query
Retrieve next 5 unread Stored Events	N/A	80 bytes	<p><b>Query only.</b> Unit returns the oldest 5 Stored Events which have not yet been read over the remote control. Reply format: [CR]sub-body[CR]sub-body[CR]sub-body[CR]sub-body[CR]sub-body, where Sub-body=ABCddmmyyhhmmss, A is the fault/clear indicator: F=Fault C=Clear I=Info B is the fault type where: 1=Unit 2=Rx Traffic 3=Tx Traffic 4=Power on/off, or log cleared 5=Open Network C is Fault Code number, as in FLT? or Info Code, which is: 0=Power Off 1=Power On 2=Log Cleared 3=Global Config Change 4=Redundancy Config Change ddmmyyhhmmss = date/time stamp.</p> <p>If there are less than 5 events to be retrieved, the remaining positions are padded with zeros. If there are no new events, the response is RNE*.</p>	N/A	RNE?	<p>RNE=[CR]ABCddmmyyhhmmss[CR]ABCddmmyyhhmmss[CR]ABCddmmyyhhmmss[CR]ABCddmmyyhhmmss[CR]ABCddmmyyhhmmss</p> <p>(see description for details of arguments)</p>
Clear All Stored Events	CAE=	None	<p><b>Command only.</b> Forces the software to clear the software events log.</p> <p>Example: CAE=</p> <p>Note: This command takes no arguments</p>	CAE= CAE? CAE* CAE#	N/A	N/A

Parameter Type	Command (Instruction Code and Qualifier)	Arguments for Command or Response to Query	Description of Arguments	Response to Command	Query (Instruction Code and Qualifier)	Response to Query
Initialize Events Pointer	IEP=	None	Command only. Resets internal pointer to allow RNE? queries to start at the beginning of the stored events log.	IEP= IEP#	N/A	N/A
Rx Eb/No	N/A	4 bytes	Query only. Unit returns the value of Eb/No, between 0 to 16 dB. Resolution 0.1 dB. Returns 99.9 if demod is unlocked. Returns +016 for values greater than 16.0 dB.  Example EBN=12.3 (which is Eb/No = 12.3 dB)	N/A	EBN?	EBN=xxxx (see description of arguments)
Rx Signal Level	N/A	5 bytes	Query Only. Unit returns the value of the Rx signal level, in dBm, between -20 and -60 dBm. If >-20dBm, returns RSL=GT-20 (GT means 'greater than') If in the range of -20 to -60dBm, returns RSL===-xx If <-60 dBm, returns RSL=LT-60 (LT means 'less than')  Example: RSL=== -45 (which is -45 dBm)	N/A	RSL?	RSL=xxxxx (see description of arguments)
Rx Frequency Offset	N/A	5 bytes	Query only. Unit returns the value of the measured frequency offset of the carrier being demodulated. Values range from $\pm 0$ to $\pm 30$ kHz, 100 Hz resolution. Returns 99999 if the demodulator is unlocked.  Example: RFO=+02.3 (which is + 2.3 kHz)	N/A	RFO?	RFO=xxxxx (see description of arguments)
Buffer Fill State	N/A	2 bytes	Query only. Unit returns the value of the buffer fill state, between 1 and 99%. Returns 00 if demodulator is unlocked.  Example: BFS=33 (which is 33%)	N/A	BFS?	BFS=xx (see description of arguments)

Parameter Type	Command (Instruction Code and Qualifier)	Arguments for Command or Response to Query	Description of Arguments	Response to Command	Query (Instruction Code and Qualifier)	Response to Query
<b>Rx BER</b>	N/A	<b>5 bytes</b>	<p><b>Query only.</b> Unit returns the value of the estimated corrected BER in the form <math>a.b \times 10^{-3}</math>. First three bytes are the value. Last two bytes are the exponent. Returns 99999 if the demodulator is unlocked or BER data is unavailable.</p> <p><b>Example: BER=4.8E3 (which is BER=4.8 x 10<sup>-3</sup>)</b></p>	N/A	<b>BER?</b>	<b>BER=x</b> (see description of arguments)
<b>Redundancy State</b>	N/A	<b>1 byte, 0 or 1</b>	<p><b>Query only.</b> Unit returns the redundancy state of the unit, where 0=Offline 1=Online</p> <p><b>Example: RED=1 (which is Online)</b></p>	N/A	<b>RED?</b>	<b>RED=x</b> (see description of arguments)
<b>Local/Remote Status</b>	<b>LRS=</b>	<b>1 byte, 0 or 1</b>	<p><b>Command or Query.</b> Used set the user's Local/Remote status, where: 0=Local 1=Remote</p> <p><b>Example: LRS=1 (which is Remote)</b></p>	<b>LRS=</b> <b>LRS?</b> <b>LRS*</b> <b>LRS#</b>	<b>LRS?</b>	<b>LRS=x</b>
<b>Software Revision</b>	N/A	<b>5 bytes</b>	<p><b>Query only.</b> Unit returns the value of the internal software revision installed in the unit, in the form of x.x.x</p> <p><b>Example: SWR=1.0.3</b></p>	N/A	<b>SWR?</b>	<b>SWR=x.x.x</b> (see description of arguments)
<b>Serial Number</b>	<b>SNO=</b>	<b>9 bytes</b>	<p><b>Query only.</b> Used to set or Query the units 9 digit serial number. Unit returns its S/N in the form xxxxxxxx.</p> <p><b>Example: SNO=176500143</b></p>	N/A	<b>SNO?</b>	<b>SNO=xxxxxxxx</b> (see description of arguments)

Parameter Type	Command (Instruction Code and Qualifier)	Arguments for Command or Response to Query	Description of Arguments	Response to Command	Query (Instruction Code and Qualifier)	Response to Query
<b>3339999999999999999999 Software Checksum</b>	N/A	<b>29 bytes</b>	<p><b>Query only.</b> Unit returns the checksum values for the Boot, Main, and FPGA sections of firmware: <b>Boot:XXXX Main:YYYY FPGA:ZZZZ</b> where: <b>XXXX</b>=the integer sum checksum for the Boot Block. <b>YYYY</b>=the integer sum checksum for the Main Block. <b>ZZZZ</b>=the integer sum checksum for the FPGA Block.</p> <p><b>Example: FCS=Boot:5AB2 Main:81FE FPGA:C5AO</b> (Takes a few seconds to respond.)</p>	N/A	<b>FCS?</b>	<b>FCS=Boot:XXXX Main:YYYY FPGA=ZZZZ</b> (see description of arguments)
<b>Temperature</b>	N/A	<b>3 bytes</b>	<p><b>Query only.</b> Unit returns the value of the internal temperature sensor, in the form of xxx (degrees C).</p> <p><b>Example: TMP=+26</b></p>	N/A	<b>TMP?</b>	<b>TMP=xxx</b> (see description of arguments)

Parameter Type	Command (Instruction Code and Qualifier)	Arguments for Command or Response to Query	Description of Arguments	Response to Command	Query (Instruction Code and Qualifier)	Response to Query
Equipment ID	N/A	10 bytes	<p>Query only. Unit returns the equipment identification and installed options information, in the form abbbcdefgh; where:</p> <p>a=Turbo codec 0=None, 1=Lo-Rate Turbo, 2=Hi-Rate Turbo 3=TPC/LDPC Codec to 5 Mbps 4=TPC/LDPC Codec and FAST option to 10 Mbps 5=TPC/LDPC Codec and FAST option to 20 Mbps</p> <p>bbb=defines the modem model number: 600 is the CDM-600 (this case) 601 is the CDM-600L 602 is the CLM-9600L</p> <p>c=Data Rate Option: 0=Base (to 5 Mbps), 1=to 10 Mbps, 2=to 20 Mbps.</p> <p>d=Higher-order modulation option: 0=None, 1=8-PSK + 8-QAM, 2=16-QAM 3=8-PSK+8-QAM and 16-QAM</p> <p>e=Framing option: 0=None, 1=IBS, 2=IDR 3=IBS and IDR 4=IBS with high-rate ESC 5=IBS with high-rate ESC and IDR</p> <p>f=Drop and Insert/Audio mode 0=None, 1=D&amp;I, 2=Audio, 3=D&amp;I and Audio.</p> <p>g=Special Options: 0=None, 1=Opt1, 2=Opt2, 3=Opt 1 and 2.</p> <p>h=High-Stability Reference module: 0=None, 1=installed</p> <p>Example: EID=1600213300 = CDM-600, Low-Rate Turbo, 8-PSK/IDR/IBS, Drop and Insert, Audio, up to 20 Mbps</p>	N/A	EID?	EID=abbbcdefgh (see description of arguments)
Hardware Revision	N/A	4 bytes	<p>Query only. Unit returns hardware revision level of both main circuit cards, where xx indicates the main (bottom) card, and y indicates the top (modem) card. For units manufactured before Feb 2005, y = 0 For units manufactured after Feb 2005, y = 1 (provides extended IF frequency range)</p>		HRV?	HRV=xx.y (see description of arguments)

- Notes:
1. To achieve LDPC to 20 Mbps, the unit will require the TPC/LDPC Codec, base modem data rate FAST option to 20 Mbps and the LDPC data rate FAST option to 20 Mbps.
  2. D&I FAST option provides access to both Open Network D&I and Closed Network D&I++.

Parameter Type	Command (Instruction Code and Qualifier)	Arguments for Command or Response to Query	Description of Arguments	Response to Command	Query (Instruction Code and Qualifier)	Response to Query
<b>Faults and Status</b>	<b>N/A</b>	<b>6 bytes</b>	<p>Query only. Response is the current fault and status codes, in the form abcdef, where:</p> <p>a = Unit faults:            0=No faults            1=Power supply fault, +5 volts            2=Power supply fault, +12 volts            3=Power supply fault, -5 volts            4=Power supply fault, +18 volts            5=Power supply fault, -12 volts            6=Spare            7=Tx synthesizer lock            8=Rx synthesizer            9=Power cal Checksum error            A=FPGA main chain load fail            B=Turbo FPGA load fail            C=Modem card FPGA load            D=MUX FPGA load            E=Demux FPGA load            F=(Hi-Stab module) No PLL Lock (Note: suppresses TX)</p> <p>b = Tx Traffic status:            0=Tx traffic OK            1=No clock from terrestrial interface            2=Tx FIFO slip            3=AIS detected on incoming data            4=AUPC upper limit reached            5= (Hi-Stab module) Ref Activity fault</p> <p>c = Rx Traffic status:            0=Rx Traffic OK            1=Demodulator unlocked            2=AGC Alarm - signal out of range            3=Demux Lock (Frame SYNC)            4=Spare            5=Buffer Slip            6=AIS detected on incoming data            7=Eb/No alarm            8=Buffer Clock activity</p> <p>d = Open Network:            0=No Faults            1=Loss of Tx frame            2=BER Alarm            3=Loss of Tx multiframe            4=Tx signaling AIS            5=Tx Remote alarm            6=IBS satellite alarm            7=IDR Rx BWA1            8=IDR Rx BWA2            9=IDR Rx BWA3            A=IDR Rx BWA4            B=IDR Tx BWA1            C=IDR Tx BWA2            D=IDR Tx BWA3            E=IDR Tx BWA4</p>	<b>N/A</b>	<b>FLT?</b>	<p><b>FLT=abcdef</b> <b>(see description for details of arguments)</b></p> <p><b>e=Change in fault status since last poll.</b></p> <p><b>f=Change in unit configuration since last poll.</b></p>





Parameter Type	Command (Instruction Code and Qualifier)	Arguments for Command or Response to Query	Description of Arguments	Response to Command	Query (Instruction Code and Qualifier)	Response to Query
<b>Insert Timeslot</b>	<b>ITS=</b>	<b>3 bytes</b>	<p><b>Command or query.</b> <i>(Note different format between command and query.)</i> <b>Command format: ITS=xy</b></p> <p>Where xx = Channel 01 through 24 y = timeslot: 0-9, A=10, B=11, C=12, D=13,...V=31</p>	<p><b>ITS=</b> <b>ITS?</b> <b>ITS*</b> <b>ITS#</b></p>	<b>ITS?</b>	<p><b>ITS=yyyyyyyyyyyyyy</b> <b>yyyyyyyyyy</b></p> <p>indicating all 24 Insert timeslots values associated with the 24 Rx Satellite channels.</p>
<b>Bulk Status Query</b>	<b>N/A</b>	<b>28 bytes</b>	<p><b>Query only.</b> The response has the format: abcccc,dddd,eeffffggggghh, where: a is as LRS? response b is as RED? response cccc is as EBN? response dddd is as BER? response eeee is as BFS? response ffff is as RFO? response gggg is as RSL? response hhh is as TMP? response</p> <p>This command is intended to <u>reduce</u> the need for excessively frequent queries to a modem, and will be useful for a unit in a redundancy system, where the redundancy system has monitoring of its own occurring. The latter 6 parameters are only updated <u>once per second</u>.</p>	<b>N/A</b>	<b>BSQ?</b>	<b>BSQ=abcccc,dddd,eeffffggggghh</b>

Parameter Type	Command (Instruction Code and Qualifier)	Arguments for Command or Response to Query	Description of Arguments	Response to Command	Query (Instruction Code and Qualifier)	Response to Query
<b>Offline Unit Status</b>	<b>N/A</b>	<b>6 bytes</b>	<p><b>Query only. (1:1 set-up)</b>                      This query is sent to the online modem of a 1:1 pair. It provides access to the fault status information (FLT?) of the offline modem. This is the only way to interrogate the status of an offline modem at the distant-end of a link.                      The response format may be:  <b>No1for1</b> which indicates that no 1:1 system has been detected. Presence of a 1kHz signal from the CRS-150 is used to indicate a 1:1 set-up.  <b>NoComm</b> which indicates that a 1kHz signal has been detected, but that there is no (or not yet) a response for the modem.                      abcdef would be the FLT? response information from the offline unit.</p>	<b>N/A</b>	<b>OUS?</b>	<b>OUS=xxxxxx</b>
<b>Force 1:1 Switch</b>	<b>FSW=</b>	<b>None</b>	<p><b>Command only.</b></p> <p>Forces the unit to toggle the Unit Fail relay to the “fail” state for approx 500ms. If the unit is a 1:1 pair, and it is currently the ‘On-Line’ unit, this will force a switchover, so the unit will then be in ‘Standby’ mode. The command is always executed by the unit, regardless of whether it is stand-alone, in a 1:1 pair, or part of a 1:N system.</p> <p><b>This command takes no arguments.</b></p>	<b>FSW=</b> (message ok)	<b>N/A</b>	<b>N/A</b>

**Note:** The following codes are used in the ‘Response to Command’ column:

- = Message ok
- ? Received ok, but invalid arguments found
- \* Message ok, but not permitted in current mode
- # Message ok, but unit is not in **Remote** mode
- ~ Time out of an EDMAC pass-through message (added in version 1.1.5)

# Appendix A. CABLE DRAWINGS

The EIA-530 standard pinout (provided on the CDM-600) is becoming more popular in many applications. However, there are still many occasions when, especially for existing EIA-422/449 and V.35 users, a conversion must be made.

For these situations, the following two cable drawings show EIA-530 to EIA-422/449 DCE conversion, and EIA-530 to V.35 DCE conversion.

The third drawing shows a standard EIA-232 cable for use with the Remote Control Port of the Modem. This should also be used for performing Flash Upgrading via an external PC.

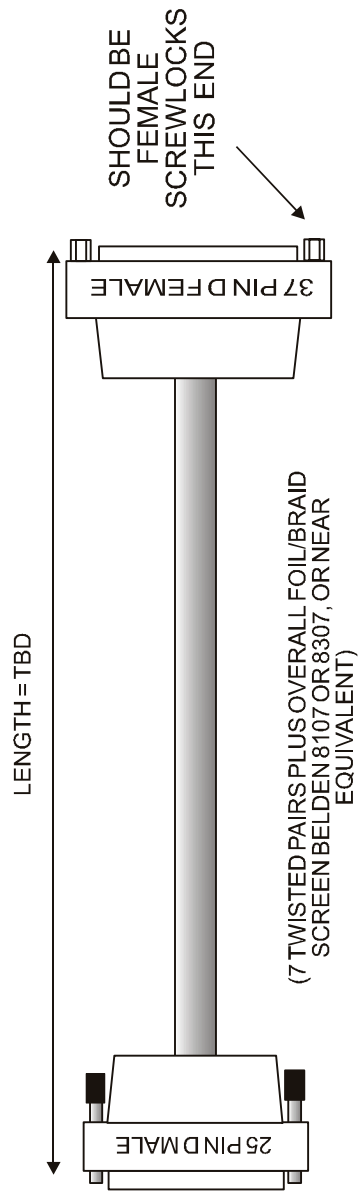
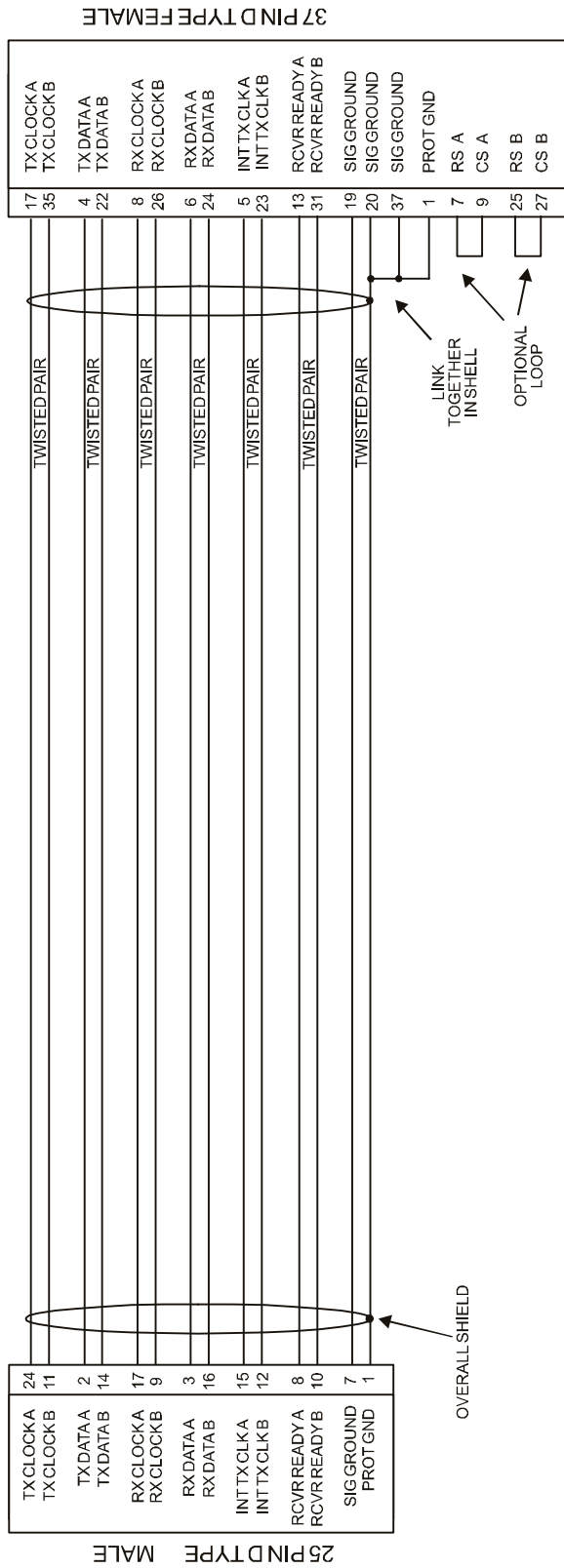

- NOTES:
- USE METAL BACKSHELLS FOR D TYPE CONNECTORS
  - ENSURE SHIELDING FOIL AND/OR BRAID IS BONDED TO METAL BACKSHELL FOR EMC SHIELDING

EIA530 TO RS422/449 DCE CONVERSION CABLE  
(CA/WR0049)

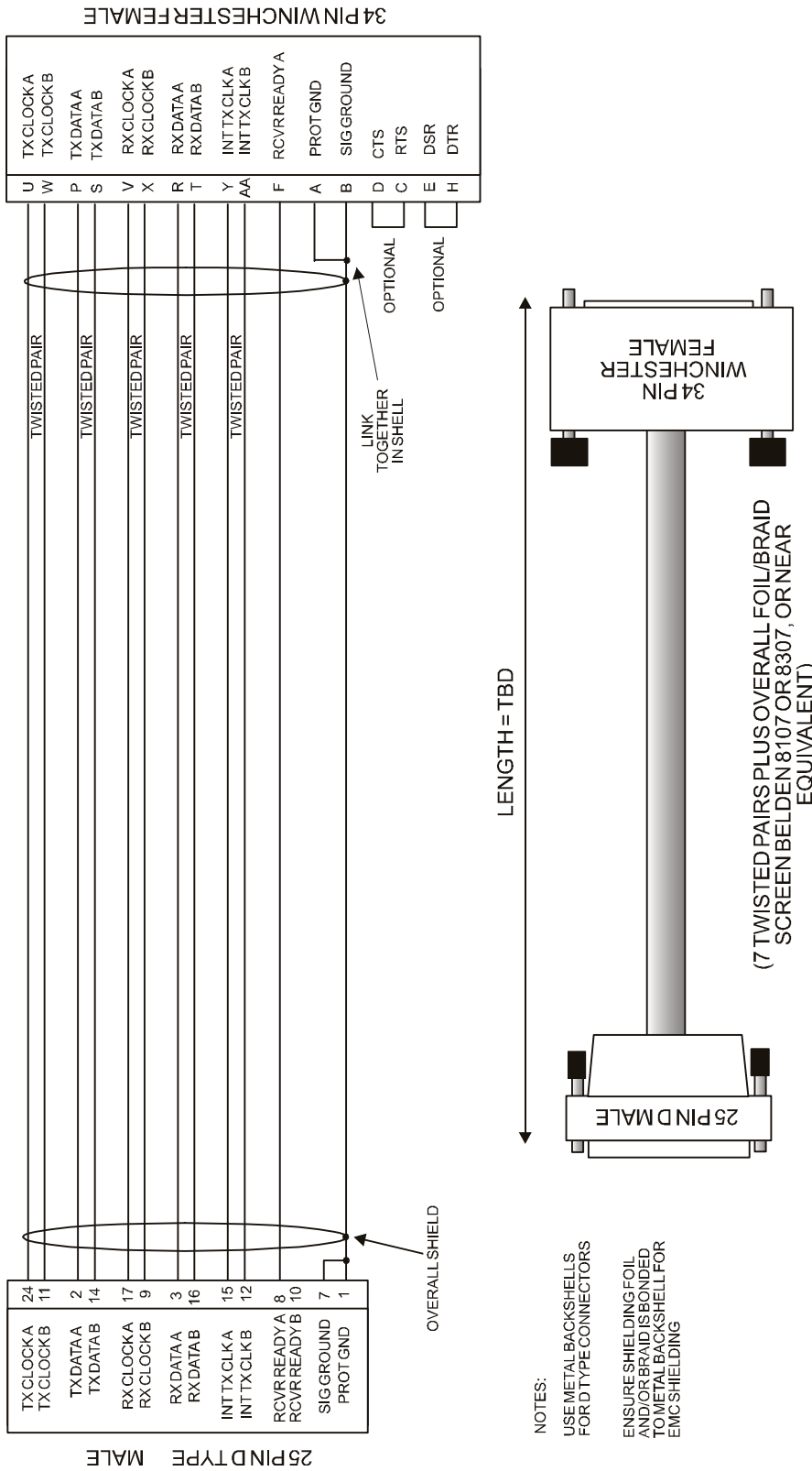

NOTES:  
USE METAL BACKSHELLS FOR D TYPE CONNECTORS  
ENSURE SHIELDING FOIL AND/OR BRAID IS BONDED TO METAL BACKSHELL FOR EMC SHIELDING

EIA530 TO V.35 DCE CONVERSION CABLE

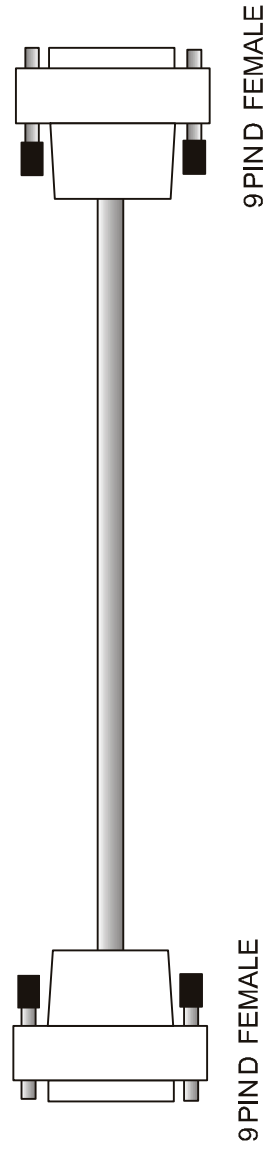
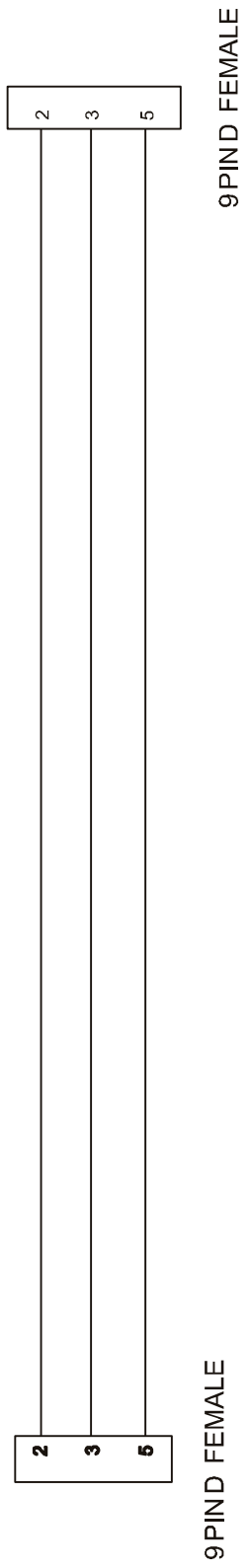

PC 9 PIN SERIAL PORT TO CDM-600 RS232 REMOTE CONTROL PORT

# Appendix B. Eb/No MEASUREMENT

Although the CDM-600 calculates and displays the value of receive Eb/No on the front panel of the unit, it is sometimes useful to measure the value using a spectrum analyzer, if one is available.

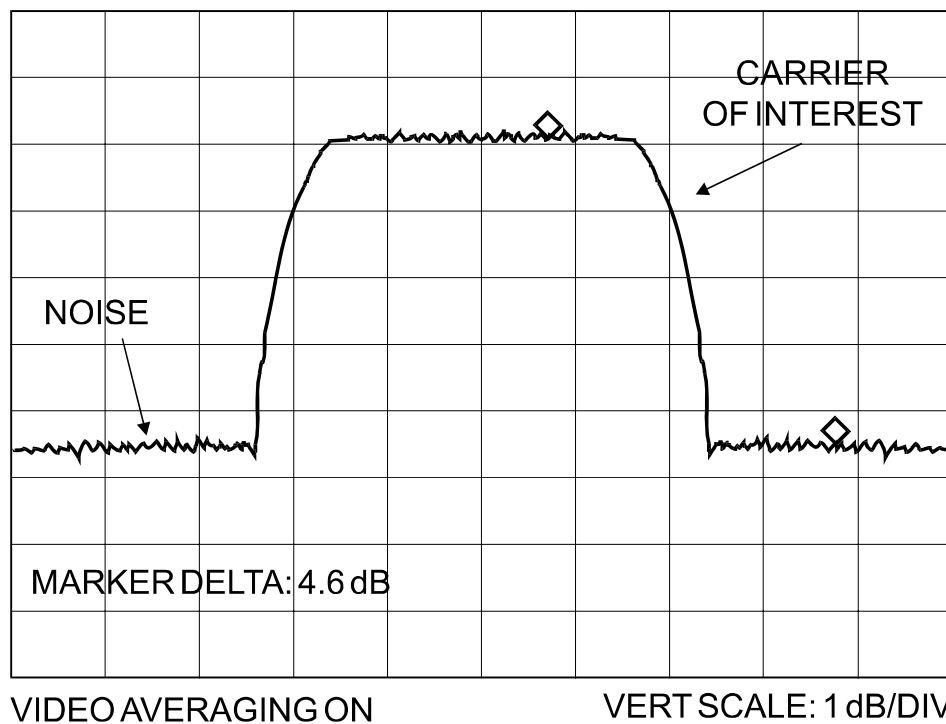

The idea is to accurately measure the value of  $(C+No)/No$ , (Carrier density + Noise density/Noise density). This is accomplished by tuning the center frequency of the Spectrum analyzer to the signal of interest, and measuring the difference between the peak spectral density of the signal (the flat part of the spectrum shown) and the noise density. To make this measurement:

- Use a vertical scale of 1 or 2 dB/division.
- Set the Resolution Bandwidth of the Spectrum Analyzer to < 20 % of the symbol rate.
- Use video filtering and/or video averaging to reduce the variance in the displayed trace to a low enough level that the difference can be measured to within 0.2dB.
- Place a marker on the flat part of the signal of interest, then use the MARKER DELTA function to put a second marker on the noise to the side of the carrier. This value is  $(C+No)/No$ , in dB.
- Use this value of  $(C+No)/No$  in the table on the following page to determine the  $E_b/N_o$ . You will need to know the operating mode to read from the appropriate column.
- If the  $(C+No)/No$  value measured does not correspond to an exact table entry, interpolate using the two nearest values.

Note that the accuracy of this method degrades significantly at low values of  $(C+No)/No$  (approximately less than 6 dB).

**Example:**

In the diagram above, the  $(C+No)/No$  measured is 4.6 dB. If Rate 1/2 QPSK is being used, this would correspond to an  $E_b/N_o$  of approximately 2.6 dB.

The exact relationship used to derive the table values is as follows:

$$E_b/N_o = 10 \log_{10} (10^{(C+No/No)/10} - 1) - 10 \log_{10} (\text{FEC Code Rate}) - 10 \log_{10} (\text{bits/symbol})$$

and:

- $E_b/N_o$  and  $(C+No)/No$  are expressed in dB
- Bits/symbol = 1 for BPSK
- Bits/symbol = 2 for QPSK
- Bits/symbol = 3 for 8-PSK
- Bits/symbol = 4 for 16-QAM
- Code Rate for 'uncoded' = 1
- Pay close attention to the sign of the middle term



**See Chapter 13 for details of how the  $E_b/N_o$  performance degrades when ESC++ is used, particularly at lower data rates, where the percentage overhead is high.**



(Co+No) /No	Eb/No Uncoded BPSK	Eb/No Rate 1/2 BPSK	Eb/No Rate 21/44 BPSK	Eb/No Rate 5/16 BPSK	Eb/No Uncoded QPSK	Eb/No Rate 1/2 QPSK	Eb/No Rate 3/4 QPSK	Eb/No Rate 7/8 QPSK	Eb/No Rate 0.95 QPSK	Eb/No Rate 2/3 8-PSK	Eb/No Rate 3/4 8-PSK	Eb/No Rate 7/8 8-PSK	Eb/No Rate 0.95 8-PSK	Eb/No Rate 3/4 16-QAM	Eb/No Rate 7/8 16-QAM
1.4	-	-	-	0.8	-	-	-	-	-	-	-	-	-	-	-
1.6	-	-	-	1.5	-	-	-	-	-	-	-	-	-	-	-
1.8	-	-	-	2.1	-	-	-	-	-	-	-	-	-	-	-
2.0	-	0.7	0.9	2.7	-	-	-	-	-	-	-	-	-	-	-
2.2	-	1.2	1.4	3.2	-	-	-	-	-	-	-	-	-	-	-
2.4	-	1.7	1.9	3.7	-	-	-	-	-	-	-	-	-	-	-
2.6	-	2.1	2.3	4.2	-	-	-	-	-	-	-	-	-	-	-
2.8	-	2.6	2.8	4.6	-	-	-	-	-	-	-	-	-	-	-
3.0	0.0	3.0	3.2	5.0	-	-	-	-	-	-	-	-	-	-	-
3.5	0.9	3.9	4.1	5.9	-	0.9	-	-	-	-	-	-	-	-	-
4.0	1.8	4.8	5.0	6.8	-	1.8	-	-	-	-	-	-	-	-	-
4.5	2.6	5.6	5.8	7.6	-	2.6	0.8	-	-	-	-	-	-	-	-
5.0	3.3	6.3	6.5	8.4	-	3.3	1.5	0.9	-	-	-	-	-	-	-
5.5	4.1	7.1	7.3	9.1	1.1	4.1	2.3	1.7	1.3	-	-	-	-	-	-
6.0	4.7	7.7	7.9	9.8	1.7	4.7	2.9	2.3	1.9	-	-	-	-	-	-
6.5	5.4	8.4	8.6	10.4	2.4	5.4	3.6	3.0	2.6	-	-	-	-	-	-
7.0	6.0	9.0	9.2	11.1	3.0	6.0	4.2	3.6	3.2	-	-	-	-	-	-
7.5	6.6	9.6	9.8	11.7	3.6	6.6	4.8	4.2	3.8	-	-	-	-	-	-
8.0	7.3	10.3	10.5	12.3	4.3	7.3	5.5	4.9	4.5	-	-	-	-	-	-
8.5	7.8	10.8	11.0	12.9	4.8	7.8	6.0	5.4	5.0	4.8	-	-	-	-	-
9.0	8.4	11.4	11.6	13.4	5.4	8.4	6.6	6.0	5.6	5.4	4.9	-	-	-	-
9.5	9.0	12.0	12.2	14.0	6.0	9.0	7.2	6.6	6.2	6.0	5.5	4.8	-	-	-
10.0	9.5	12.5	12.7	14.6	6.5	9.5	7.7	7.1	6.7	6.5	6.0	5.3	5.0	-	-
10.5	10.1	13.1	13.3	15.1	7.1	10.1	8.3	7.7	7.3	7.1	6.6	5.9	5.6	5.3	-
11.0	10.6	13.6	13.8	15.7	7.6	10.6	8.8	8.2	7.8	7.6	7.1	6.4	6.1	5.8	5.2
11.5	11.2	14.2	14.4	16.2	8.2	11.2	9.4	8.8	8.4	8.2	7.7	7.0	6.7	6.4	5.8
12.0	11.7	14.7	14.9	16.7	8.7	11.7	9.9	9.3	8.9	8.7	8.2	7.5	7.2	6.9	6.3
12.5	12.2	15.2	15.4	17.3	9.2	12.2	10.4	9.8	9.4	9.2	8.7	8.0	7.7	7.4	6.8
13.0	12.8	15.8	16.0	17.8	9.8	12.8	11.0	10.4	10.0	9.8	9.3	8.6	8.3	8.0	7.4
13.5	13.3	16.3	16.5	18.3	10.3	13.3	11.5	10.9	10.5	10.3	9.8	9.1	8.8	8.5	7.9
14.0	13.8	16.8	17.0	18.8	10.8	13.8	12.0	11.4	11.0	10.8	10.3	9.6	9.3	9.0	8.4
14.5	14.3	17.3	17.5	19.4	11.3	14.3	12.5	11.9	11.5	11.3	10.8	10.1	9.8	9.5	8.9
15.0	14.9	17.9	18.1	19.9	11.9	14.9	13.1	12.5	12.1	11.9	11.4	10.7	10.4	10.1	9.5
15.5	15.4	18.4	18.6	20.4	12.4	15.4	13.6	13.0	12.6	12.4	11.9	11.2	10.9	10.6	10.0
16.0	15.9	18.9	19.1	20.9	12.9	15.9	14.1	13.5	13.1	12.9	12.4	11.7	11.4	11.1	10.5
16.5	16.4	19.4	19.6	21.4	13.4	16.4	14.6	14.0	13.6	13.4	12.9	12.2	11.9	11.6	11.0
17.0	16.9	19.9	20.1	21.9	13.9	16.9	15.1	14.5	14.1	13.9	13.4	12.7	12.4	12.1	11.5
17.5	17.4	20.4	20.6	22.4	14.4	17.4	15.6	15.0	14.6	14.4	13.9	13.2	12.9	12.6	12.0
18.0	17.9	20.9	21.1	23.0	14.9	17.9	16.1	15.5	15.1	14.9	14.4	13.7	13.4	13.1	12.5
18.5	18.4	21.4	21.6	23.5	15.4	18.4	16.6	16.0	15.6	15.4	14.9	14.2	13.9	13.6	13.0
19.0	18.9	21.9	22.1	24.0	15.9	18.9	17.1	16.5	16.1	15.9	15.4	14.7	14.4	14.1	13.5
19.5	19.5	22.5	22.7	24.5	16.5	19.5	17.7	17.1	16.7	16.5	16.0	15.3	15.0	14.7	14.1
20.0	20.0	23.0	23.2	25.0	17.0	20.0	18.2	17.6	17.2	17.0	16.5	15.8	15.5	15.2	14.6

Notes: IBS Framing: add 0.2 dB EDMAC Framing: rates below 2048 kbps add 0.2 dB, otherwise 0 Reed-Solomon: add an additional 0.4 dB to the values shown

This page is intentionally blank

# Appendix C. FAST Activation Procedure

---

## C.1 Introduction

FAST is an enhancement feature available in Comtech EF Data products, enabling on-location upgrade of the operating feature set—in the rack—without removing a modem from the setup. This accelerated upgrade can be accomplished only because of FAST's extensive use of programmable devices incorporating Comtech EF Data-proprietary signal processing techniques. These techniques allow the use of a unique access code to enable configuration of the available hardware. The access code can be purchased at any time from Comtech EF Data. Once obtained, the access code is loaded into the unit through the front panel keyboard.

---

## C.2 Activation Procedure

### C.2.1 Serial Number

Obtain the Modem serial number as follows:

- a. From the main menu, select **FAST**, then [ENTER].
- b. The Modem motherboard Serial Number is displayed on the bottom line, to the left.
- c. Record serial number: \_\_\_\_\_

## C.2.2 View currently installed features

To view the currently installed features, proceed as follows:

- a. From the main menu, select **FAST**, then [ENTER].
- b. From the **FAST OPTIONS** menu, select **VIEW**, then [ENTER].
- c. Scroll through the Modem Options and note which are 'Installed' or 'Not Installed'. Any that are 'Not Installed' may be purchased as a FAST upgrade.

Contact a Comtech EF Data sales representative to order features. You will be asked to provide the Modem Serial Number. Comtech EF Data Customer Support personnel will verify the order and provide an invoice and instructions, including a 20-character configuration code.

## C.2.3 Enter Access Codes

Enter the access codes as follows:

- a. Press [CLEAR] to return to the **FAST OPTIONS** menu.
- b. Select **SET**.
- c. Press [ENTER].
- d. Use [←][→] and [↑][↓] arrow keys to enter the 20 character config code.
- e. Press [ENTER].

If everything has been entered correctly, the display will show "CONFIGURED CORRECTLY" and the modem resets to its default configuration.

# Appendix D. ODU OPERATION

---

## D.1 Introduction

The user can fully control and monitor the operation of a Comtech EF Data ODU from the front panel, using the keypad and display of a CDM-600 modem. Nested menus display all available options and prompt the user for required actions. The ODUs that can be controlled are:

- CSAT-5060 series
- KST-2000A
- KST-2000B

The display has two lines each of 24 characters. On most menu screens, a flashing *solid block cursor* blinks once per second to indicate the currently selected item, digit, or field. Where this solid block cursor would obscure the item being edited (for example, a numeric field) the cursor will automatically change to an *underline cursor*. The six key functions are:

<b>ENTER</b>	This key is used to select a displayed function or to execute a modem configuration change.
<b>CLEAR</b>	This key is used to back out of a selection or to cancel a configuration change which has not been executed using [ENTER]. Pressing [CLEAR] generally returns the display to the previous selection.
<b>Left, Right</b> [←], [→]	These arrows are used to move to the next selection or to move the cursor functions. At times, they may also be used to move from one section to another.
<b>Up, Down</b> [↑], [↓]	These arrows are used primarily to change configuration data (numbers). At times, they may also be used to move from one section to another.



The keypad has an auto-repeat feature. If a key is held down for more than 1 second, the key action will repeat, automatically, at the rate of 15 keystrokes per second. This is particularly useful when editing numeric fields, with many digits, such as frequency or data rate.

---

## D.2 MENU TREES

### D.2.1 MODEM MAIN MENU

```
SELECT: CONFIGURATION TEST INFORMATION  
MONITOR STORE/LOAD UTILITY ODU FAST
```

The user is presented with the following choices:

<b>CONFIGURATION</b>	permits the user to fully configure the modem.
<b>TEST</b>	permits the user invoke one of several modem Test Modes.
<b>INFORMATION</b>	permits the user to view modem information, without having to go into configuration screens.
<b>MONITOR</b>	permits the user to monitor the alarm status of the modem, to view the log of stored events, and to display the Receive Parameters screen.
<b>STORE/LOAD</b>	permits the user to store and to retrieve up to 10 different modem configurations.
<b>UTILITY</b>	permits the user to perform miscellaneous functions, such as setting the Real-time clock, adjusting the display brightness, etc.
<b>ODU</b>	(Outdoor Unit). This permits the user to monitor and control a Comtech EF Data RF Transceiver (CSAT or KST-2000A/B), if connected.
<b>FAST</b>	permits the user to view or edit the modem FAST options.

The ODU menu item is described in this section, in detail.

## D.2.2 ODU

```
ODU CONTROL=ENABLE      (DISABLE/ENABLE)
SYSTEM TYPE=STANDALONE  (STANDALONE,1:1)
```

ODU CONTROL: either ENABLE or DISABLE - turns on or off the FSK link to the ODU.

SYSTEM TYPE: either STANDALONE or 1:1.

STANDALONE should be selected when the Modem is linked via the Rx IF cable to a single Comtech EF Data ODU. Selecting STANDALONE for a CSAT will take the user to the menu shown in paragraph D.2.5. If the modem detects a KST, the user will be taken to the menu shown in paragraph D.2.27.

1:1 should be selected when the Modem is linked to a redundant CSAT system via connection between the Rx IF and the ODU Redundancy Controller Box. Selecting 1:1 will take the user to the menu shown next.

## D.2.3 (ODU)

## ENABLE, 1:1

```
1:1 MONITOR & CONTROL:
ODU#1   ODU#2   REDUNDANCY-BOX
```

Use the [←] or [→] arrow keys to select the menu option, then press ENTER.

Selecting ODU#1 or ODU#2 will take the user to the menu of paragraph D.2.5. Selecting REDUNDANCY-BOX will take the user to the following menu.

## D.2.4 (ODU,ENABLE,1:1)

## REDUNDANCY BOX

```
RED: ONLINE:ODU2  MODE:AUTO  SWITCH:N  
TXSW:OK  RXSW:OK  5V:5.0  12V:12.0
```

There are two modes that can be edited:

- AUTO
- MANUAL

This is the indication of the current operating mode of the 1:1 ODU system. In Auto mode, when the Online ODU faults, the switchover is done automatically to replace the faulty unit.

SWITCHOver: either Yes or No (Default: No.)

The Online unit is indicated to the left of the screen. The user may force a Switchover to the other unit. To do so, position the cursor to the Switch position. Press the [↑] or [↓] key to select Yes and press ENTER

**NOTE:** If the ODU Redundancy system is in AUTO mode, a ‘forced switch-over’ can only occur if the currently OFFLINE unit is fault-free.

Additional information shown on this screen:

Waveguide Switch status, both Tx and Rx: OK or FT (fault).

Redundancy Controller Box voltages: 5V and 12V values. These can assist in trouble-shooting system problems.

## D.2.5 (ODU,ENABLE,1:1) CSAT#1 (ODU,ENABLE,1:1) CSAT#2 (ODU,ENABLE,STANDALONE CSAT)

```
SELECT: CONFIGURATION  MONITOR  ALARMS  
INFORMATION
```

Use the [←] or [→]keys to select the menu option, then press ENTER.



**D.2.6 (ODU,ENABLE,1:1,CSAT#1) CONFIGURATION**  
**(ODU,ENABLE,1:1,CSAT#2) CONFIGURATION**  
**(ODU,ENABLE,STANDALONE CSAT) CONFIGURATION**

```
CONFIG: TX-PARAMETERS  RX-PARAMETERS  
        LNA-PARAMETERS  MISCELLANEOUS
```

Use the [←] or [→] keys to select the parameters to configure, then press ENTER.

**D.2.7 (ODU,ENABLE,1:1,CSAT#1,CONFIG) TX**  
**(ODU,ENABLE,1:1,CSAT#2,CONFIG) TX**  
**(ODU,ENABLE,STANDALONE CSAT,CONFIG) TX**

```
TX:  FREQ=6427.0 MHz  ATT=23.00 dB  
     AMP=OFF         MUTE=UNMUTED  SLOPE
```

Use the [←] or [→] keys to select the parameter to edit. Use the [↑] or [↓] keys to edit the parameter, then press ENTER to implement, or CLEAR.

The user may edit the TX Frequency, the TX Attenuation, the Amplifier setting or the Mute setting. The Slope parameters are edited in another menu, so use the [←] or [→] keys to select Slope and press ENTER.

**D.2.8 (ODU,ENABLE,1:1,CSAT#1,CONFIG,TX) SLOPE**  
**(ODU,ENABLE,1:1,CSAT#2,CONFIG,TX) SLOPE**  
**(ODU,ENABLE,STANDALONE CSAT,CONFIG,TX) SLOPE**

```
TX SLOPE:  MODE=MANUAL  (MANUAL, CAL)  
           SLOPE=0.3    (0.0 - 1.0)
```

Use the [←] or [→] keys to select the parameter to edit. Use the [↑] or [↓] keys to edit the parameter, then press ENTER to implement, or CLEAR.

The Slope Mode may be either CALIBRATED or MANUAL. If MANUAL is selected, the Slope may be edited.

**D.2.9 (ODU,ENABLE,1:1,CSAT#1,CONFIG) RECEIVER**  
**(ODU,ENABLE,1:1,CSAT#2,CONFIG) RECEIVER**  
**(ODU,ENABLE,STANDALONE CSAT,CONFIG) RECEIVER**

```
RX: FREQ=3600.0 MHz    ATT=18.00 dB  
      MUTE=UNMUTED    SLOPE
```

Use the [←] or [→] arrow keys to select the parameter to edit. Use the [↑] or [↓] keys to edit the parameter, then press ENTER to implement, or CLEAR.

The user may edit the RX Frequency, the RX Attenuation or the Mute setting. The Slope parameters are edited in another menu, so use the [←] or [→] keys to select Slope and press ENTER.

**D.2.10 (ODU,ENABLE,1:1,CSAT#1,CONFIG,RX) SLOPE**  
**(ODU,ENABLE,1:1,CSAT#2,CONFIG,RX) SLOPE**  
**(ODU,ENABLE,STANDALONE CSAT,CONFIG,RX) SLOPE**

```
RX SLOPE:  MODE=MANUAL  (MANUAL, CAL)  
           SLOPE=0.2    (0.0 - 1.0)
```

Use the [←] or [→] keys to select the parameter to edit. Use the [↑] or [↓] keys to edit the parameter, then press ENTER to implement, or CLEAR.

The slope mode may be either CALIBRATED or MANUAL. If MANUAL is selected, the slope may be edited.

**D.2.11 (ODU,ENABLE,1:1,CSAT#1,CONFIG) LNA**  
**(ODU,ENABLE,1:1,CSAT#2,CONFIG) LNA**  
**(ODU,ENABLE,STANDALONE CSAT,CONFIG) LNA**

```
LNA: STATE=OFF CALIBRATE-LNA-CURRENT=NO
CURRENT-WINDOW=48% FAULT-LOGIC=SUMMARY
```

Use the [←] or [→] keys to select the parameter to edit. Use the [↑] or [↓] keys to edit the parameter, then press ENTER to implement, or CLEAR.

<b>LNA STATE</b>	either OFF or ON - controls whether or not the CSAT will provide LNA Power via the Receive RF Cable.
<b>CALIBRATE-LNA-CURRENT</b>	Selecting YES and pressing ENTER calibrates the LNA current for use with the Current-Window function. (Default is NO)
<b>CURRENT WINDOW:</b>	Values will scroll between 20% and 50% to define the allowable LNA Current change before declaring a fault. Selecting 99% disables the Current Window function.
<b>FAULT-LOGIC:</b>	either SUMMARY or NO_SUMMARY. This controls whether or not a LNA Current-Window fault will activate the Summary Fault Relay. This allows the user to select whether or not to switch the Online/Offline CSAT in the event of a LNA Current-Window fault.

**D.2.12 (ODU,ENABLE,1:1,CSAT#1,CONFIG) MISCELLANEOUS**  
**(ODU,ENABLE,1:1,CSAT#2,CONFIG) MISCELLANEOUS**  
**(ODU,ENABLE,STANDALONE CSAT,CONFIG)MISCELLANEOUS**

```
MISC:  COLD-START=DISABLE  AFR=ENABLE
        XREF=NO           REF-ADJUST=087  RTC=OFF
```

Use the [←] or [→] keys to select the parameter to edit. Use the [↑] or [↓] keys to edit the parameter, then press ENTER to implement, or CLEAR.

<b>COLD-START</b>	If enabled, when the CSAT is powered on, the IF and RF outputs will remain muted for 15 minutes.
<b>AFR</b>	Auto Fault Recovery: this defines how a CSAT will react to momentary fault conditions.
<b>AFR=OFF:</b>	A fault will cause the CSAT to mute and remain muted.
<b>AFR=ON</b>	The CSAT will mute when faulted, but unmute after the fault goes away.
<b>XREF – external Reference:</b>	The CSAT will automatically lock to an external 5 or 10 MHz reference independent of the state of this selection. This selection determines whether or not the Summary Fault Relay is activated if the CSAT loses lock with the external reference.
<b>REF-ADJUST:</b>	The user may edit the Internal 10MHz Reference setting. The value will scroll between 000 and 255.  <b>NOTE:</b> The Internal Reference is adjusted in the factory to be very accurate with the default setting of 087. This parameter is made available to compensate for the long-term frequency drift of the oscillator.
<b>RTC- Real Time Clock:</b>	Selecting YES and pressing ENTER will cause the CSAT RTC to be synchronized to the Modem RTC. (Default is NO.)

- D.2.13 (ODU,ENABLE,1:1,CSAT#1) MONITOR**  
**(ODU,ENABLE,1:1,CSAT#2) MONITOR**  
**(ODU,ENABLE,STANDALONE CSAT) MONITOR**

```
MONITOR:  TRANSMIT  RECEIVE  MISCELLANEOUS  
          POWER-SUPPLIES
```

Use the [←] or [→] keys to select the parameters to monitor, then press ENTER.

- D.2.14 (ODU,ENABLE,1:1,CSAT#1, MONITOR) TX**  
**(ODU,ENABLE,1:1,CSAT#2, MONITOR) TX**  
**(ODU,ENABLE,STANDALONE CSAT, MONITOR) TX**

```
TX:  SYNTUNE = 09.6 VDC  POWER = <24 dBm  
     IFLO = 11.1 VDC    TEMP = 26 C
```

Press ENTER or CLEAR to return to previous menu.

- D.2.15 (ODU,ENABLE,1:1,CSAT#1, MONITOR) RX**  
**(ODU,ENABLE,1:1,CSAT#2, MONITOR) RX**  
**(ODU,ENABLE,STANDALONE CSAT, MONITOR) RX**

```
RX:  SYNTUNE = 01.4 VDC  
     IFLO = 11.2 VDC    TEMP = 26 C
```

Press ENTER or CLEAR to return to previous menu.

- D.2.16 (ODU,ENABLE,1:1,CSAT#1, MONITOR) MISC**  
**(ODU,ENABLE,1:1,CSAT#2, MONITOR) MISC**  
**(ODU,ENABLE,STANDALONE CSAT, MONITOR) MISC**

```
MISC: REF TUNE = 03.0 VDC  
      LNA = 00.05 mA  FAN = 550 mA
```

Press ENTER or CLEAR to return to previous menu.

**D.2.17 (ODU,ENABLE,1:1,CSAT#1, MONITOR) PWR-SUPPLIES**  
**(ODU,ENABLE,1:1,CSAT#2, MONITOR) PWR-SUPPLIES**  
**(ODU,ENABLE,STANDALONE CSAT, MONITOR) PWR-SUPPLIES**

```
24V=24.1 VDC 12V=12.5VDC +5V=+5.4VDC  
20V=21.2 VDC 10V=10.2VDC -5V=-5.3VDC
```

Press ENTER or CLEAR to return to previous menu.

**D.2.18 (ODU,ENABLE,1:1,CSAT#1) ALARMS**  
**(ODU,ENABLE,1:1,CSAT#2) ALARMS**  
**(ODU,ENABLE,STANDALONE CSAT) ALARMS**

```
ALARMS: CURRENT-ALARMS STORED-ALARMS
```

Use the [←] or [→] keys to select the type of alarms to view, then press ENTER.

**D.2.19 (ODU,ENABLE,1:1,CSAT#1, ALARMS) CURRENT-ALARMS**  
**(ODU,ENABLE,1:1,CSAT#2, ALARMS) CURRENT-ALARMS**  
**(ODU,ENABLE,STANDALONE CSAT, ALARMS)CURRENT-ALARMS**

```
CURRENT STATUS: TX = OK RX = OK  
POWER-SUPPLY = OK MISC = OK
```

Press ENTER or CLEAR to return to previous menu.

**D.2.20 (ODU,ENABLE,1:1,CSAT#1, ALARMS) STORED-ALARMS**  
**(ODU,ENABLE,1:1,CSAT#2, ALARMS) STORED-ALARMS**  
**(ODU,ENABLE,STANDALONE CSAT, ALARMS) STORED-ALARMS**

As the stored events are being read, the screen will show:

```
READING STORED FAULTS..... PLEASE WAIT
```

Then, the Stored Alarms screen will be shown. An example is shown below:

```
STORED ALARMS: CLEAR-ALL: NO (NO,YES)  
IF #84: 10/14/04 12:52:08 POWER ON
```

Use the [←] or [→] keys to select between the log entries and the CLEAR-ALL option.

With the cursor on the entry number, use the [↑] or [↓] keys to view through the entries.

Up to 99 entries are stored. Each entry shows:

the entry type: IF = information, FT = fault, OK = fault cleared

the entry number – 00 through 99

the date (international format)

the time

a description of the fault/information

To clear the Stored Alarms Log, select YES in the CLEAR-ALL option and press ENTER.

**D.2.21 (ODU,ENABLE,1:1,CSAT#1) INFORMATION**  
**(ODU,ENABLE,1:1,CSAT#2) INFORMATION**  
**(ODU,ENABLE,STANDALONE CSAT) INFORMATION**

```
INFO: MODEL TX RX MISC LNA
```

Use the [←] or [→] keys to select the type of information to view, then press ENTER.

**D.2.22 (ODU,ENABLE,1:1,CSAT#1,INFO) MODEL**  
**(ODU,ENABLE,1:1,CSAT#2,INFO) MODEL**  
**(ODU,ENABLE,STANDALONE CSAT,INFO) MODEL**

```
MODEL: CSAT-5060/025 V2.19
S/N: 010300346
```

Press ENTER or CLEAR to return to previous menu.

**D.2.23 (ODU,ENABLE,1:1,CSAT#1,INFO) TX**  
**(ODU,ENABLE,1:1,CSAT#2,INFO) TX**  
**(ODU,ENABLE,STANDALONE CSAT,INFO) TX**

```
INFO: TX:OFF 6427.0MHz 23.00dB
AMP:OFF UNMUTED SLOPE:0.3
```

Press ENTER or CLEAR to return to previous menu.

This window shows Tx Frequency, Tx Attenuation, Amplifier state, Tx Mute state and Tx Slope adjustment (value or CAL).

**D.2.24 (ODU,ENABLE,1:1,CSAT#1,INFO) RX**  
**(ODU,ENABLE,1:1,CSAT#2,INFO) RX**  
**(ODU,ENABLE,STANDALONE CSAT,INFO) RX**

```
INFO: RX:ON 3400.0MHz 18.00dB
REF:087 UNMUTED SLOPE:0.2
```

Press ENTER or CLEAR to return to previous menu.

This window shows Rx Frequency, Rx Attenuation, Amplifier state, Rx Mute state and Rx Slope adjustment (value or CAL).



- D.2.25 (ODU,ENABLE,1:1,CSAT#1,INFO) MISC**  
**(ODU,ENABLE,1:1,CSAT#2,INFO) MISC**  
**(ODU,ENABLE,STANDALONE CSAT,INFO) MISC**

```
INFO:          COLD START:OFF
          AUTO FAULT RECOVERY:SUMMARY
```

Press ENTER or CLEAR to return to previous menu.

- D.2.26 (ODU,ENABLE,1:1,CSAT#1,INFO) LNA**  
**(ODU,ENABLE,1:1,CSAT#2,INFO) LNA**  
**(ODU,ENABLE,STANDALONE CSAT,INFO) LNA**

```
INFO:  LNA:OFF      FAULT-LOGIC:SUMMARY
          WINDOW:48%
```

Press ENTER or CLEAR to return to previous menu.

- D.2.27 (ODU) ENABLE,STANDALONE KST**

```
KST SELECT:
          CONFIGURATION INFORMATION  ALARMS
```

Use the [←] or [→] keys to select the menu option, then press ENTER.

- D.2.28 (ODU,ENABLE,STANDALONE KST) CONFIGURATION**

```
KST CONFIG:
          TX-PARAM  RX-PARAM  MISCELLANEOUS
```

Use the [←] or [→] keys to select the parameters to configure, then press ENTER.

### D.2.29 (ODU,ENABLE,STANDALONE KST,CONFIG)

**TX**

```
TX:OFF      FREQ=13955 MHz      ATT=23 dB
              AGC=OFF
```

Use the [←] or [→] keys to select the parameter to edit. Use the [↑] or [↓] keys to edit the parameter, then press ENTER to implement, or CLEAR.

The user may edit the TX Frequency, the TX Attenuation, the Amplifier setting or the AGC setting.

### D.2.30 (ODU,ENABLE,STANDALONE KST,CONFIG)

**RX**

```
RX: FREQ=11950 MHz      ATT=20 dB      REF=087
      BAND=B
```

**Note:** The RX Band is not shown for the KST-2000A.

Use the [←] or [→] keys to select the parameter to edit. Use the [↑] or [↓] keys to edit the parameter, then press ENTER to implement, or CLEAR.

The user may edit the RX Frequency, the RX Attenuation, the Ref setting or the RX Band (KST-2000B only).

### D.2.31 (ODU,ENABLE,STANDALONE KST,CONFIG)

**MISC**

```
HPA:OFF      FAULT-LOGIC=SUMMARY
LNA:OFF      FAULT-LOGIC=SUMMARY      CAL:NO
```

Use the [←] or [→] keys to select the parameter to edit. Use the [↑] or [↓] keys to edit the parameter, then press ENTER to implement, or CLEAR.

<b>HPA state</b>	either OFF or ON - HPA power enable
<b>FAULT-LOGIC</b>	either SUMMARY or NO_SUMMARY. This controls whether or not a HPA fault will be indicated on the Fault status and will activate the Summary Fault Relay.
<b>LNA state</b>	either OFF or ON - LNA power enable.
<b>FAULT-LOGIC</b>	either SUMMARY or NO_SUMMARY. This controls whether or not a LNA fault will be indicated on the Fault status and will activate the Summary Fault Relay.
<b>CAL</b>	To calibrate, select YES and press ENTER. Calibration allows the system to determine nominal LNB or LNB power consumption, performed at initial installation only. (Default is NO.)

### D.2.32 (ODU,ENABLE,STANDALONE KST)

### INFORMATION

```
KST INFO:  MODEL  TX+RX-PARAM
           MISC   NUMBERS
```

Use the [←] or [→] arrow keys to select the type of information to view, then press ENTER.

### D.2.33 (ODU,ENABLE,STANDALONE KST,INFO)

### MODEL

```
MODEL:  KST-2000B
HPA:    CEFD-SSPA
```

Press ENTER or CLEAR to return to previous menu.

### D.2.34 (ODU,ENABLE,STANDALONE KST,INFO)

### TX+RX-PARAM

```
INFO: TX:OFF  13955MHz  10dB
      RX:      11950MHz  20dB  REF:087
```

Press ENTER or CLEAR to return to previous menu.

### D.2.35 (ODU,ENABLE,STANDALONE KST,INFO)

### MISC

```
INFO:      HPA:OFF  FLT-LOGIC:NO-SUMM
      Band:B  LNA:OFF  FLT-LOGIC:SUMMARY
```

Press ENTER or CLEAR to return to previous menu.

**Note:** The RX Band information is not shown for the KST-2000A.

### D.2.36 (ODU,ENABLE,STANDALONE KST,INFO)

### NUMBERS

```
M&C:      F/W:9364-1B      VER:01.01.03
          assy:9357-1A      S/N:021476493
```

Press the [↑] or [↓] keys to view further Number information, for the Up Converter, Down Converter and HPA assemblies.

Press ENTER or CLEAR to return to previous menu.

### D.2.37 (ODU,ENABLE,STANDALONE KST)

### ALARMS

```
CURRENT STATUS:  UP:OK  REF:OK  AGC:OK
                  P-SUPPLIES:OK  DN:OK  HPA:OK  LNA:OK
```

This is Summary Status information. Use the [←] or [→] keys to select one of Up, Ref, AGC, P-supplies, Down or HPA, then press ENTER. A detail Status screen will be shown:

```
UP-CONVERTER:   COMMS:OK   L-SYNTH:OK
                  OVER-TEMP:OK   Ku-SYNTH:OK
```

```
REFERENCE:WARM   72M-LOCK:OK   RANGE:NA
SOURCE:INT       xREF-LOCK:NA   PHASE:NA
```

```
AGC STATUS:      EXCESS-POWER-IN:OK
                  LOOP-CONV:OK   INSUFF-POWER-IN:OK
```

```
P-SUPPLIES:     7V:OK   17V:OK
                  -7V:OK   12V:OK   (ENTER)
```

```
DOWN-CONVERTER: COMMS:OK   L-SYNTH:OK
                  OVER-TEMP:OK   Ku-SYNTH:OK
```

```
HPA:            COMMS:OK   9.75V:OK
                  OVER-TEMP:OK   BIAS:OK   -CONV:5V:OK
```

Press ENTER or CLEAR to return to previous menu.

# Index

1:1 manual switch, 6-41  
16-QAM Viterbi, Rate 3/4, 7-25  
8-PSK/TPC Coding Summary 7-6  
8-PSK/TPC Rate 2/3, 7-20

## A

Activation Procedure, 1-6  
Address, 6-26, 6-34, 16-2, 16-3, 16-18,  
16-23  
Alarm, 6-2, 6-36, 9-1, 9-3, 9-4, 12-3, 16-  
15, 16-18, 16-20, 16-21, 16-22, 16-26,  
16-37  
AUPC, 1-2, 1-4, 6-6, 6-9, 6-10, 6-38, 6-  
39, 11-3, 12-1, 12-2, 12-3, 12-4, 15-1,  
15-7, 16-12, 16-13, 16-14, 16-18, 16-  
20, 16-37  
Automatic Uplink Power Control, 1-2, 12-  
1, 15-2

## B

Backward Alarms, 6-28  
Basic Protocol, 16-2  
Buffer Disabled, 10-3  
Buffer Enabled, 10-3

## C

Compatibility, 1-8  
Compensation Rate, 12-3  
CONFIG, 6-6, 6-7, 6-8, 6-9, 6-10, 6-11,  
6-12, 12-2, C-1, C-2

CLOCKS, 6-19  
DROP TIMESLOTS, 6-22  
EDMAC, 6-23  
HIGH-RATE ESC, 6-25  
IMPEDANCE, 6-29  
INSERT TIMESLOTS, 6-23  
MASKS, 6-27  
REMOTE CONTROL, 6-26  
RX, 6-14  
RX PARAMTERS, 6-39  
STATISTICS, 6-29  
STATS, 6-38  
TERNARY CODES, 6-24  
WARM-UP DELAY, 6-25  
Configuration, 2-4, 6-5, 16-18, 16-28, 16-  
29  
Connect External Cables, 2-4

## D

D&I Framing, 9-3  
D&I Primary Data Interfaces, 9-3  
D&I++, 1-2, 6-20, 10-6, 10-7, 10-8, 11-4,  
12-1, 15-2, 15-7, 16-9, 16-15, 16-17,  
16-20, 16-22, 16-36  
Data Interfaces, 1-3  
Demod Unlock, 12-3  
Demodulator, 15-7, 16-20, 16-37  
Dimensional Envelope, 4-6  
Drop & Insert ++, 11-4, 15-1  
Drop and Insert, 1-1, 1-5, 6-22, 9-1, 9-2,  
10-1, 10-3, 10-6, 10-9, 15-1, 15-6, 16-  
20, 16-36, 16-38  
Drop and Insert Clocking, 10-9

- E**
- EbNo Alarm Pt, 6-19
  - EIA-232, 1-3, 4-3, 4-4, 6-26, 9-1, 9-2, 9-3, 10-1, 14-1, 15-6, 15-7, 15-9, 16-1, 16-2, 16-3, A-1
  - EIA-485, 6-26, 15-9, 16-1, 16-2, 16-3
  - End Of Packet, 16-5
  - External Clock, 10-2, 10-3, 15-2, 15-6, 16-14
  - External Frequency Reference, 6-21
  - External Reference, 6-6, 15-6, 16-18, 16-21
- F**
- FAST, 1-4, 1-5, 1-6, 4-3, 6-5, 6-7, 6-8, 6-10, 6-12, 6-13, 6-15, 6-17, 6-18, 6-22, 6-42, 15-6, C-1, C-2
  - FAST Accessible Options, 1-6
  - FAST Activation Procedure, C-1, D-1
  - FAST Options and Hardware Options, 1-4
  - FAST System Theory, 1-6
  - Flash Upgrading, A-1
  - Frame formats, 10-7
  - Front Panel, 4-1, 6-1, 6-2
  - Front Panel Operation, 4-1
- H**
- Hardware Options, 1-7, 1-8
  - High Stability Reference, 1-4
  - High-stability, 15-2
  - High-Stability Internal/External Reference, 1-7
- I**
- IBS Clock/data recovery and De-jitter, 9-2
  - IBS Engineering Service Channel, 9-2
  - IBS Framing, 9-2
  - IBS Scrambling, 9-2
  - IDR Engineering Service Channel, 9-5
  - IDR Primary Data Interfaces, 9-5
  - Implementation, 1-6
  - Installation, 1-5, 2-3
  - Installation of the Mounting Bracket, 2-2
  - Instruction Code, 16-4, 16-18, 16-20, 16-21
  - Instruction Code Qualifier, 16-4
  - Internal Clock, 10-1, 10-2
  - Internal Reference, 6-21
- L**
- Loop-Timed, 10-2, 16-14
- M**
- M&C Connection, 11-2
  - Main Menu, 6-5
  - Major Assemblies, 1-4
  - Max Range, 12-2
  - Message Arguments, 16-5
  - Modulator, 6-30
  - MONITOR, 6-5, 6-36, 12-4
  - AUPC, 6-39
  - Monitoring, 12-4
  - Mounting, 2-2, 2-3
- O**
- Opening Screen, 6-5
  - Operating modes, 15-1
- P**
- Packet Structure, 16-3
- R**
- Real Time Clock, 6-40
  - Rear Panel, 4-2
  - Receive Clocking, 10-3
  - Remote Control, 4-4, 6-6, 15-7, A-1
  - RTC, 16-22, 16-28, 16-29
  - Rx Buffer Clock = Insert (D&I only), 10-10
- S**
- Select Internal IF Loop, 2-4
  - Sequential, 1-1, 1-4, 3-1, 6-10, 6-15, 15-2, 15-3, 16-17
  - Setting AUPC Parameters, 12-2
  - Setup Summary, 11-3
  - Software – Flash Upgrading, 1-3
  - Standard Features, 1-2
  - Start Of Packet, 16-3
  - STATISTICS, 6-38
  - STORE/LOAD, 6-5, 6-39
  - STORED EVENTS, 6-37
  - Supporting Hardware and Software, 1-8
- T**
- Target Eb/No, 12-2, 15-7
  - TEST, 2-4, 6-5, 6-30
  - Theory Of Operation, 11-1

Time Slot Selection, 10–8  
Transmit Clocking, 10–1

**U**

Unpacking, 2–1  
UTILITIES, 6–40

**V**

Verification, 1–3  
Viterbi, 1–1, 1–4, 3–1, 6–2, 6–10, 6–15, 15–  
2, 15–3, 16–17

**X**

X.21 Notes, 10–3

Notes:



## METRIC CONVERSIONS

---

### Units of Length

Unit	Centimeter	Inch	Foot	Yard	Mile	Meter	Kilometer	Millimeter
1 centimeter	—	0.3937	0.03281	0.01094	$6.214 \times 10^{-6}$	0.01	—	—
1 inch	2.540	—	0.08333	0.2778	$1.578 \times 10^{-5}$	0.254	—	25.4
1 foot	30.480	12.0	—	0.3333	$1.893 \times 10^{-4}$	0.3048	—	—
1 yard	91.44	36.0	3.0	—	$5.679 \times 10^{-4}$	0.9144	—	—
1 meter	100.0	39.37	3.281	1.094	$6.214 \times 10^{-4}$	—	—	—
1 mile	$1.609 \times 10^5$	$6.336 \times 10^4$	$5.280 \times 10^3$	$1.760 \times 10^3$	—	$1.609 \times 10^3$	1.609	—
1 mm	—	0.03937	—	—	—	—	—	—
1 kilometer	—	—	—	—	0.621	—	—	—

### Temperature Conversions

Unit	° Fahrenheit	° Centigrade
32° Fahrenheit	—	0 (water freezes)
212° Fahrenheit	—	100 (water boils)
-459.6° Fahrenheit	—	273.1 (absolute 0)

Formulas
$C = (F - 32) * 0.555$
$F = (C * 1.8) + 32$

### Units of Weight

Unit	Gram	Ounce Avoirdupois	Ounce Troy	Pound Avoir.	Pound Troy	Kilogram
1 gram	—	0.03527	0.03215	0.002205	0.002679	0.001
1 oz. avoir.	28.35	—	0.9115	0.0625	0.07595	0.02835
1 oz. troy	31.10	1.097	—	0.06857	0.08333	0.03110
1 lb. avoir.	453.6	16.0	14.58	—	1.215	0.4536
1 lb. Troy	373.2	13.17	12.0	0.8229	—	0.3732
1 kilogram	$1.0 \times 10^3$	35.27	32.15	2.205	2.679	—



---

2114 WEST 7TH STREET TEMPE ARIZONA 85281 USA  
480 • 333 • 2200 PHONE  
480 • 333 • 2161 FAX