

# UT-4514/X Ku-Band Up Converter



## APPLICATION

The Comtech EF Data (CEFD) UT-4514/X Up Converter is the ultimate in high performance and cost effective Ku-Band frequency conversion. The UT-4514/X can be used for SCPC, DAMA, and TDMA, as well as full transponder HDTV and analog TV. Spectral purity and stability characteristics fully meet or exceed the requirements of all domestic, international, and regional commercial satellite networks.

## HIGH GAIN

The UT-4514/X has +10 dBm minimum output level at the 1 dB compression point and 35 dB of gain as a standard. This capability permits longer cable runs to the modem rack or compensates for elaborate splitting networks without adding expensive options such as external line amplifiers.

## LOW PHASE NOISE

The phase noise performance of the UT-4514/X exceeds the Intelsat phase noise mask for IBS and IDR services by more than 8 dB. This allows phase dependent demodulators to perform better. The close-in phase noise is very low, making the converter ideal for low bit rate digital circuits such as those used in DAMA hub earth stations.

## REMOTE CONTROL

The remote control interface is selectable between EIA-232 and EIA-485. All configuration control, status retrieval, and adjustments are available as simple ASCII commands through the serial interface or through the front panel menu. As a cost option, the remote control command structure can be customized in order to accommodate existing network control software.

## DETACHABLE RF/IF CONNECTOR MODULE

Each UT-4514/X is equipped with a detachable module that establishes input and output connections for the RF and IF paths. The module inserts into a rear compartment of the converter, and requires no additional outside space. The module includes SMA connectors for the RF path and BNC connectors at 50 or 75Ω for the IF path.

## DAISY CHAIN REDUNDANCY SWITCHING

The converter uses CEFD's proprietary "Daisy Chain" integrated switching technology. The Daisy Chain design removes the relays associated with a centralized protection switch tray and distributes them across the individual converters. CEFD was awarded patent 5,666,646 on this distributed protection switch topology.

Daisy Chain technology successfully eliminates a central switching chassis, two power supplies, a microprocessor, and several long, costly cables. Widely accepted in the industry, CEFD's Daisy Chain provides both pricing and marketing advantages.

## MINIMUM RACK SPACE

Due to its small rack height (1.75 inches) and the elimination of the space penalty paid for a separate 1+N switch chassis, the UT-4514/X and the Daisy Chain switch architecture provide the most compact and cost effective converter subsystem available. The units are ideal for the construction of transportable systems such as "flyaways," and high capacity earth stations where space utilization and economy are prime considerations.

# UT-4514/X Ku-Band Up Converter

## Specifications

Frequency Range	
UT-4514	14.00 to 14.50 GHz
UT-4514/C	12.75 to 13.25 GHz
UT-4514/D	13.75 to 14.50 GHz
UT-4514/E	14.70 to 15.00 GHz
UT-4514/F	12.75 to 14.50 GHz
Conversion	Dual, No Inversion
Step Size	125 kHz standard, 1 kHz optional
Preset Channels	32 frequencies and gains
Stability Over Time	$\pm 1 \times 10^{-9}$ /Day
Stability Over Temp	$\pm 1 \times 10^{-8}$ 32 to 122°F (0 to 50°C)
<b>IF Input</b>	
Input Level	-35 dBm Typical
Range	52 to 88 or 104 to 176 MHz Optional 50 to 90 MHz or 100 to 180 MHz (Contact factory with specific requirements)
Return Loss	23 dB Minimum with I/O Module or Switch Module
Impedance	50 or 75Ω
Noise Figure	13 dB Maximum at 0 dB Attenuation
<b>RF Output</b>	
Level	+10 dBm at 1 dB Compression
Range	52 to 88 or 104 to 176 MHz
Non-Carrier Spurious	-80 dBm
Carrier Spurious	-65 dBc at 0 dBm Output
Intermodulation	-38 dBc at 0 dBm Output SCL
AM to PM	0.1°/dB at -5 dBm Out
Return Loss	23 dB Minimum with RF/IF Connector Module or SW Module
Carrier Mute	-70 dBc
<b>Transfer</b>	
Gain	35 dB $\pm$ 2 dB
Attenuation Adjust	0 to 20 in 0.25 dB Steps 0.1 dB Steps Optional
Gain Stability	$\pm$ 0.25 dB/Day
Ripple	$\pm$ 0.25 dB ( $\pm$ 18 MHz) Optional $\pm$ 20 MHz 0.75 dB ( $\pm$ 36 MHz) Optional $\pm$ 40 MHz (Contact factory with specific requirements)
Slope	0.05 dB/MHz
IF Bandwidth	36 or 72 MHz, Optional 40 or 80 MHz (Contact factory with specific requirements)
<b>External Reference</b>	
	Input, either 5 or 10 MHz Option @ +3 dBm Optional 10 MHz Rear Panel Reference Output
<b>Group Delay</b>	
Linear	0.03 ns/MHz
Parabolic	0.01 ns/MHz <sup>2</sup>
Ripple	1.0 ns Peak-to-Peak

Patented  
Daisy Chain  
distributed  
converter protection  
switching



Phase Noise	Limit (dBc/Hz)		Typical (dBc/Hz)	
	UT-4514	UT-4514F	UT-4514	UT-4514F
100 Hz	-72	-66	-79	-69
1 KHz	-79	-76	-82	-79
10 KHz	-89	-86	-92	-89
100 KHz	-98	-96	-101	-99
1 MHz	-110	-106	-114	-109

## Remote Control (Rear Panel)

Comm Port RS-485 or RS-232C

## Indicators (Front Panel)

Power On	Green LED
Mute	Yellow LED
Remote	Yellow LED
Reference	Yellow LED
Stored Fault	Red LED
Fault	Red LED

## Test Points (Front Panel)

RF Sample	SMA, -20 dBc Nominal
IF Sample	BNC, -20 dBc Nominal
Optional L.O. Sample	

## Power

Voltage	90 to 250 VAC Auto ranging, optional -48 VDC
Frequency	47 to 63 Hz
Dissipation	60 Watts

## Environmental

Temperature	32 to 122°F (0 to 50°C)
Altitude	10,000 Feet MSL
Humidity	0 to 95% Relative Humidity

## Physical

Dimensions (1RU)	19W x 1.75H x 22D Inches (48.30W x 4.45H x 55.90D cm)
Weight	15 Pounds (7.0 kg)

## MTBF

49,740 hrs (calculated)  
> 100,000 hrs. (field experience)

## Summary Alarm

Relay Closure | Form C

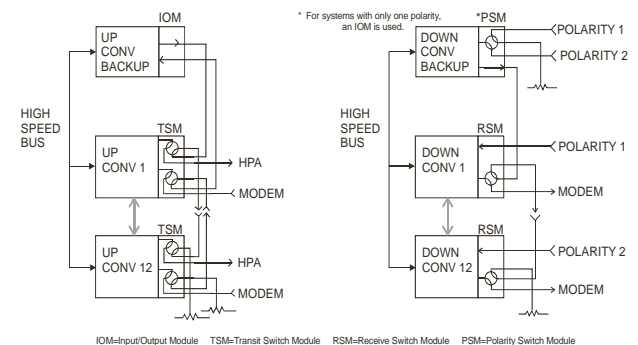

IOM=Input/Output Module TSM=Transit Switch Module RSM=Receive Switch Module PSM=Polarity Switch Module