



ES56-1

5.6 Meter ESA

The Andrew 5.6 Ku- and K-band earth station antennas feature a uniquely formed dual reflector Gregorian system coupled with close-tolerance manufacturing provides maximum durability with minimal maintenance.

The 5.6M Ku- and K-band antenna features a tripod ground mount fabricated from hot-dipped galvanized steel to ensure extended product life.



Features :

- › Deep equipment enclosure for hub mount electronics
- › 3-year warranty on all structural components

Electrical Performance Meets or Exceeds :

- › FCC Regulation 25.209
- › ITU-R, S.580 and S.465
- › Russian Homologation Certificate # OC/1-AO-136

Design Standards

Material/Finish Reflector: Aluminum, conversion coated, painted with highly diffusive white paint

Ground Mount: Hot-dipped galvanized steel, per ASTM-A123 for structural steel

Sizes < 3/8 in (9.5 mm), stainless steel, passivated per MIL-F-14072-E300

Hardware: Sizes > 3/8 in (9.5 mm), hot-dipped galvanized steel per ASTM-A123

Mechanical Specifications

Optics Type: Dual-reflector, Gregorian

Reflector Material: Precision formed aluminum

Reflector Segments: 16

Diameter 52.00" (1.32)

Hub/Enclosure Dimensions: Depth 46.00" (1.17)

Mount Type: Tripod mount

Elevation 5 (85)

Antenna Pointing Range: Azimuth 180 (120)

Course/(Continuous): Polarization 180 (180)

Environmental Conditions

Operating Temperature: -40° to 125°F (-40° to 50°C)

Antenna, with or without motor drives will survive 65 mph (105 km/h) winds

Wind Loading, Survival: while in a stationary position

Antenna with motor drives or fixed antennas can be repositioned in winds of 45

Wind Loading, Operational: mph (72 km/h), with gusts up to 65 mph (105 km/h)

1 G vertical and horizontal acceleration ; equivalent to a Richter magnitude 8.3

Seismic (Earthquakes): and grade 11 on the modified Mercalli scale

Rain: 4 in (102 mm) per hour

Solar Radiation: 360 BTU/hr/ft² (1135 W/m²)

Relative Humidity: 100

Shock and Vibration: As encountered by commercial air, rail and truck shipment

Atmospheric Conditions: As encountered in a moderately corrosive coastal and industrial area

Dimensional Drawings

Tripod mount, Top View:

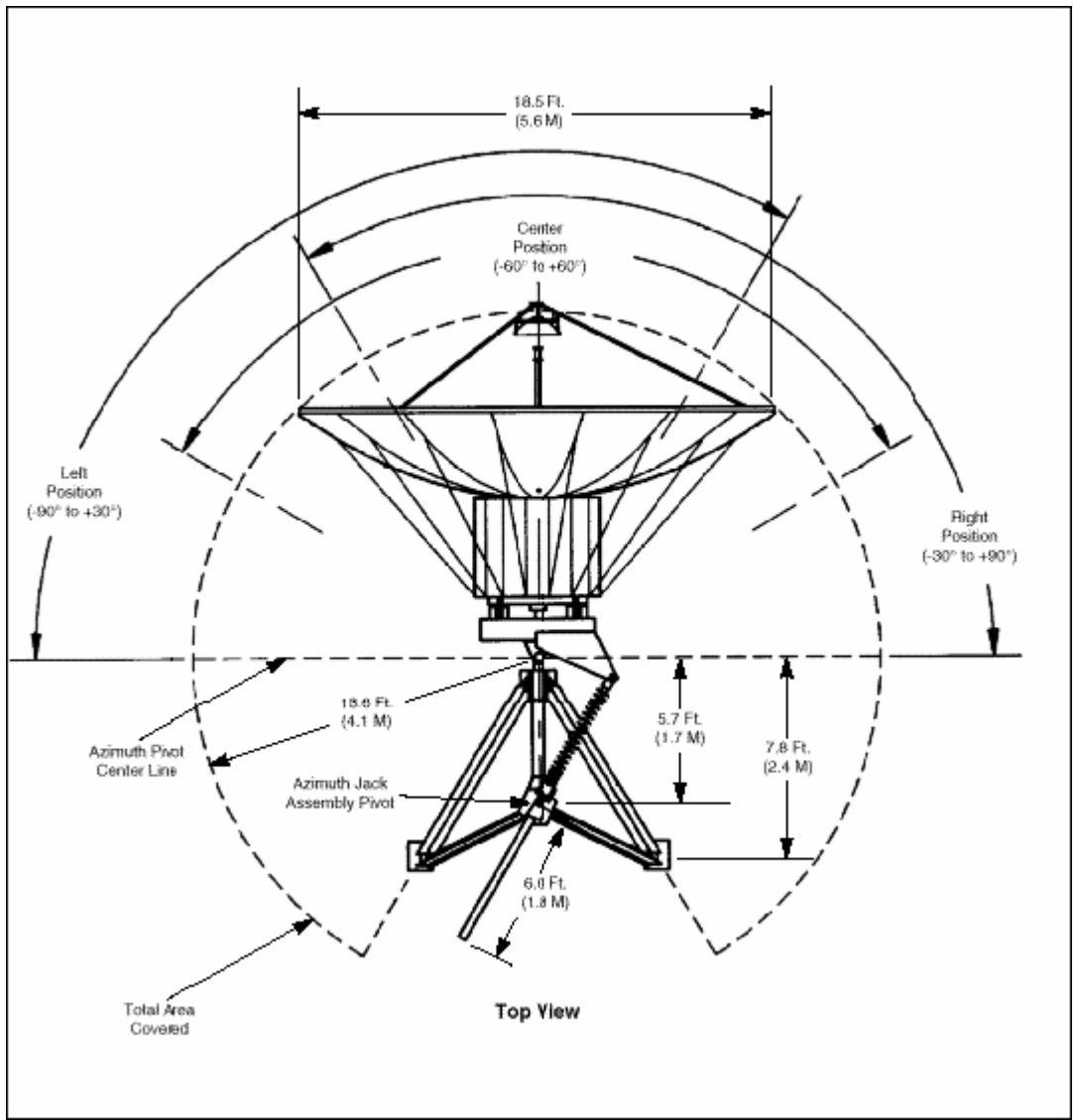

Tripod mount, Side View:

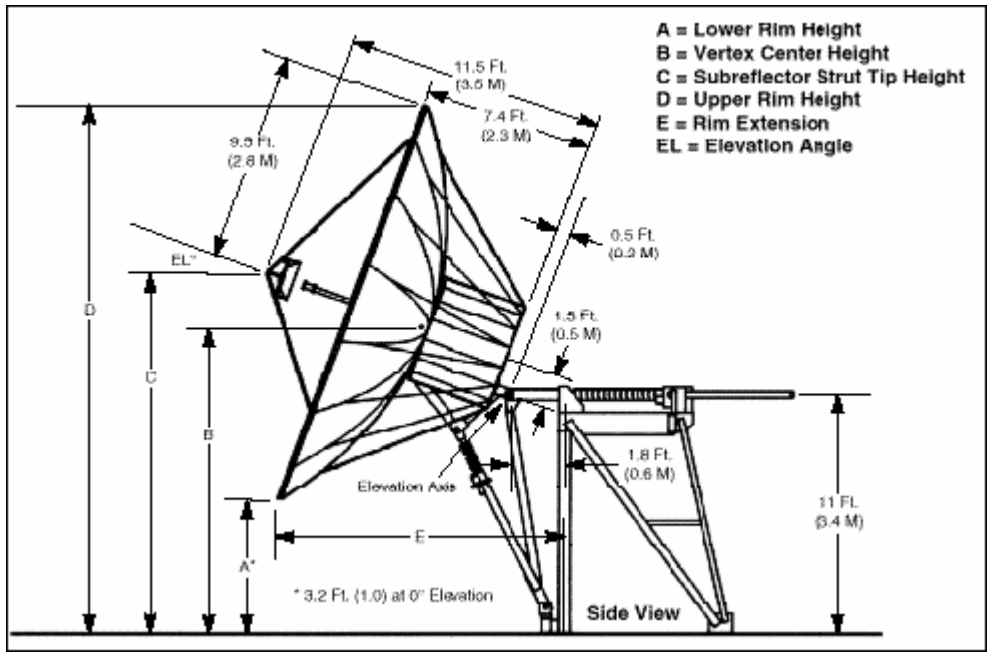

Energy Density Calculation

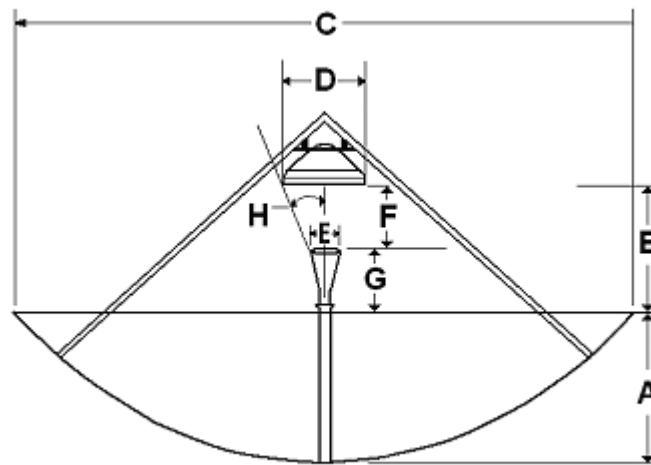

A: Vertex to aperture plane of main reflector	3.3 ft (1.01 m)
B: Aperture plane of main reflector to aperture plane of subreflector	2.8 ft (0.85 m)
C: Diameter of main reflector	18.5 ft (5.6 m)
D: Diameter of subreflector	1.8 ft (0.55 m)
E: Diameter of feed horn (Ku -Band)	0.38 ft (0.12 m)
F: Distance from feed aperture to aperture plane of subreflector (Ku -Band)	1 ft (0.3 m)
G: Distance from aperture plane of main reflector to feed horn aperture (Ku -Band)	1.84 ft (0.56 m)
H: Angle from bore sight to subreflector edge	

Earth Station Antenna and Feed System Specifications

ES56-1	5.6 M Ku - and K-Band Transmit/Receive Earth Station Antenna. Motorizable tripod mount			
Nominal Ku Band G/T Antenna Performance				
LNA/LNB Noise Temperature:	165 K	125 K	90 K	
G/T @ 10 Degrees Elevation:	32.2 dB/K	33 dB/K	34 dB/K	
Beamwidth, midband, degrees	K-Band Rx	K-Band Tx	Ku-Band Rx	Ku-Band Tx
3 dB			0.28°	0.23°
15 dB	0.52°	0.44°		

2 Port K Band Transmit / Receive Feed Systems

Feed Part Numbers	2LPKK-56
Operation	Transmit / Receive
Polarization	Linear
Frequency, GHz	10.700-12.750 Rx 17.300-18.400 Tx
Insertion Loss dB Rx (Tx)	0.03 (0.02)

Port-to-Port Isolation, dB

Tx to Rx	85
----------	----

Interface Flange

Tx Port	WR62
Rx Port	WR75

Gain @ feed output flange (dBi ± 0.2 dB)

Frequency	
10.7000 GHz	54.2
11.9500 GHz	55.2
12.7500 GHz	55.7
17.3000 GHz	57.9
18.4000 GHz	58.4

Antenna Noise Temperature - clear sky conditions, at 68°F (20°C)

10° elevation	69
30° elevation	55
50° elevation	50

Tx Power Capacity	2000 W per port
--------------------------	-----------------

Maximum Pressurization	0.50 psi
-------------------------------	----------

4 Port K Band Transmit / Receive Feed Systems

Feed Part Numbers	4LPKK-56
--------------------------	-----------------

Operation	Transmit / Receive
------------------	--------------------

Polarization	Linear
---------------------	--------

Frequency, GHz	10.700-12.750 Rx 17.300-18.400 Tx
-----------------------	--------------------------------------

Insertion Loss dB Rx (Tx)	0.05 (0.04)
----------------------------------	-------------

Port-to-Port Isolation, dB

Tx to Rx	>35
----------	-----

Interface Flange

Tx Port	WR62G
Rx Port	WR75

Gain @ feed output flange (dBi ± 0.2 dB)

Frequency	
10.7000 GHz	54.0
11.9500 GHz	55.0
12.7500 GHz	55.5
17.3000 GHz	58.0
18.4000 GHz	58.4

Antenna Noise Temperature - clear sky conditions, at 68°F (20°C)

10° elevation	85
30° elevation	71
50° elevation	66

Tx Power Capacity	2000 W per port
--------------------------	-----------------

Maximum Pressurization	0.50 psi
-------------------------------	----------

2 Port Ku Band Transmit / Receive Feed Systems

Feed Part Numbers	2LPKU-56	2LPKUM-56	2LPKUR-56-W
--------------------------	-----------------	------------------	--------------------

Operation	Transmit / Receive	Transmit / Receive	Transmit / Receive
------------------	--------------------	--------------------	--------------------

Polarization	Linear	Linear	Linear
---------------------	--------	--------	--------

Frequency, GHz	10.700-13.250 Rx 13.750-14.800 Tx	10.950-12.750 Rx 14.000-14.250 Tx	10.700-12.750 Rx
-----------------------	--------------------------------------	--------------------------------------	------------------

Insertion Loss dB Rx (Tx)	0.20 (0.10)	0.20 (0.10)	0.10
Port-to-Port Isolation, dB			
Rx to Rx	>35	>35	>30
Tx to Rx	>40	>40	
Interface Flange			
Tx Port	WR75	WR75G	
Rx Port	WR75	WR75G	WR75G
Gain @ feed output flange (dBi ± 0.2 dB)			
Frequency			
10.7000 GHz	54.5		54.5
10.9500 GHz		54.7	
11.9500 GHz	55.5	55.5	55.5
12.7500 GHz		56.1	56.1
13.2500 GHz	56.3		
13.7500 GHz	56.6		
14.0000 GHz		56.8	
14.2500 GHz	57.0	57.0	
14.8000 GHz	57.3		
Antenna Noise Temperature - clear sky conditions, at 68°F (20°C)			
10° elevation	49	49	49
30° elevation	38	38	38
50° elevation	35	35	35
Tx Power Capacity		1000 W per port	
Maximum Pressurization	0.50 psi	0.50 psi	0.50 psi

4 Port Ku Band Transmit / Receive Feed Systems

Feed Part Numbers	4LPKU-56-1	4LPKU-56-2
Operation	Transmit / Receive	Transmit / Receive
Polarization	Linear	Linear
Frequency, GHz	10.700-12.750 Rx 13.750-14.800 Tx	10.700-11.700 Rx 12.750-13.250 Tx 13.750-14.800 Tx
Insertion Loss dB Rx (Tx)	0.30 (0.20)	0.30 (0.20)
Port-to-Port Isolation, dB		
Rx to Rx	>35	>35
Tx to Rx	>85	
Tx to Tx	>40	>40
Interface Flange		
Tx Port	Aluminum, WR75G	Aluminum, WR75G
Rx Port	Aluminum, WR75G	Aluminum, WR75G
Gain @ feed output flange (dBi ± 0.2 dB)		
Frequency		
10.7000 GHz	54.1	54.1
10.9500 GHz		54.3
11.9500 GHz	55.1	
12.7500 GHz	55.6	55.6
13.2500 GHz		55.8
13.7500 GHz	56.3	56.3
14.2500 GHz	56.7	56.7
14.8000 GHz	57.0	57.0

Antenna Noise Temperature - clear sky conditions, at 68°F (20°C)

10° elevation	71	71
30° elevation	60	60
50° elevation	57	57
Tx Power Capacity	2000 W per port	2000 W per port
Maximum Pressurization	0.50 psi	0.50 psi

Typical Antenna Patterns - Ku Band

5.6M Ku-Band Azimuth RCV @

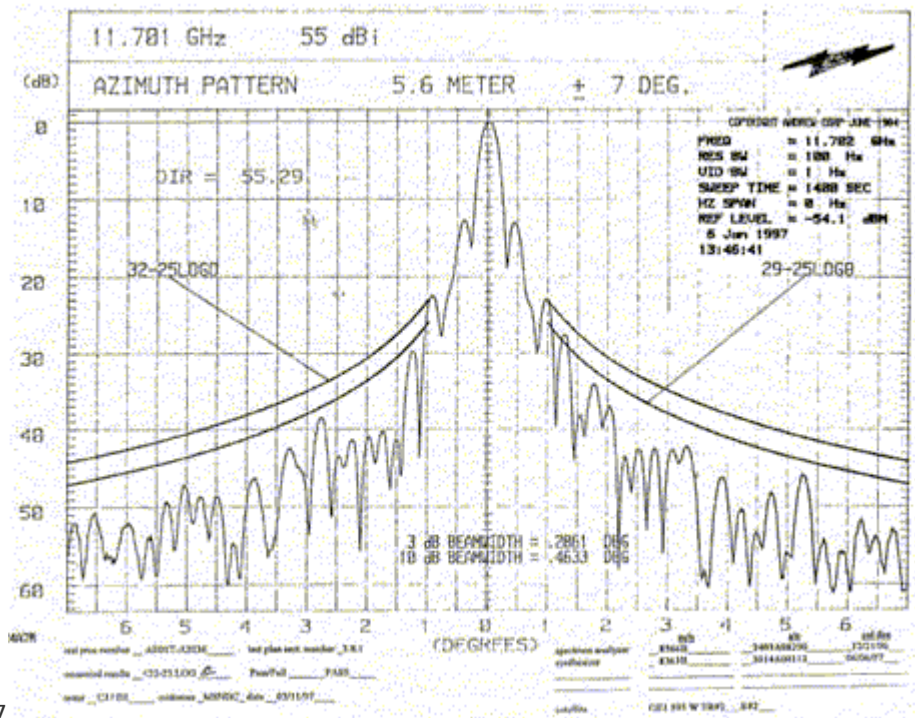

11.7

5.6M Ku-Band Azimuth TX @

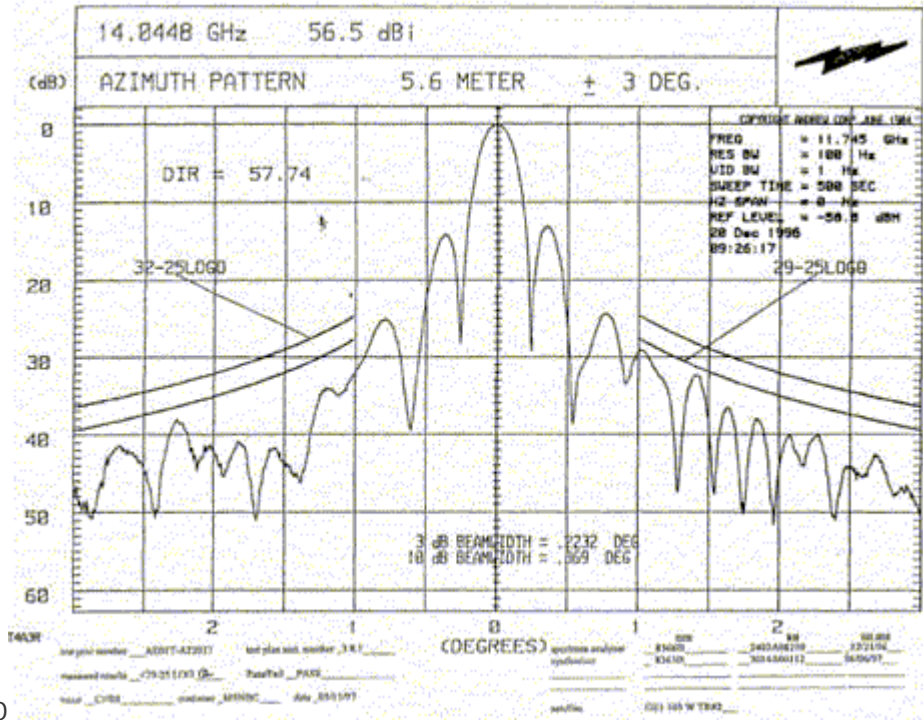

14.0

5.6M Ku- Band Elevation RCV @

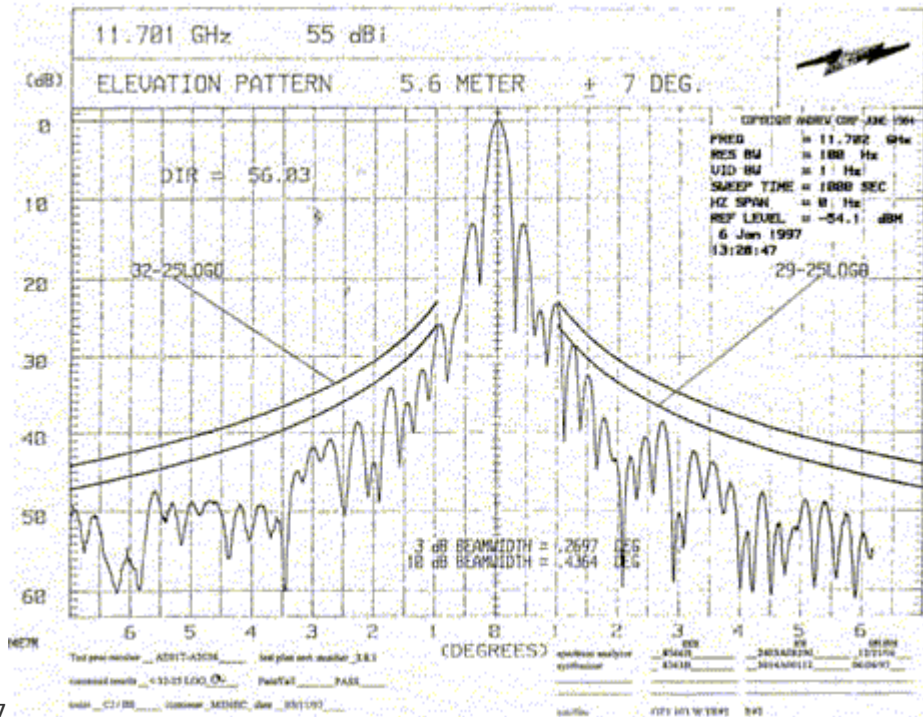

11.7

5.6M Ku- Band Elevation TX @

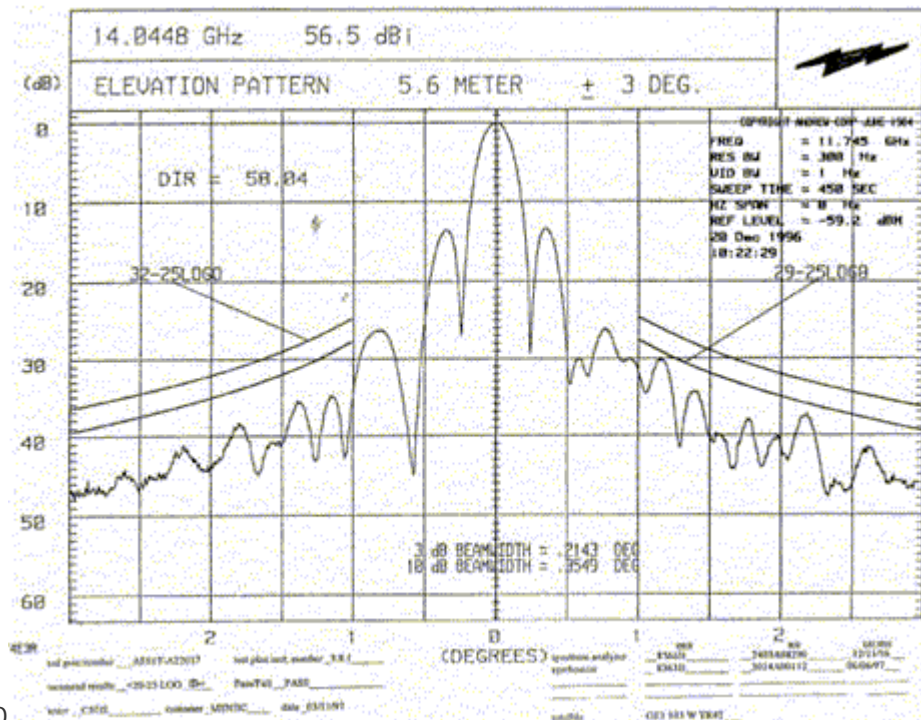

14.0

Motorization and Antenna Controllers

Ku- and K Band:

The MK7VS-xxx variable speed motor kits include 3 HP Azimuth and Elevation motors, line filters and mounting kits. The local motor controller provides electrical power distribution and local control of the motors at the antenna pedestal. The local motor controller is housed in an environmental protected enclosure that mounts to the side of the antenna pedestal.

The hand held controller allows the operator or maintenance personnel to control the position the antenna and the feed polarization from the local motor controller.

The ACS100 automatically moves the antenna to the requested satellite position

A jog switch is provided on the front panel to allow manual movement of the antenna. 40 satellite positions can be entered and stored in the ACS100 memory

The ACS3000S-xx-7-xxx is an all-inclusive motorization and antenna controller package. Includes Outdoor Unit (ODU), Data Transmission Unit (DTU) and jack mounted gear motors. Can be run by customer-provided PC running a Web browser installed on a private local area network, an existing station monitor and control computer via serial interface, or the included Andrew handheld unit. Data transmission unit accepts external tracking signals supplied by either the customer or an optional tracking receiver. In addition to manual control, the ACS3000S-() provides Andrew proprietary SmarTrack® and ephemeris data automated tracking with NORAD two Line or Intelsat® element sets.

Requires customer-provided PC. Beacon receiver (if required), ordered separately.

Typical weights and dimensions for ACS3000S products is: 48 in L x 43 in W x 56 in H, 275 lbs

Part Number	Description	Specifications
-------------	-------------	----------------

MK7VS-208	Variable speed motorization kit. 0.5 deg/sec fast, Az/EI. 0.05 deg/sec slow, Az/EI	Power: 200-230 VAC, 3 phase 50//60 Hz. 4 conductor (3 ph Delta_safety ground. or 5 conductor (3 ph WYE+safety ground.) Use with ACS100-100 controller
MK7VS-380	Variable speed motorization kit. 0.5 deg/sec fast, Az/EI. 0.05 deg/sec slow, Az/EI	Power: 380-460 VAC, 3 phase 50//60 Hz. 4 conductor (3 ph Delta_safety ground. or 5 conductor (3 ph WYE+safety ground.) Use with ACS100-100 controller
ACS100-100	Antenna programmable control system. Incl: positioner, local motor controller, 100 ft control cable	265 VAC 50/60 Hz, 1 Ph. Use with MK(*)VS-(*) variable speed motorization packages.
ACS100-100	Antenna programmable control system. Incl: positioner, local motor controller, 100 ft control cable	265 VAC 50/60 Hz, 1 Ph. Use with MK(*)VS-(*) variable speed motorization packages.
ACS3000S-05-7-208	Antenna control system, StepTrack. Incl: ODU,DTU, jackmount gearmotors, handheld unit. 50m cable	Run by customer-provided PC running a Web browser installed on a private LAN, an existing station M&C computer or the handheld unit. Beacon receiver ordered separately. 0.5 Fast/0.05 Slow Az/EI. 200-230VAC/3Ph/50-60 Hz. 4 cond (3ph Delta+safety gnd) or 5 cond (3ph WYE+ safety gnd)
ACS3000S-05-7-380	Antenna control system, StepTrack. Incl: ODU,DTU, jackmount gearmotors, handheld unit. 50m cable	Run by customer-provided PC running Web browser installed on a private LAN, an existing station M&C computer or the handheld unit. Beacon receiver ordered separately. 0.5 Fast/0.05 Slow Az/EI. 380-460 VAC/3Ph/50-60 Hz. 4 cond(3ph Delta+safety gnd) or 5 cond(3ph WYE+ safety gnd)
ACS3000S-10-7-208	Antenna control system, StepTrack. Incl: ODU,DTU, jackmount gearmotors, handheld unit. 100m cable	Run by customer-provided PC running a Web browser installed on a private LAN, an existing station M&C computer or the handheld unit. Beacon receiver ordered separately. 0.5 Fast/0.05 Slow Az/EI. 200-230VAC/3Ph/50-60 Hz. 4 cond (3ph Delta+safety gnd) or 5 cond (3ph WYE+ safety gnd)
ACS3000S-10-7-380	Antenna control system, StepTrack. Incl: ODU,DTU, jackmount gearmotors, handheld unit. 100m cable	Run by customer-provided PC running a Web browser installed on a private local area network, an existing station monitor and control computer or the handheld unit. 100 m cabling Motor Speed: 0.5 fast/slow, Az and EI Power: 380-460 VAC, 3 Ph, 50/60 hZ 4
ACS3000S-F2-7-208	Antenna control system, StepTrack. Incl: ODU,DTU, jackmount gearmotors, handheld unit. 200m fiber	Run by customer-provided PC running a Web browser installed on a private LAN, an existing station M&C computer or the handheld unit. Beacon receiver ordered separately. 0.5 Fast/0.05 Slow Az/EI. 200-230VAC/3Ph/50-60 Hz. 4 cond (3ph Delta+safety gnd) or 5 cond (3ph WYE+ safety gnd)
ACS3000S-F2-7-380	Antenna control system, StepTrack. Incl: ODU,DTU, jackmount gearmotors, handheld unit. 200m fiber	Run by customer-provided PC running Web browser installed on a private LAN, an existing station M&C computer or the handheld unit. Beacon receiver ordered separately. 0.5 Fast/0.05 Slow Az/EI. 380-460 VAC/3Ph/50-60 Hz. 4 cond(3ph Delta+safety gnd) or 5 cond(3ph WYE+ safety gnd)

Polarization Drive Kit

Ku and K-Band:

A motorized feed polarization kit automatically switches the feed polarization in the field. The PK5DRA prime focus polarization drive kit can be mounted to the 7.3-meter antenna linearly polarized feed to provide feed rotation to switch from linear or horizontal polarization

Part Number	Description	Specifications
PK5DRA	Polarization Drive Kit	Nominal Speed 1.3 Degrees/Second @ 50 Hz 1.5 Degrees/Second @ 60 Hz

Cross and Polarization Axis Waveguide Kits

XAPKK-76	K-Band cross and polarization axis w/g kit. 1 run Tx.
XAPKK-76-UPG	K-Band cross and polarization axis w/g kit. 2nd run transmit. Order with XAPKK-76
XAPKU-76	Ku-band cross and polarization axis w/g kit. 1 run transmit.
XAPKU-76-UPG	Ku-band cross and polarization axis w/g kit. 2nd run transmit. Order with XAPKU-76

Heating Options

Ku and K-Band:

Antenna de-icing is forced heated air. A sensor and controller unit automatically senses moisture and activates the system whenever the need for heating is determined.

Full reflector electric de-icing. Incl remote panel, controller and 100 ft cabling	WEC56R-208-100
Feed heater kit Ku and K-band.	FH5A
Full reflector and feed electric de-icing. Incl remote panel, controller and 100 ft cabling	WEC56RF-208-100
Full reflector electric de-icing. Incl remote panel, controller and 100 ft cabling	WEC56R-380-100
Full reflector and feed electric de-icing. Incl remote panel, controller and 100 ft cabling	WEC56RF-380-100

Options

Contact Sales for part number and pricing for your specific requirement.

Lubrication and Maintenance Kit	209906-2
Hub Heater Kit	HUBHTR-230 Antenna Hub Heater Provides Approx 3000 W/Heat C
Emergency Hub Light Kit	EMRGYLT-115 Emergency lighting, hub mounted
Emergency Hub Light Kit	EMRGYLT-230 Emergency lighting, hub mounted
Hub Light Kit	HUBLT-115
Foundation Grounding Kit	ANTGND-9 Antenna foundation grounding kit.t.
Hub Light Kit	HUBLT-230 Hub Light Kit, 230 VAC. Supplied w/ 100 W bulb.
Lightning Rod Kit	LRK9 Lightning rod kit
Obstacle Warning Light Kit	OBWRNLT-115 Operates at 108-132V, 1 Phase, 50-60 Hz
Obstacle Warning Light Kit	OBWRNLT-230 Obstruction Warning Light Kit. Operates at 216-26
Miscellaneous	TK-MAN-LG Tool Kit, Manual Antennas. Hand tools with tool b
Miscellaneous	TK-MOT-LG Tool Kit, Motorized Antenna. Hand tools with tool
Rain Deviator Kit	RD5 Rain Deviator Kit
Maintenance Ladder and Platform Kit	MANPL7 maintenance ladder and Platform Kit. Azimuth rang

Typical Slab and Pier Foundation Specifications

Soil Bearing Capacity	2000 lb/ft ² (9764 kg/m ²)
Reinforcing Steel	1308 lb (593 kg)
Concrete Compressive Strength	3000 lb/in ² (211 kg/cm ²)
Foundation Length	14 ft (4.5 m)
Foundation Width	14 ft (4.5 m)
Foundation Depth	1.5 ft (0.5 m)
Foundation Concrete Volume	12.1 yd ³ (9.3 m ³)
Foundation Specification Drawing	237029
Typical Pier Foundation Drawing	201708A
Typical Slab Foundation Drawing	201620A

Note: Foundation specifications provided are for a typical design only. Certification of suitability for a particular installation by a professional engineer is required prior to it's use for actual fabrication.

Shipping Information

Typical Net Weight	5035 lb (1785 kg)
Typical Shipping Weight	5600 lb (2540 kg)
Typical Shipping Volume	690 ft ³ (19.5 m ³)
Shipping Container	Qty 1 per standard 20 ft land/sea container. Qty 2 per standard 40 ft land/sea container.

Note: Weights and dimensions may vary based upon actual equipment ordered and consolidation of parts. This information should be considered typical for antenna only.

Part numbers, designs and specifications provided are subject to change without notice.
