

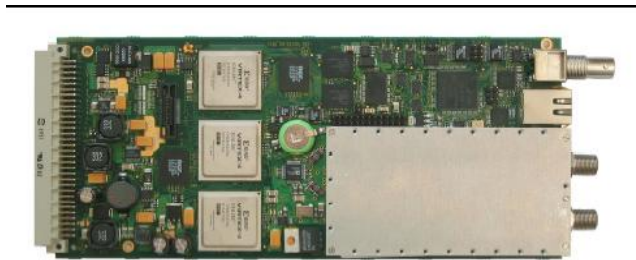

Introduction

Advantech Wireless' SBD75e DVB-S/S2 Broadcast Receiver is designed for the reception and forwarding of digital television signals and/or transmission of high-speed data (IP) over industry standard Digital Video Broadcasting over Satellite (DVB-S/S2).

At the heart of the SBD75e is the Satellite Broadcast receiver (SBR75) which is a low-profile embedded card in a compact form.



For all broadcast applications, this fully featured Demodulator offers unrivaled flexibility supporting DVB-S2 LDPC + BCH coding, SHORT and NORMAL FEC frame, and up to 45 Msymbols.

This card can also be specified with DVB-S and DVB-DSNG Pragmatic Trellis decoding plus Viterbi and Reed Solomon coding allowing the demodulation of existing QPSK, 8PSK and 16QAM DVB-S and DVB-DSNG signals.

When used in DVB-S2 mode, the card offers performance gains of up to 2.5dB compared to older DVB-S systems. This translates approximately to a 30% performance increase in a given transponder bandwidth. This performance gain can be used to increase the data throughput in a given transponder bandwidth, provide more link margin or even to reduce antenna size.

New DVB-S2 modes of operation, such as Constant Coding and Modulation (CCM), Variable Coding Modulation (VCM) and Adaptive Coding and Modulation (ACM), further improve available throughput on given satellite channels.

The performance benefits, reliability and interoperability of standards-based DVB-S2 makes it the ideal solution for broadcasters considering implementing new services or upgrades from current DVB-S networks.

All operation modes (CCM, VCM, ACM) can operate in either Single Stream mode or Multi Stream mode. The Multi Stream mode provides the capability to combine several Transport Streams into one carrier in a fully transparent way and fully independent from each other. Hence, an even more efficient use of the satellite is achieved, while limiting the number of equipment for both the uplink and downlink.

Natively, the SBR75/SBD75e supports up to 4 distinct and fully transparent DVB ASI ports, providing the means to de-aggregate (ISI- filtering) and remap DVB MPEG Transport streams (TS) to individual ASI ports from a single carrier. It may also duplicate a single MPEG TS so that the output appears at both ASI outputs.

Additionally, an optional 10/100/1000BaseT interface is available providing the means to simultaneously support both ASI and Ethernet-based data and video streams.

On top of this, this unit is also fully compatible with the existing proprietary PTSD mode (Pseudo Transport Stream Demultiplexer) used in some countries. (DVB-S and S-2)

The SBD75e chassis can support up to 3 SBR75 boards in distinct and/or redundant formation within a 1RU chassis, thus providing a compact solution for multi-receiver applications.

Application

The SBR75/SBD75 is designed to provide best in class performance for critical applications such as:

- Digital Video Broadcast (DVB)
- Digital Satellite News Gathering (DSNG)
- Business enterprise data distribution (high speed IP delivery, e-learning, streaming video and audio)
- Multi-Mux reception for cable headends
- Multi-TS contribution networks
- Primary Distribution of Digital Terrestrial Transmission (DVB-T, DVB-H, ATSC, ISDB-T/ SBTVD-T, DMB-T/H)
- Digital Cinema HD content distribution.
- Proprietary deconcentration mode (PTSD) used for DVB-T by some customers (Predecessor of DVB-S2/MS mode).
- Distribution of Digital Handheld Transmission

Broadcast DVB-S2 Demodulator SBD 75e

Performance Specifications

Data and code rates			
DVB-S coding: BPSK: 16kbps to 36Mbps QPSK: 16kbps to 70Mbps			
DVB-DSNG coding: QPSK: 64kbps to 70Mbps OQPSK: 64kbps to 72Mbps 8PSK: 128kbps to 110Mbps 16QAM: 128kbps to 120Mbps			
DVB-S2 short and normal FEC block coding: QPSK: 64kbps to 80Mbps 8PSK: 256kbps to 120Mbps 16APSK: 340kbps to 160Mbps 32APSK: 470kbps to 200Mbps SHORT Block 16kbit 1/4*, 1/3*, 2/5*, 1/2*, 3/5, 2/3, 4/5, 5/6, 7/8, 8/9 NORMAL Block 64kbit 1/4*, 1/3*, 2/5*, 1/2*, 3/5, 2/3, 4/5, 5/6, 7/8, 8/9, 9/10 * Only available in QPSK according to DVB-S2 Specification			
Roll off: 0.15, 0.20, 0.25, 0.30, 0.35			
IF Input Connector: Type F (f) 75 Ohm for L-band Option: BNC (f) for 70/140Mhz. 50 Ohm Return loss: 10 dB LNB Alarm for Short Circuit			
RF Input Frequency: L-band: 950 to 2150Mhz in 1Hz steps Optional: 70+/-18Mhz and L-band 140+/-36Mhz and L-band			
RF Input Power Levels: Nominal: -65 dBm - 10log(400/R) dBm, where R= Symbol Rate in kSymbols AGC range: +/-20dB minimum Max level: 0dBm			
Noise Figure: 9 dB typical, 12 dB at max AGC gain			
LNB Power and Control: Selectable LNB Supply Voltage: ON/OFF, 18 VDC (Horizontal Pol.) or 13 VDC (Vert Pol.) LNB Control: 22 +4kHz single tone burst, amplitude=0.6 +0.2 V p-p			
Typical Eb/No Performance (margin with regards to DVB ideal requirements):			
	DVB-S	DVB-DSNG	DVB-S2
QPSK	<0.5dB	<0.5dB	<0.5dB
8PSK		<0.7dB	<0.7dB
16APSK			<1.0dB
32APSK			<1.5dB
Data Interfaces			
ASI interfaces: Encoded Line Rate: 270 Mbps+100 ppm Sensitivity (D21.5 idle pattern): 200 mV Max. Input Voltage: 880 mV p-p Min. Connector Return Loss: 15 dB Max. Distance: 150 Meters			
Media gateway: Dual ASI in Dual ASI out Dual 10/100 Base-T Ethernet			

Other features

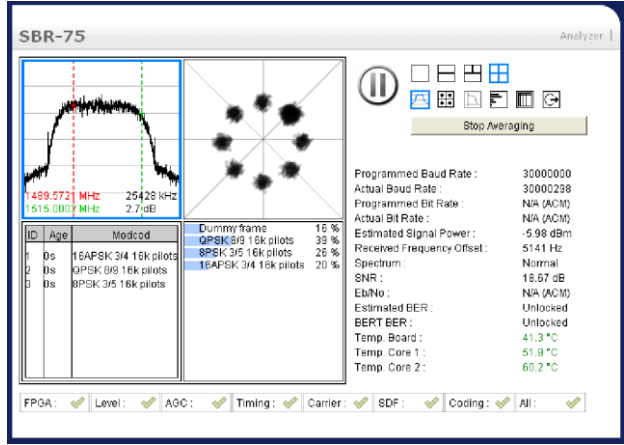
- Integrated Spectrum Analyzer with constellation
- 
- Management via 10/100Base-T with SNMP V3, GUI (RJ-45) or RS-232/RS485 (DB-9).
 - Dual dry alarm contact relays (Interface and System alarms)
 - ISI broadband de-aggregator (selectively retrieves Multiple Transport Streams from carrier).
 - Supports PTSD proprietary deconcentration mode
 - ISSY time stamping for stream synchronization, or
 - Non-ISSY time stamp synchronization
 - Null-packet reinsertion
 - Optional: BISS encryption support
 - Optional: Physical Layer Scrambling
 - Optional: Variable Coding Modulation (VCM)
 - Optional: Adaptive Coding Modulation (ACM)
 - Optional: L-band and 70/140Mhz input support
 - Optional: Multi-receiver (up to 3x SBR75 boards), giving 12 fully independent TS

Physical and Power Specifications

Dimensions: 1RU standalone chassis, 19W X 15.75D X 1.75H inches (48W X 40D X 4.4H cms)
Weight: 8lbs (3.7kgs)
Power: 90 – 264VAC (50/60Hz) or -48VDC (32 to 72VDC).
Power consumption: 50Watts
Operating temp: 0°C to 45°C(32°F to 122°F)
Storage temp: -25°C to 85°C(-13°F to 185°F)
Relative humidity: Operating: Up to 90% non-condensing Non-Operating: Up to 95% non-condensing
Altitude: Operating: up to 10,000' (3,045M) During Transit: up to 40,000' (12,180M)

NORTH AMERICA
USA
Tel: +1 703 788-6882
Fax: +1 703 788-6511
info.usa@advantechwireless.com

CANADA
Tel: +1 514 420-0045
Fax: +1 514 420-0073
info.canada@advantechwireless.com

EUROPE
UNITED KINGDOM
Tel: +44 1480 357 600
Fax: +44 1480 357 601
info.uk@advantechwireless.com

RUSSIA & CIS
Tel: +7 495 967 1859
Fax: +7 495 967 30 24
info.russia@advantechwireless.com

SOUTH AMERICA
BRAZIL
Tel: +55 11 3054 5701
Fax: +55 11 5041 4026
info.brazil@advantechwireless.com

An ISO 9001 : 2008 Company



Ref.: PB-SBD75e-001-11025